

Belle II CDC

Central Drift Chamber

Shoji Uno (KEK IPNS)

STCF2024

2024.01.16

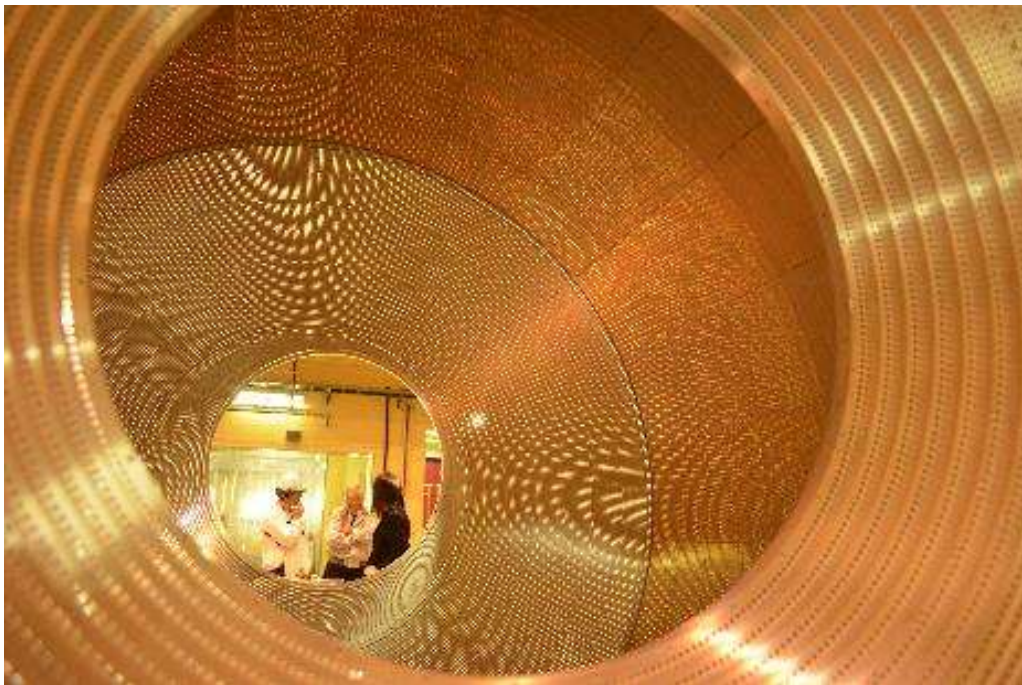

Main Features of Belle CDC

- **The volume should be fitted between vertex detector and particle ID devices.**
- The conical endplates were machined to meet final focusing magnets.
- **A small cell chamber was constructed separately and was installed without any walls between the main part.**
- Electronics boards are located at only backward end plate.
- 3D charged trigger scheme is adopted (Belle II).

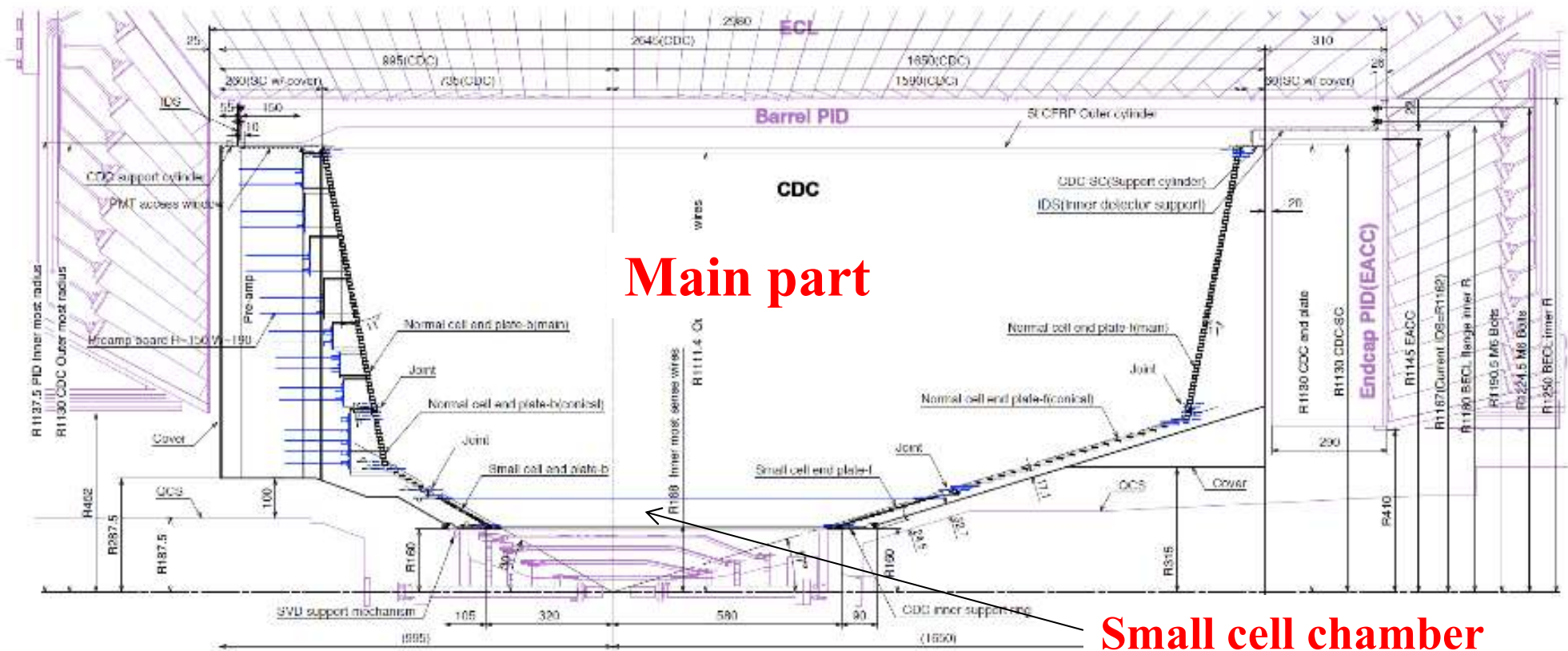

Functions of CDC

- To reconstruct charged tracks
 - Measurement of track momentum precisely under magnetic field
 - Position resolution : $\sim 0.1\text{mm}$
- To obtain information about particle identification
 - Measurement of energy loss in the gas volume
- To provide the trigger signal (L1)
 - Multi small cell type for both CDCs
 - Shorter maximum drift time
 - Simple trigger logic
 - Not TPC and not Jet cell type
 - Two track separation is not essential for the B factory.

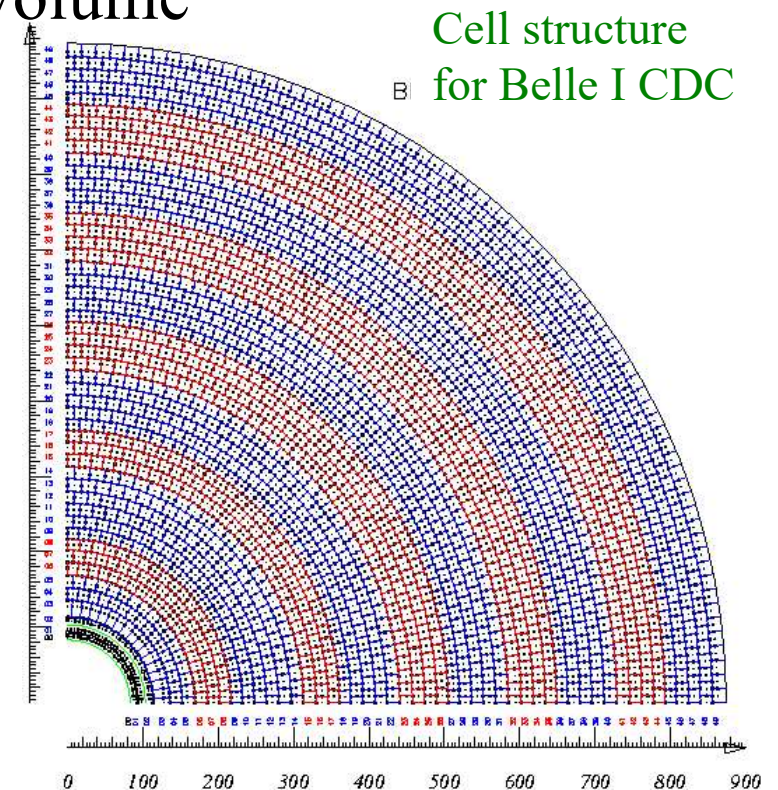

BELLE

Exp 5 Run 272 Farm 5 Event 10889
Eher 8.00 Eler 3.50 Tue Nov 16 23z12z08 1999
TrgID 0 DetVer 0 MagID 0 BField 1.50 DspVer 5.10
Ptot(ch) 11.0 Etot(gm) 0.2 SVD-M 0 CDC-M 0 KLM-M 0

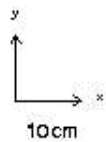
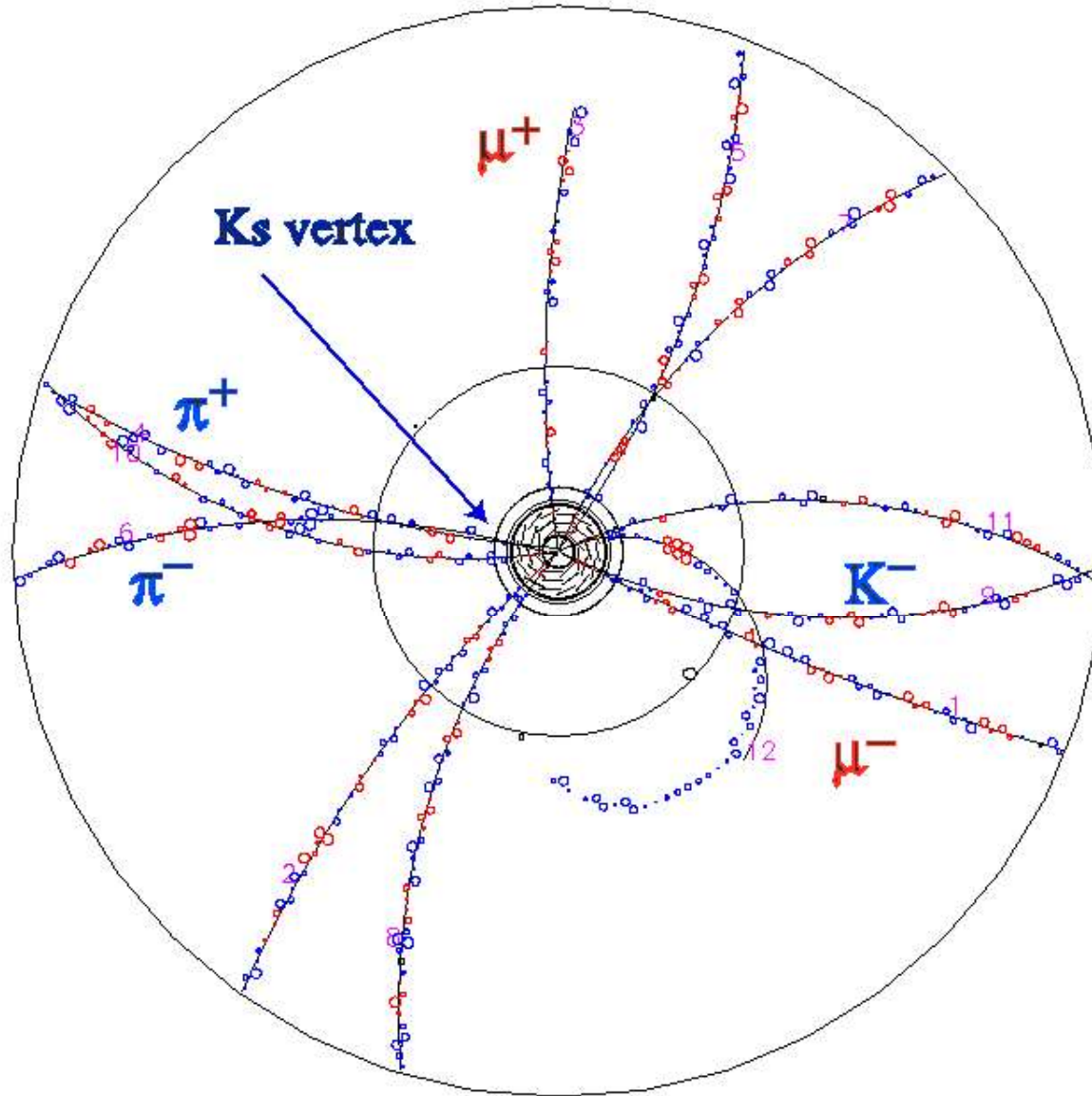

Accuracy on momentum measurement

$$\left(\frac{\sigma_{Pt}}{Pt} \right)^2 = (aPt)^2 + b^2$$

$$a = \frac{\sigma_{r\phi}}{0.3BL^2} \sqrt{\frac{720}{N+5}} \quad b = \frac{0.054}{LB} \sqrt{\frac{L}{X_0}} \left[1 + 0.038 \ln \frac{L}{X_0} \right]$$

B : Magnetic field strength (Tesla)

L : Measurement lever arm (m) (Size of chamber)

$\sigma_{r\phi}$: Measurement error for each point (m)

N : Number of measurement points

X_0 : Radiation length in gas volume (m) (material)

Pt : Transverse momentum (GeV/c)

The parameter (a) is important in higher energy experiment.

The parameter (b) is crucial in relatively lower energy experiment.

Pt distribution in B factory

- Pt for most of decay particles in the B factory is less than 1 GeV.
- Less material is a key to get better momentum resolution.

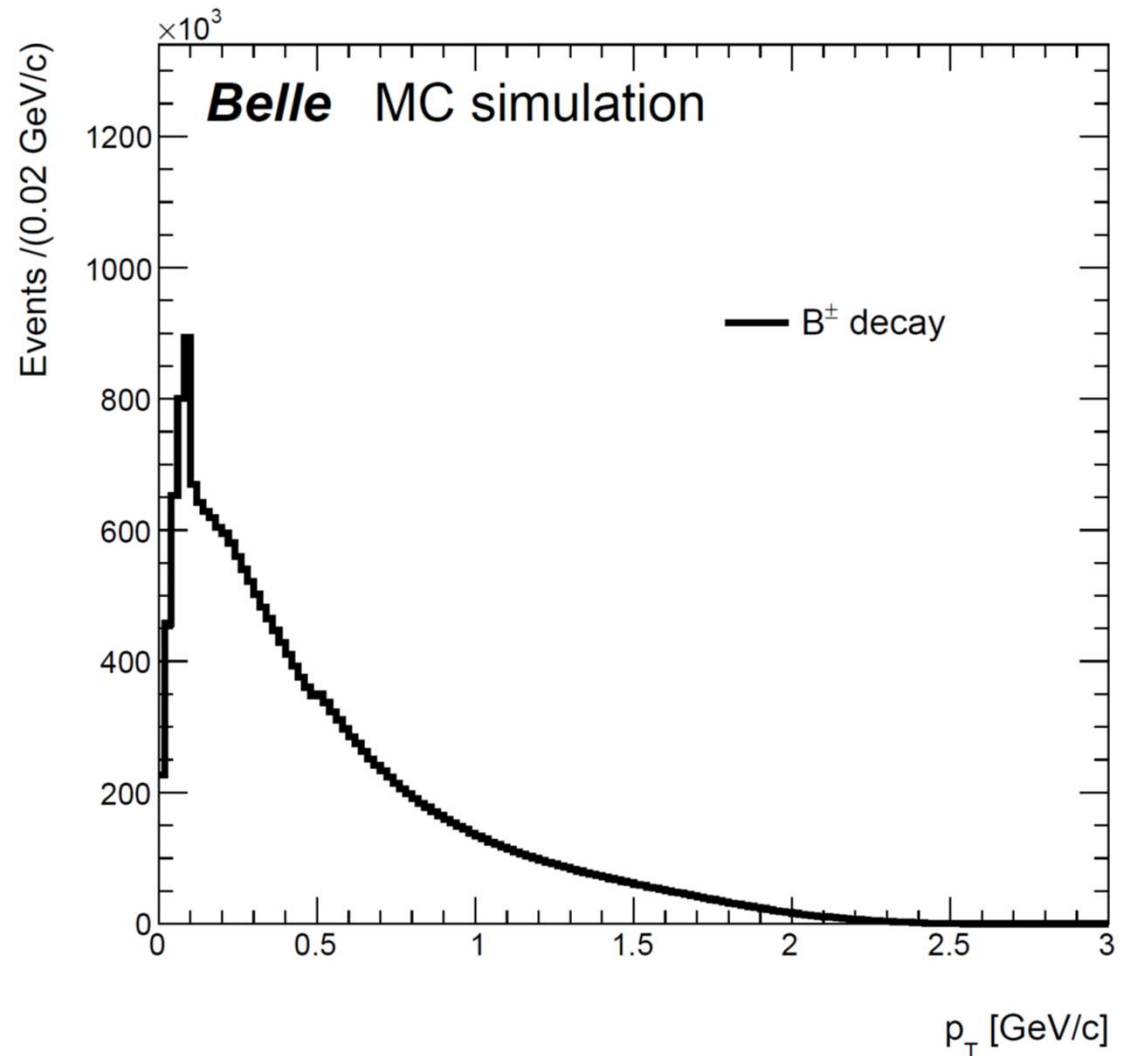

Chamber Gas

- He(50%)-C₂H₆(50%)
for both CDCs
 - Longer radiation length(680m).
 - 0.139% X0 in total gas volume
 - **Drift velocity is higher than other He-based gas.**
 - Average drift velocity :
 - ~3.3cm/μsec in the chamber cell.
 - Maximum drift time :
 - ~400nsec for 18mm cell size.
 - Good dE/dx resolution.

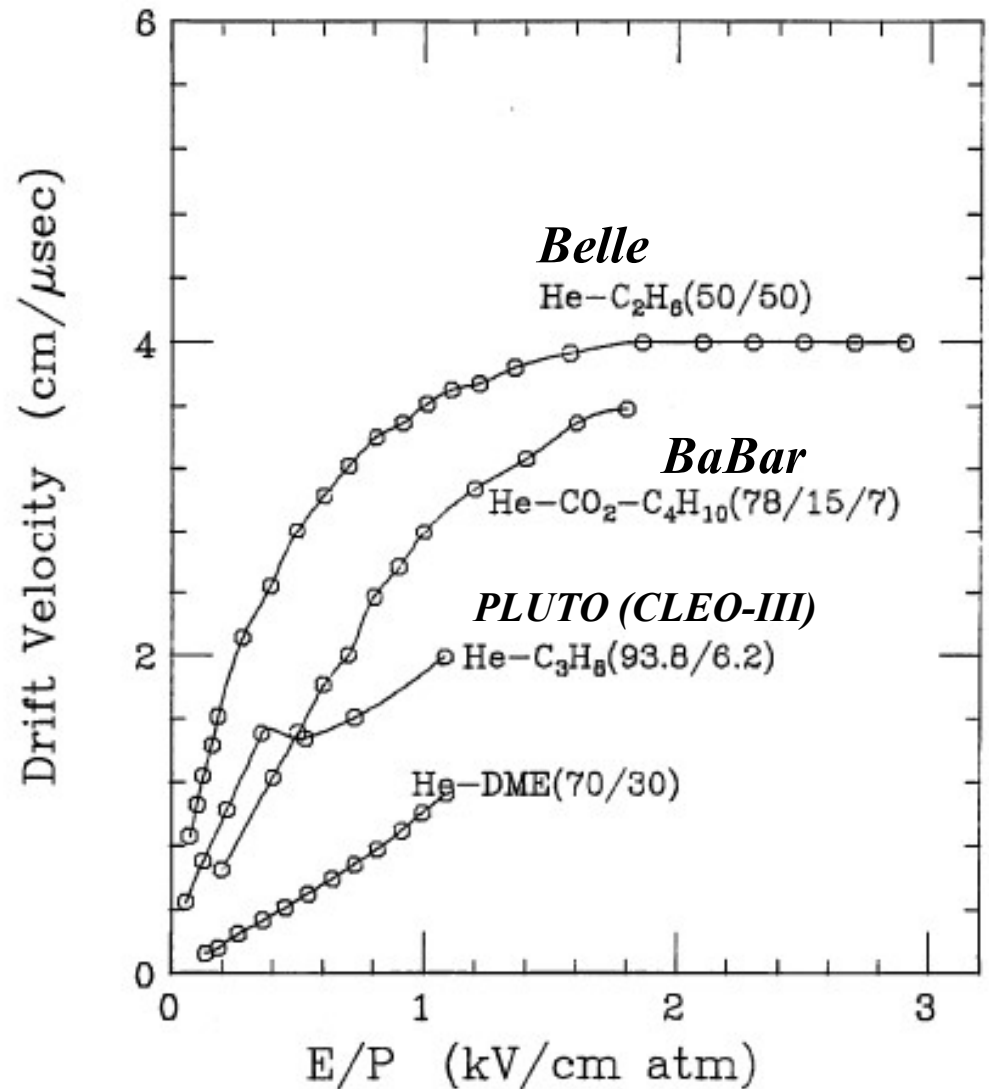

X-T Curve

- He(50%)-C₂H₆(50%)
- B=1.5Tesla
- HV : 2.3KV
- Cell Size:18mm
- Maximum Drift Time :
~400nsec

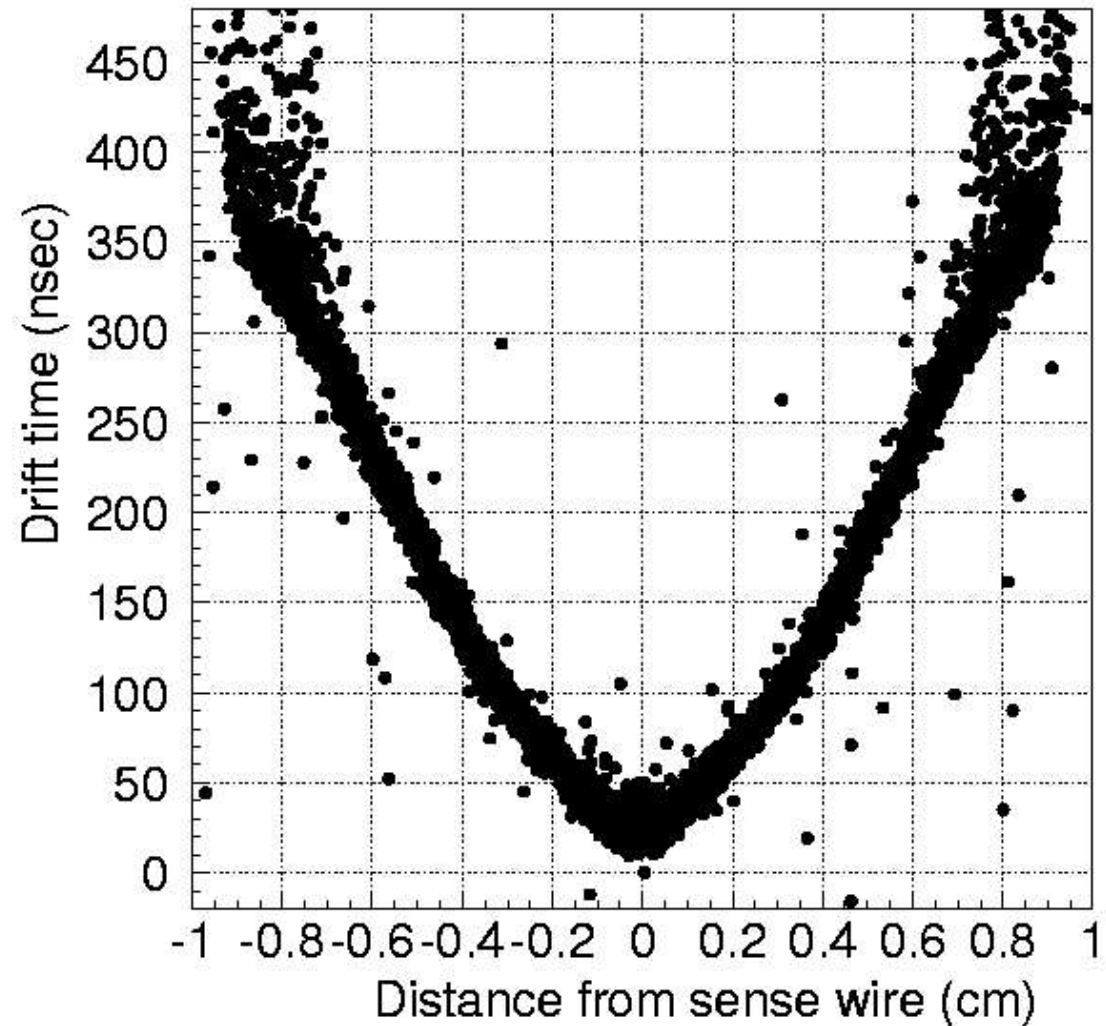

dE/dx Resolution

- The pulse heights for electron tracks from ^{90}Sr were measured for various gases.
- The resolutions for CH_4 and $\text{He}(50\%)\text{-C}_2\text{H}_6(50\%)$ are same.
- The resolution for He-CF_4 is worse than Ar -based gas(P-10).

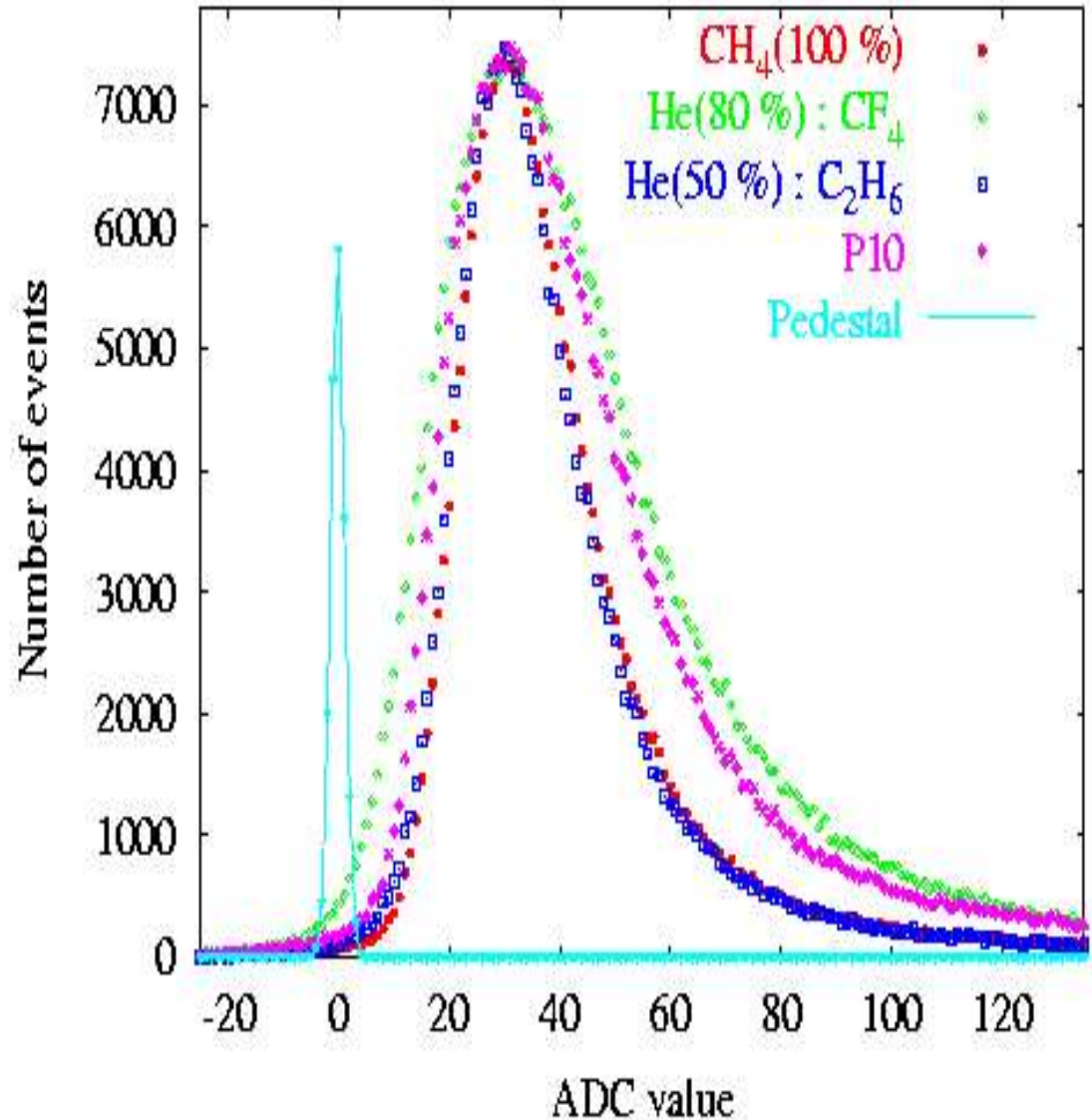

Selection of wires I

- Thicker diameter is better as following reasons.
 - Sense wire : Stronger drift field
 - Drift velocity tends to saturate
 - Diffusion constant smaller
 - Lorentz angle smaller
 - Field wire : Maximum electric field on the surface should be less than 20 kV/cm to avoid radiation damage (Malter effect).



- $\sim 30 \mu\text{m}$ for sense wire
- $\sim 100 \mu\text{m}$ for field wire

Selection of wires II

- Material of wires
 - Sense wire
 - does not affect on total material so much.
 - Au-W (which is used in the world, generally)
 - $30\mu\text{m}^\phi : 0.072\% X_0 < \text{Al field wire}$
 - Field wire
 - Cu-Be : too heavy
 - Al : Worry about creep \rightarrow test \rightarrow OK
 - $126\mu\text{m}^\phi : 0.147\% X_0 \sim \text{Chamber Gas (He(50\%)-C}_2\text{H}_6(50\%))$
 - C : Diameter is not suitable.
 - Be : too difficult to string wire and expensive

Structure of CDC

- How to support huge total wire tension (more 3 tons)?
 - How to string many wires?
 - How much material is allowed for inner cylinder?
 - What value is used for operation gas pressure?
 - Absolute pressure or relative pressure?
- ↓
- Outer cylinder should support whole wire tension.
 - Curved aluminum endplate (thinner endplate with 10 mm thickness)
 - Pre-stress technique
 - One piece of outer CFRP cylinder with 5 mm thickness
 - Thin aluminum sheet (0.1mm thickness) is attached for the electric shield.
 - Thickness of inner cylinder should be minimized and it can be installed after wire stringing for main part.
 - CFRP (+ aluminum) with 0.5 (+0.1) mm thickness

Wire configuration

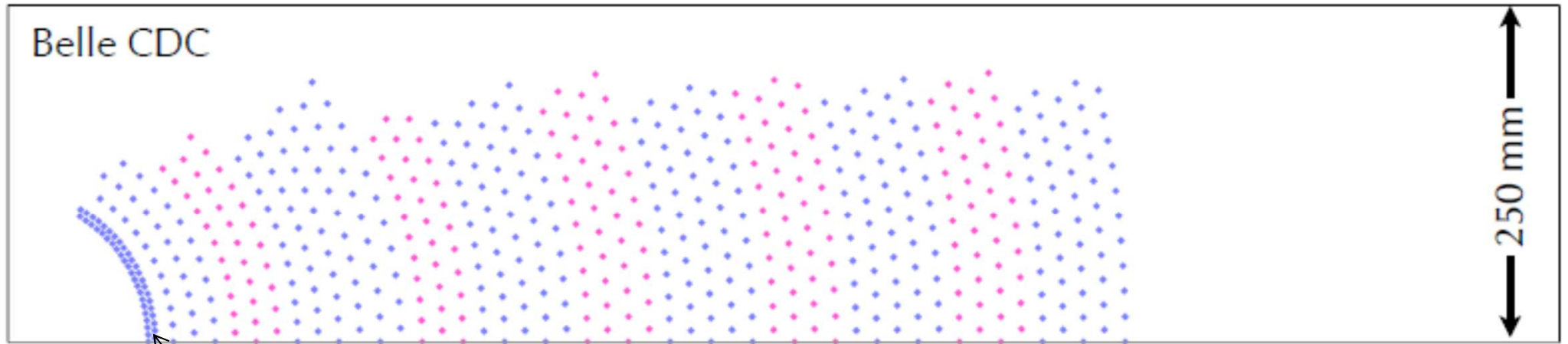

Small cell chamber

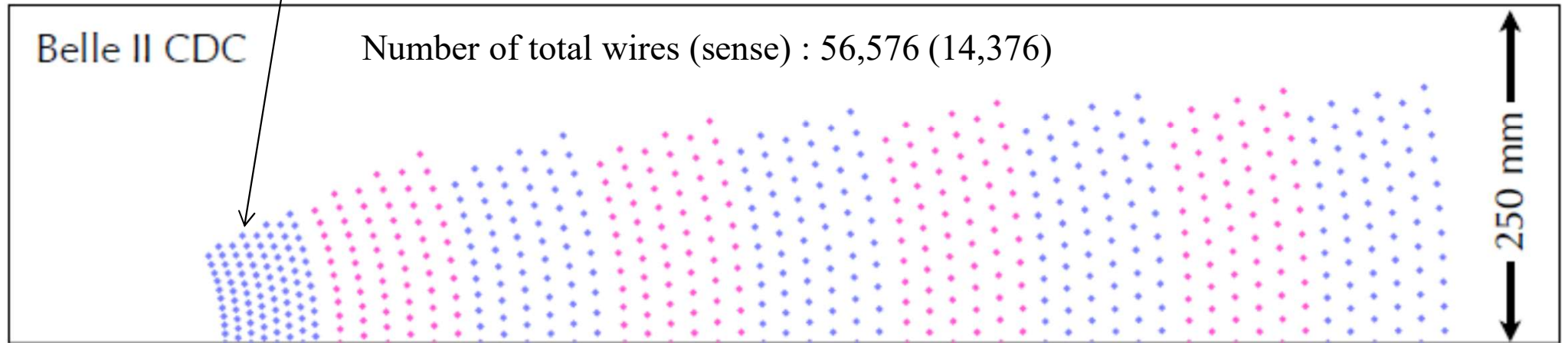

A U A V A U A V A

9 super-layers : 5 axial + 4 stereo(2U+2V) 56 layers in total

Wire stringing for main part



Vertical stringing



One person could access inside to string wires.

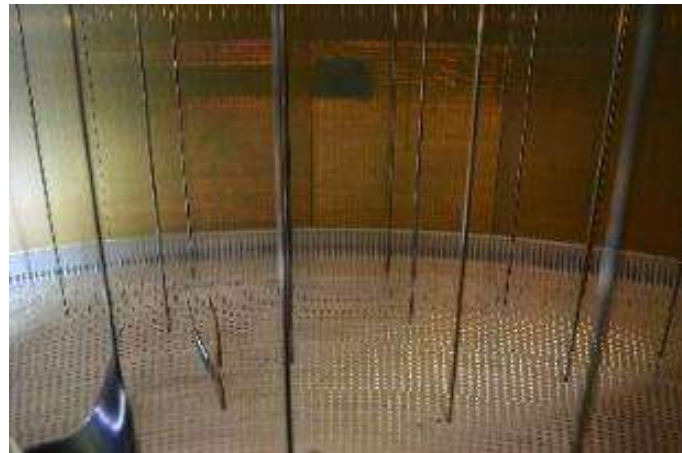

One person could handle wires inside chamber.

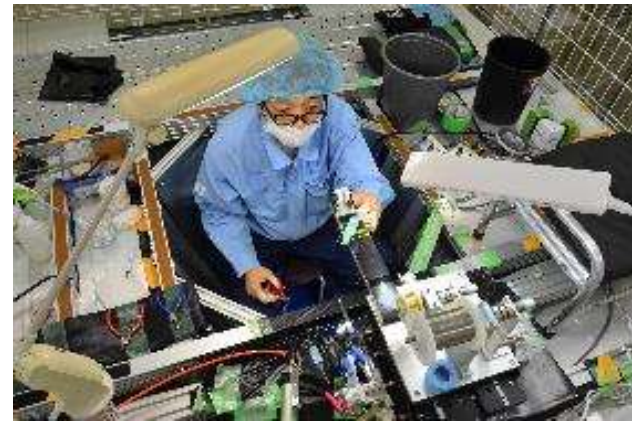

One person could sit with hanging device without touching the endplate to string wires for the conical part.

Wire stringing for small cell chamber



Horizontal stringing
Whole wire tension is supported
with thin inner CFRP cylinder.

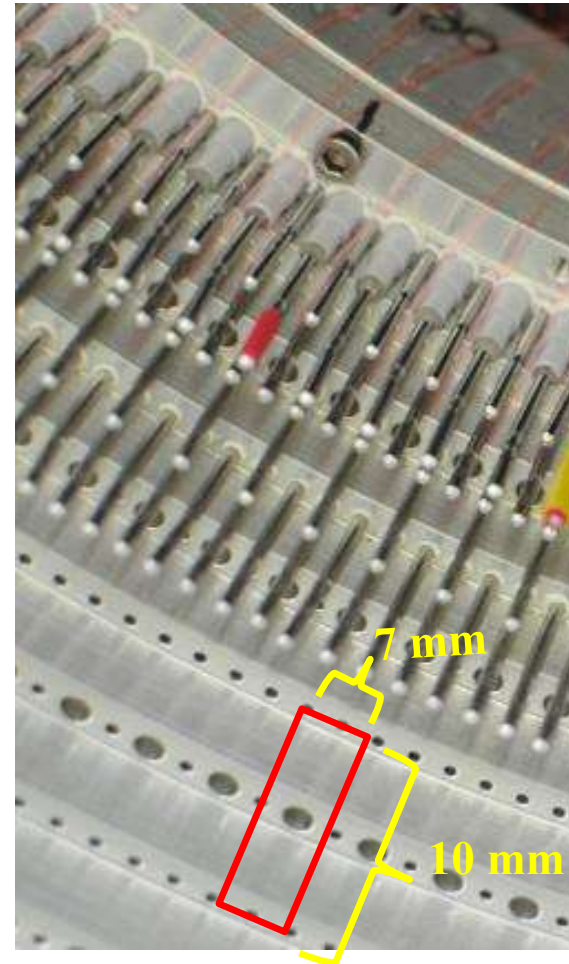
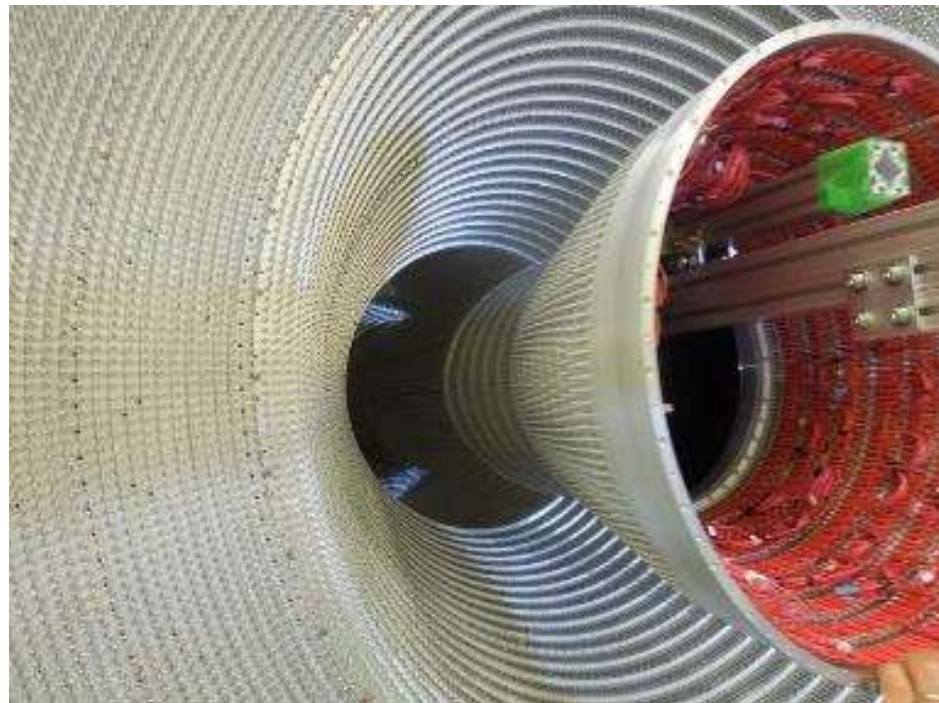

Sense :
Feedthrough

Field : without
feedthrough,
Al pin only

Installation of small cell chamber

Belle-II CDC



Installation into Belle II structure
with inner bar without touching Barrel PID

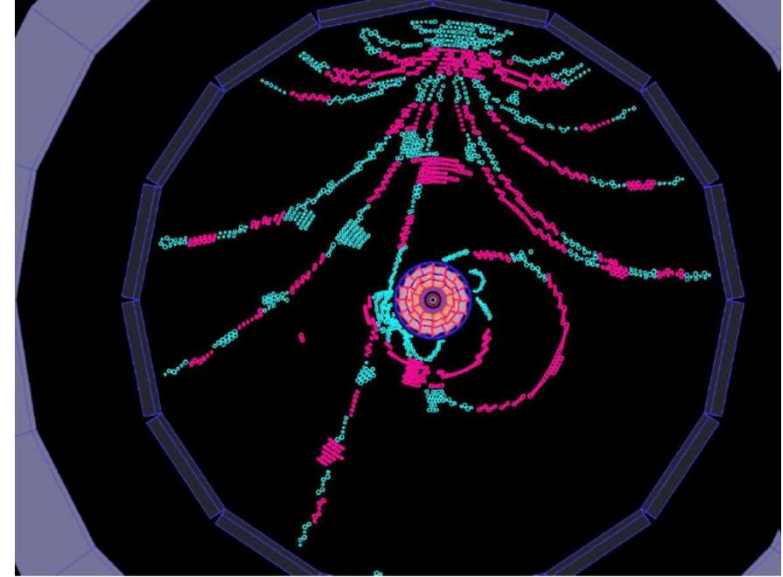

Comic ray

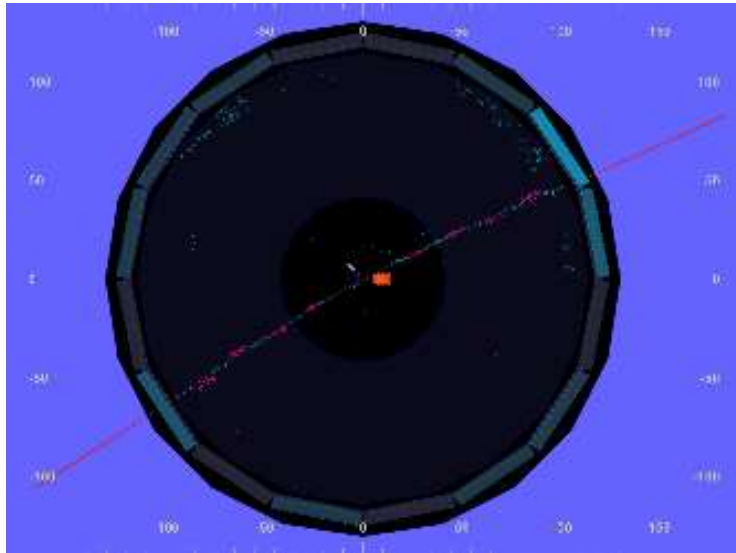

Barbar event



B-like event

XT-Curve for Belle II CDC

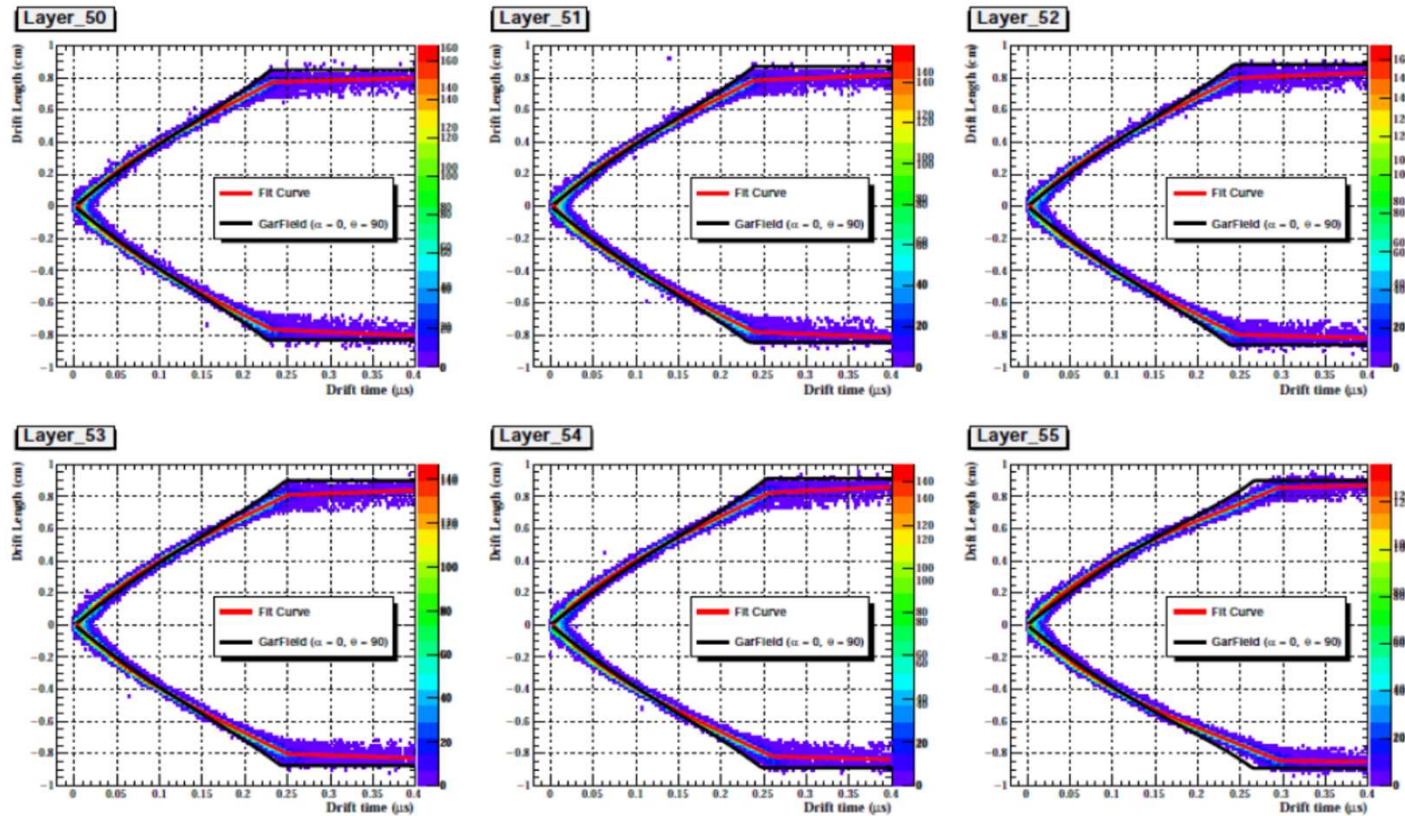

- Function: 5 order polynomial + liner function
- Theta : 7, α :18, Layer:56, LR: 2 Total: 14,112

Performance under 1.5 Tesla magnetic field

Position resolution

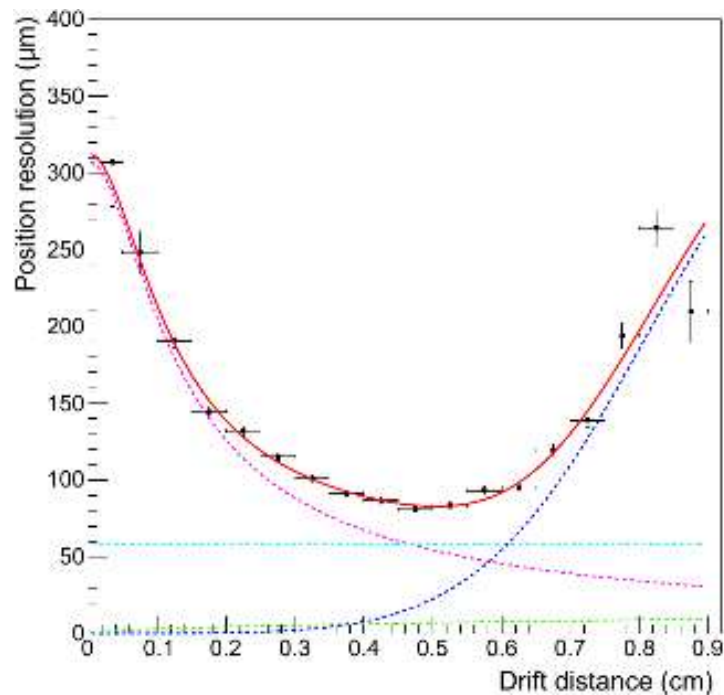

Layer 51, right, $\theta = 130^\circ$, $\alpha = -85^\circ$

Pt resolution:

$$\left((0.098 \text{ pt})^2 + (0.27)^2 \right)^{1/2} (\%)$$

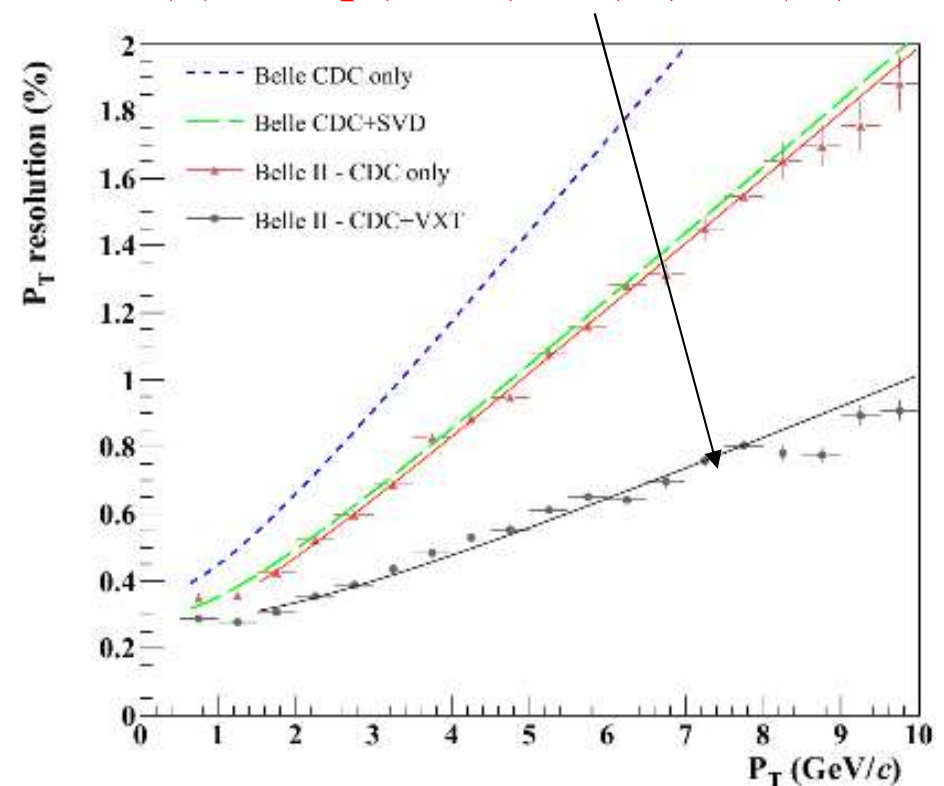

The small constant term(b) could be obtained in Belle II CDC.

$B^+ \rightarrow Dh^+$

Belle

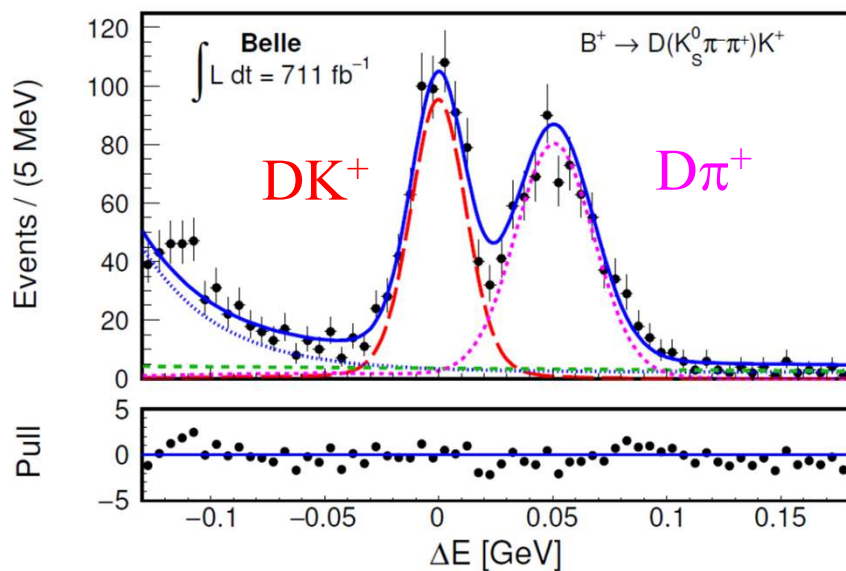
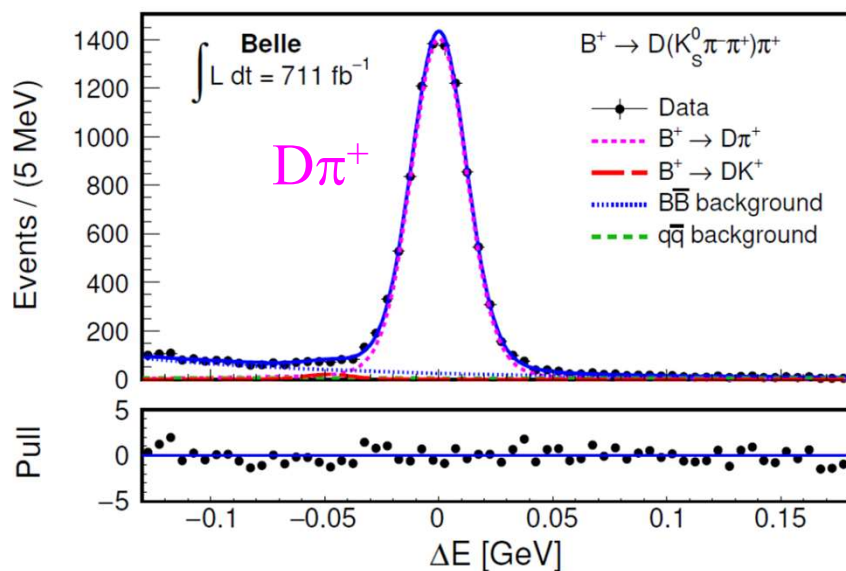

Belle II

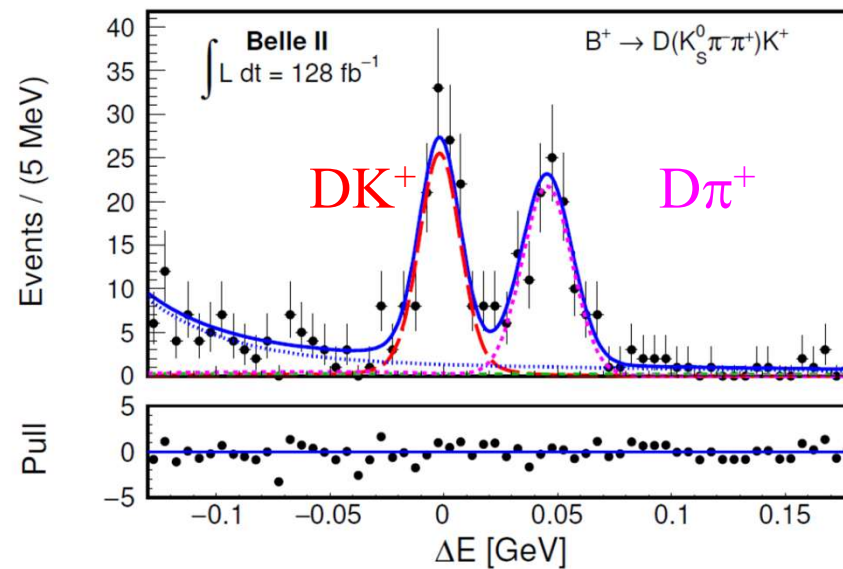
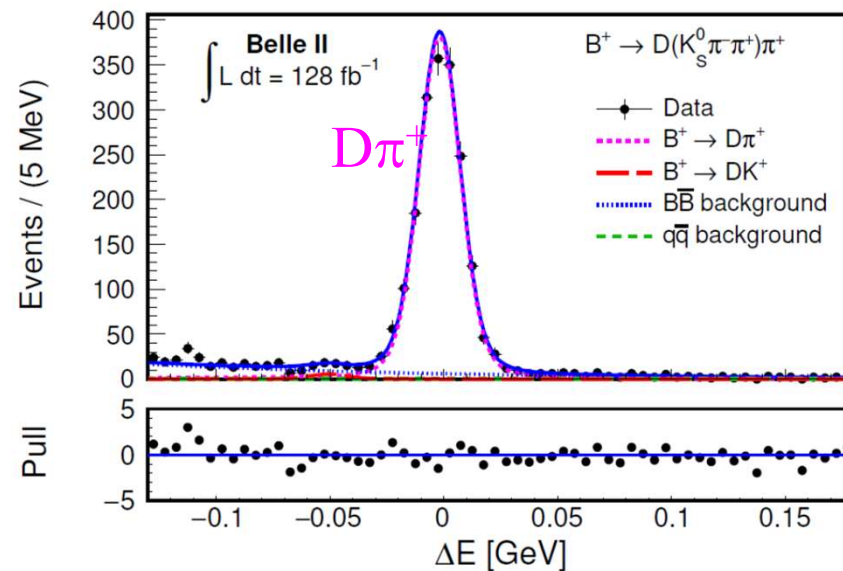

dE/dx performance

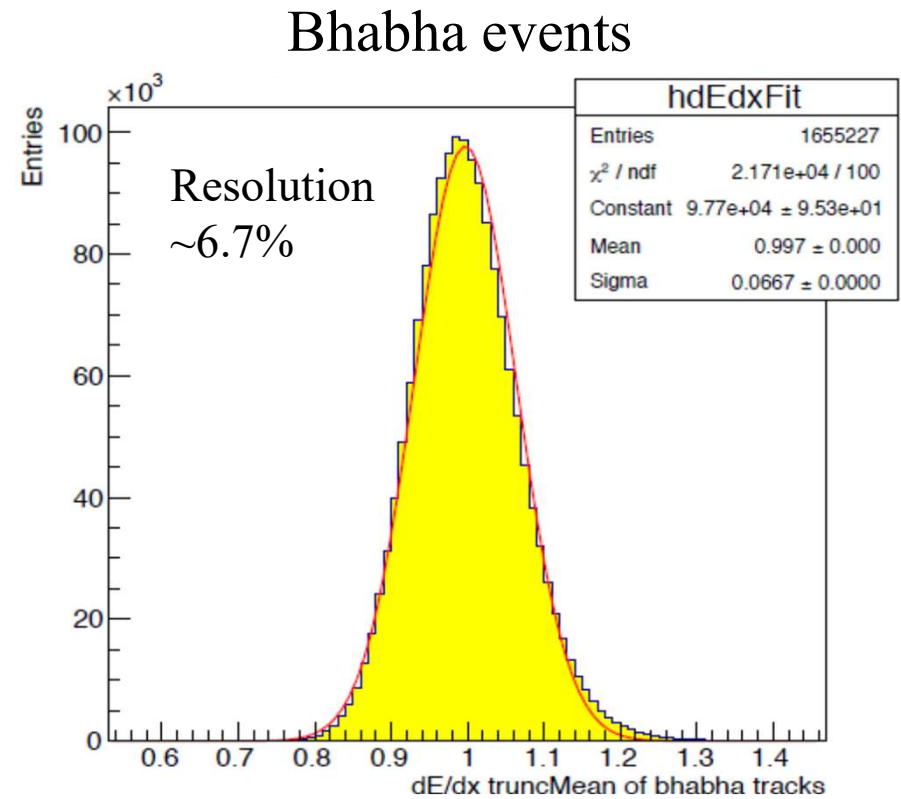
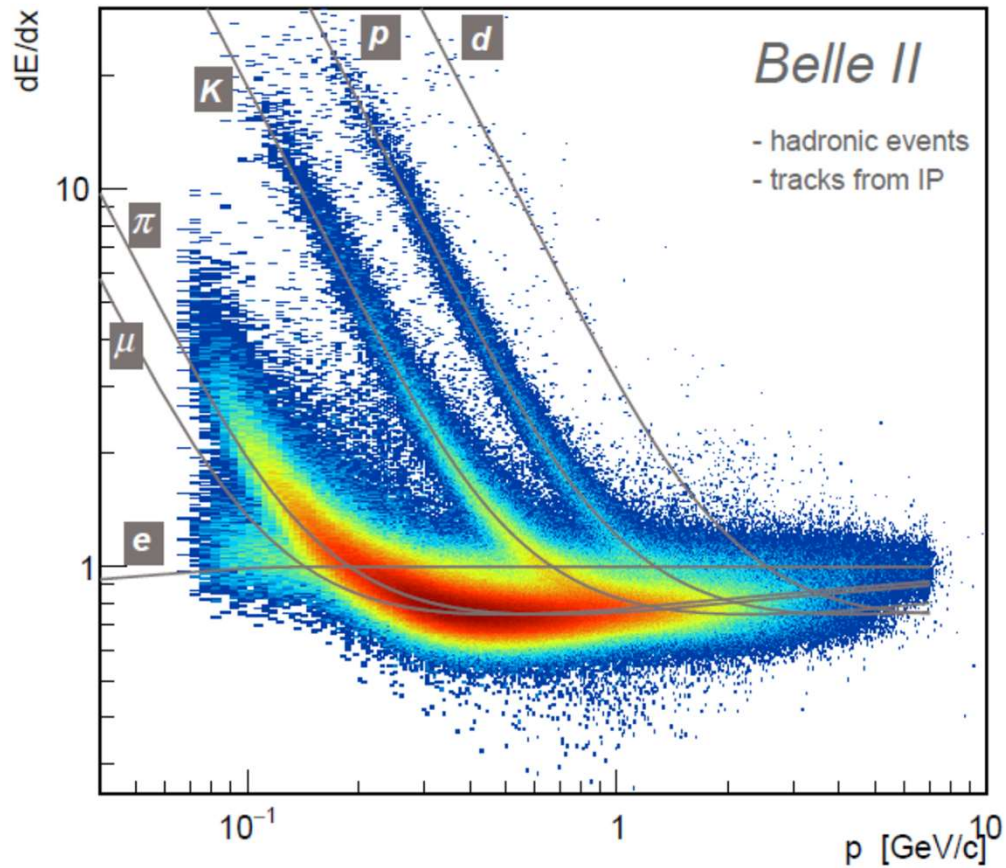

Radiation damage

- Total accumulated charge had reached up to ~ 1 C/cm in the inner most layer for 10 years Belle I CDC operation.
 - No serious performance degradation had not been observed.
- For Belle II CDC, total accumulated charge is reaching up to ~ 0.1 C/cm for the inner most layer.
 - Also, no serious radiation damage has not been observed, so far.
 - Total accumulated charge is small in the layer 0 – sector 1 due to HV trouble during the past operation. Recently, the trouble was fixed. Then, no difference is observed in the pulse height distribution as comparing with other normal sectors.

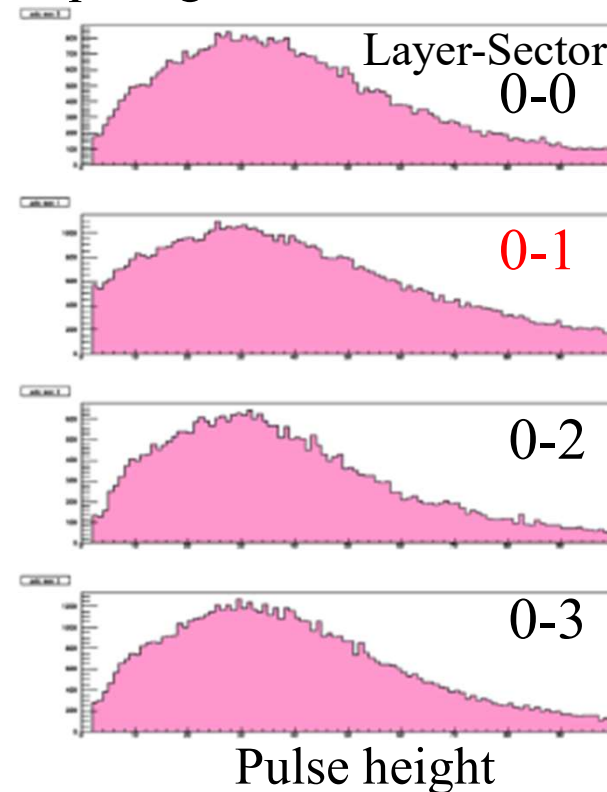
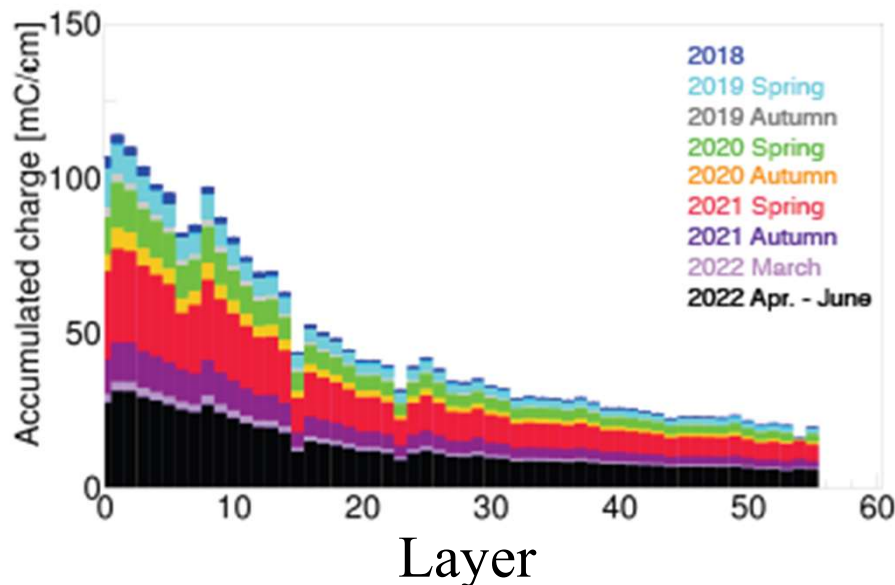

Summary

- Belle (I & II) CDC was/is working fine.
 - Small constant term for Pt resolution was obtained using low Z gas, aluminum field wire and thin inner CFRP wall.
 - Good dE/dx resolution.
- Some problems for Belle II CDC.
 - Crosstalk
 - Inside ASIC chip
 - New chip was designed and was tested.
 - New boards with new ASIC chip will be installed in the future.
 - Sudden current increase occurred in 2018.
 - Have not occurred later after adding ~2000 ppm water.
 - But, I suppose it is due to the humidity(?) at outside of chamber.

Backup

Momentum resolution (Belle I)

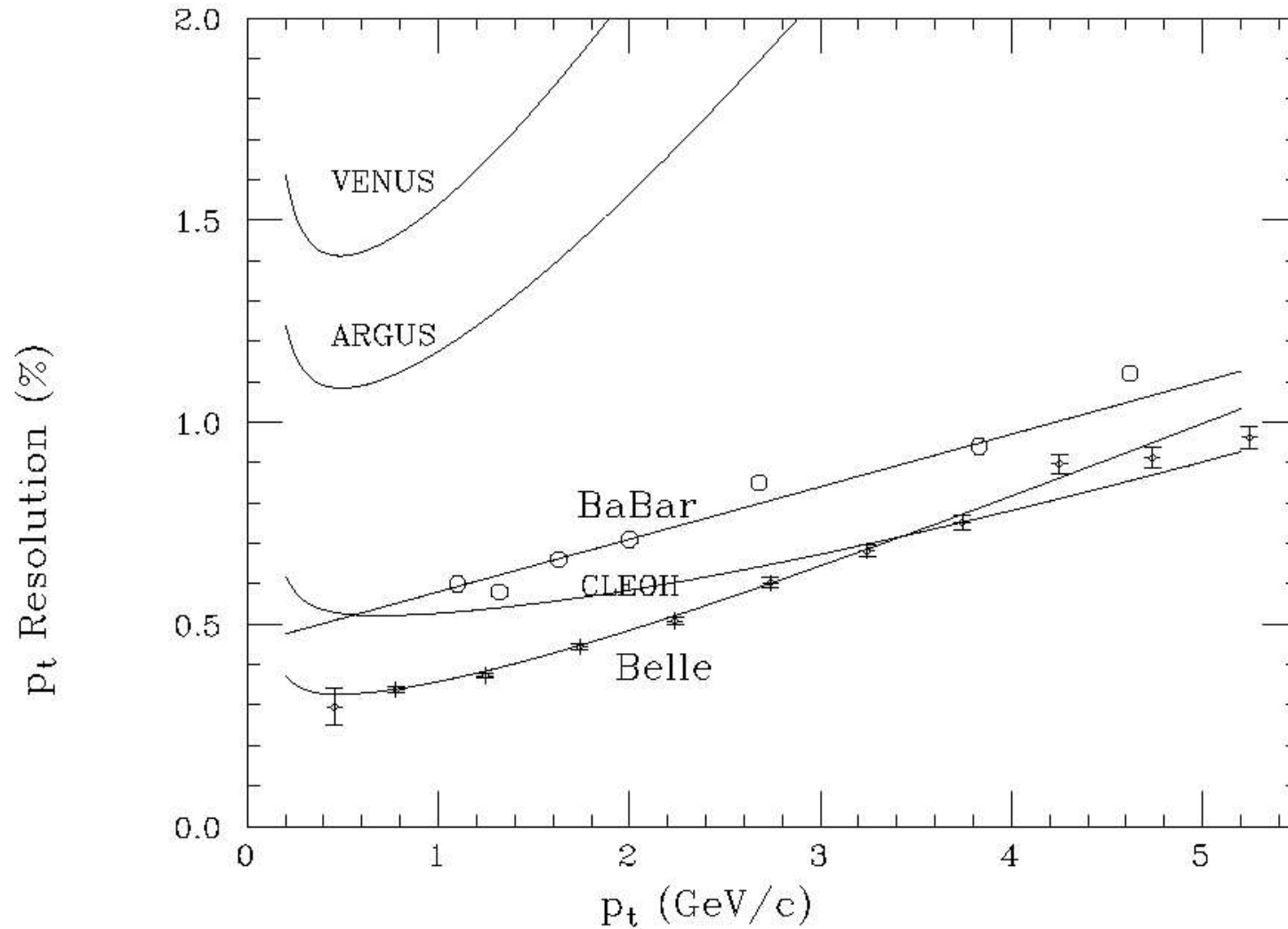

The smallest constant term(b) could be obtained in Belle CDC.

To minimize material

- Lighter gas (lower pressure)
- Lighter material of wires
- Smaller number of wires
- Thinner diameter of wires



- Better position resolution
- Better resolution of energy loss in gas volume
- Less radiation damage
- Longer stability
- Easier construction and cheaper

Selection of gas mixture

- Lower Z (atomic number) gas
 - Radiation length is proportional to square of Z .
- Drift velocity tends to saturate even in low electric field.
 - Stable performance and less calibration.
- Smaller diffusion constant
- Better resolution of energy loss.
- Less radiation damage.

Drift Velocity

- Two gas candidates for faster drift velocity were tested for Belle II CDC to obtain shorter maximum drift velocity.
 - CH_4 and He-CF_4
- In case of He-CF_4 , higher electric field is necessary to get fast drift velocity.
- In case of CH_4 , faster drift velocity by factor two or more can be obtained, even in rather lower electric field. But, Lorentz angle is too larger.

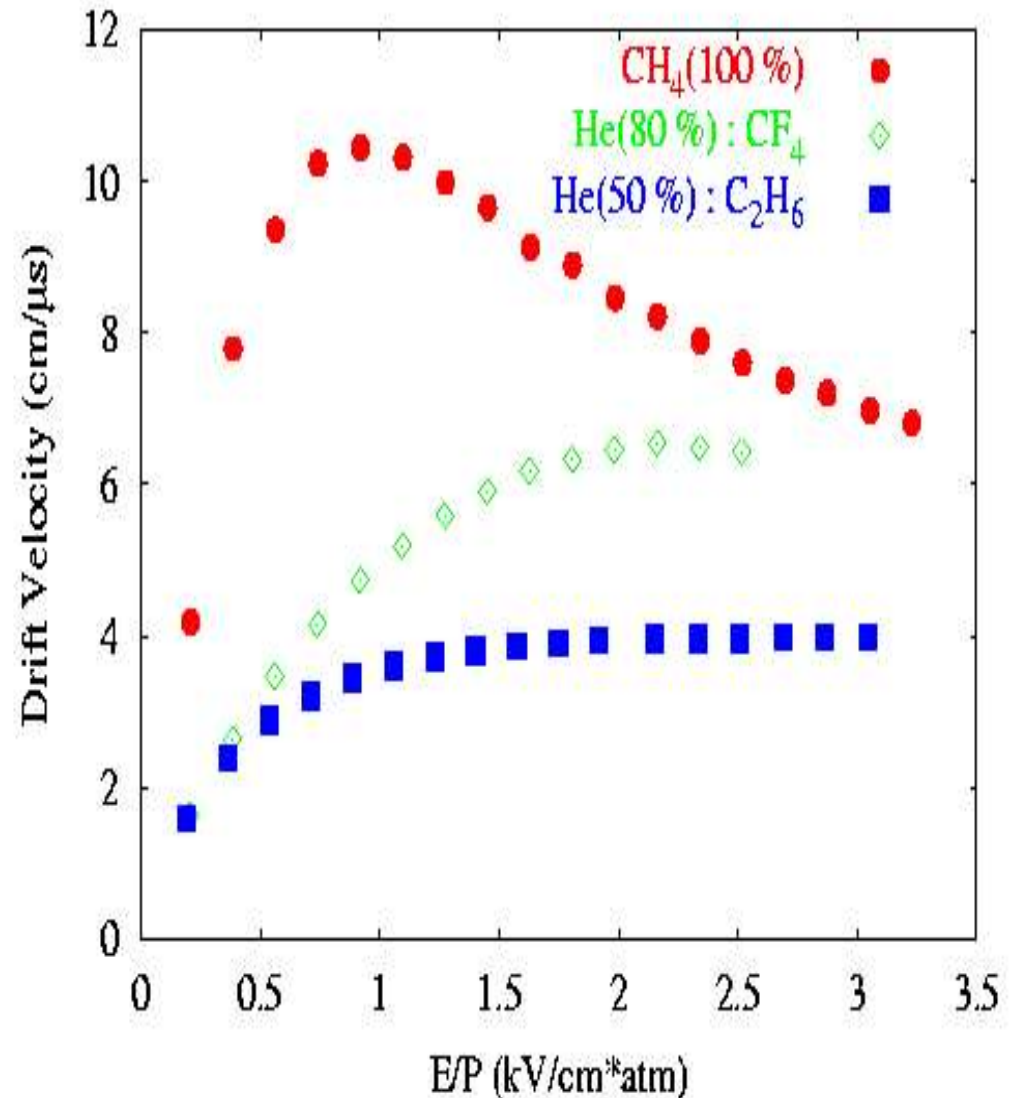

xt curve for new gas in 7mm cell under 1.5 Tesla magnetic field

He/C₂H₆ = 50/50

Pure CH₄

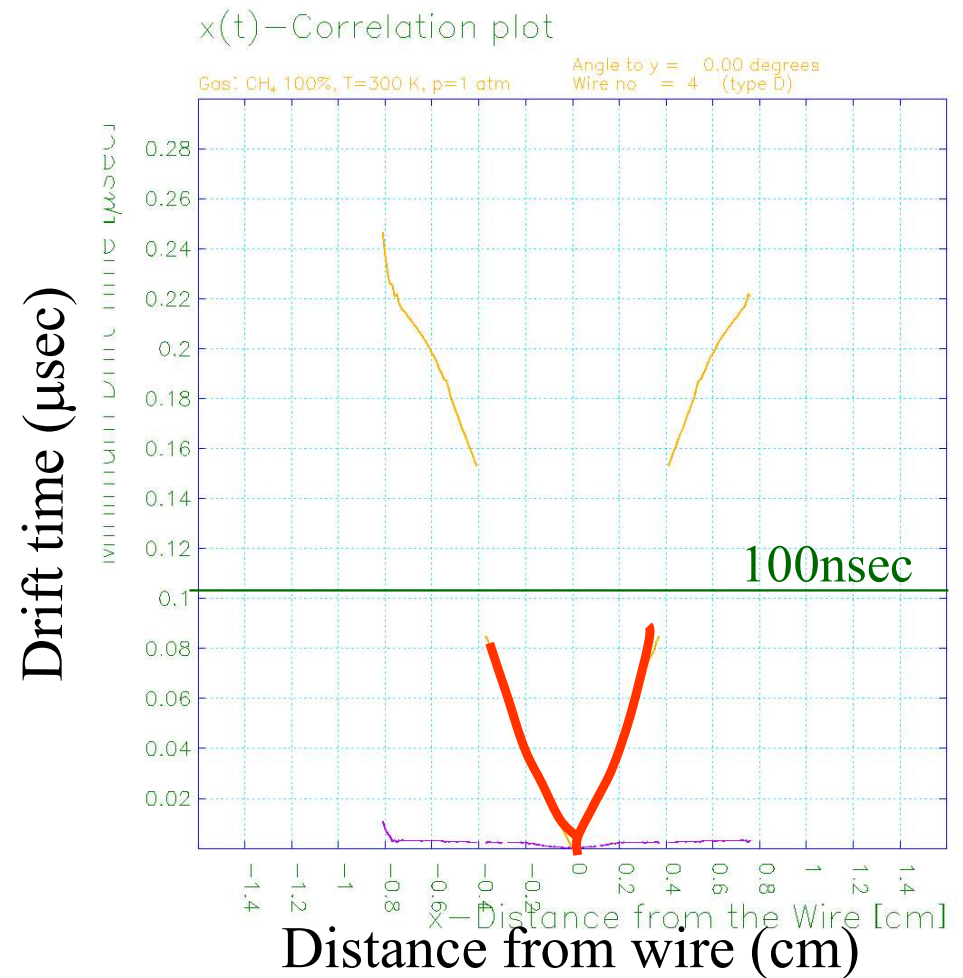
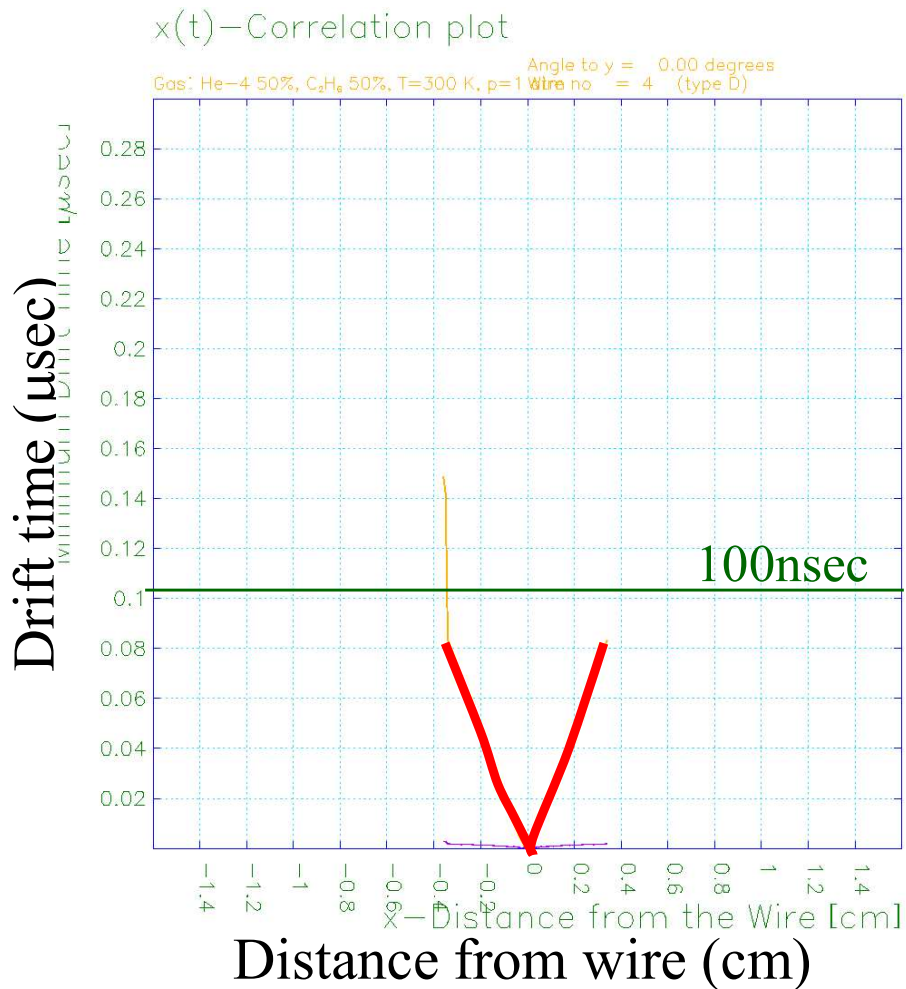

Diffusion coefficient for one electron

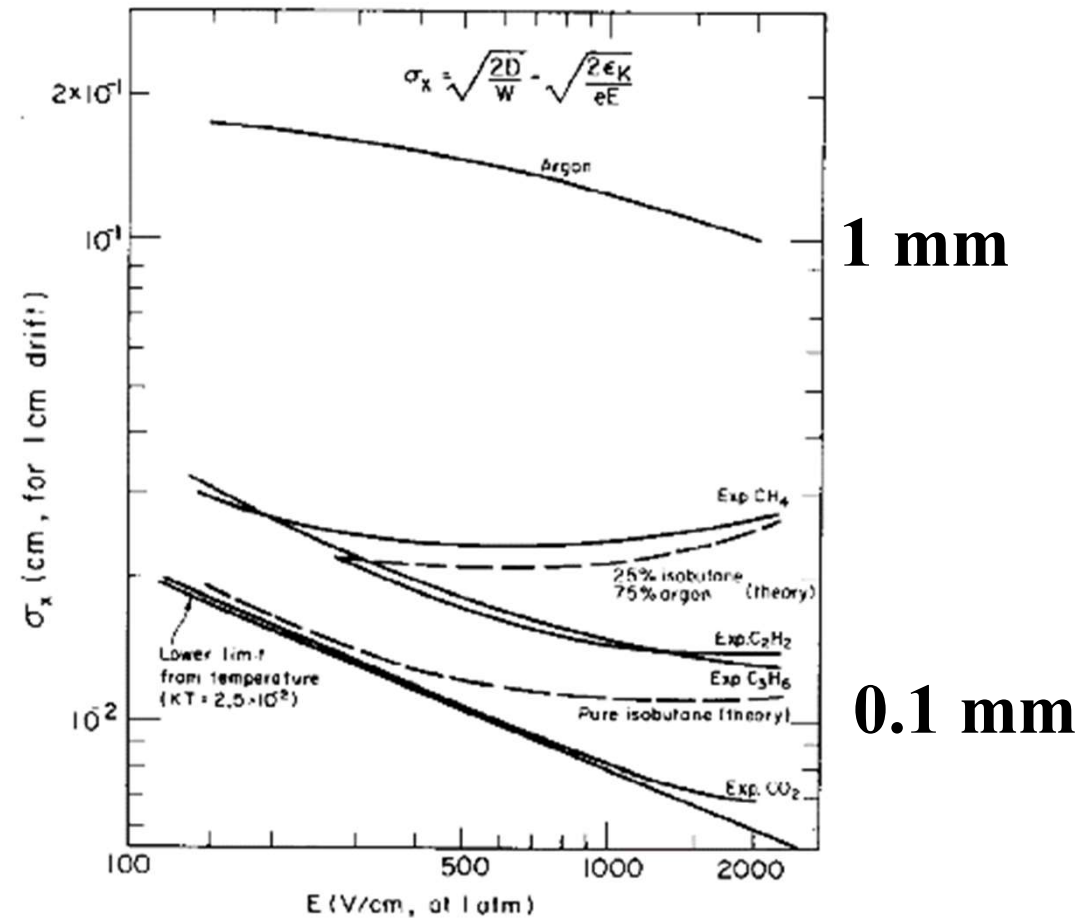

Remark : Rather large for just **one** electron

Diffusion is smaller in higher electric field.

Lorentz angle

$$\tan \alpha = c \frac{B \cdot v_0}{E}$$

α : Lorentz angle

B : Magnetic field (T)

E : Electric field (V/m)

v_0 : Drift velocity without magnetic field
(m/s)

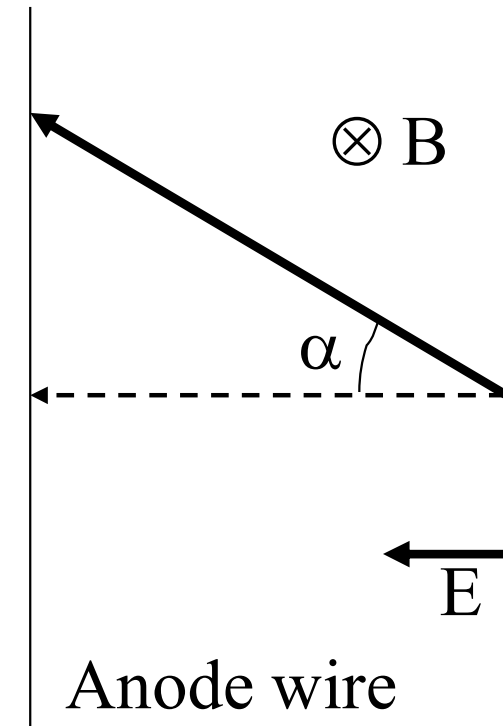

Lorentz angle becomes smaller in higher electric field.

Creep test

Al(5056) Wire (120 μ m)

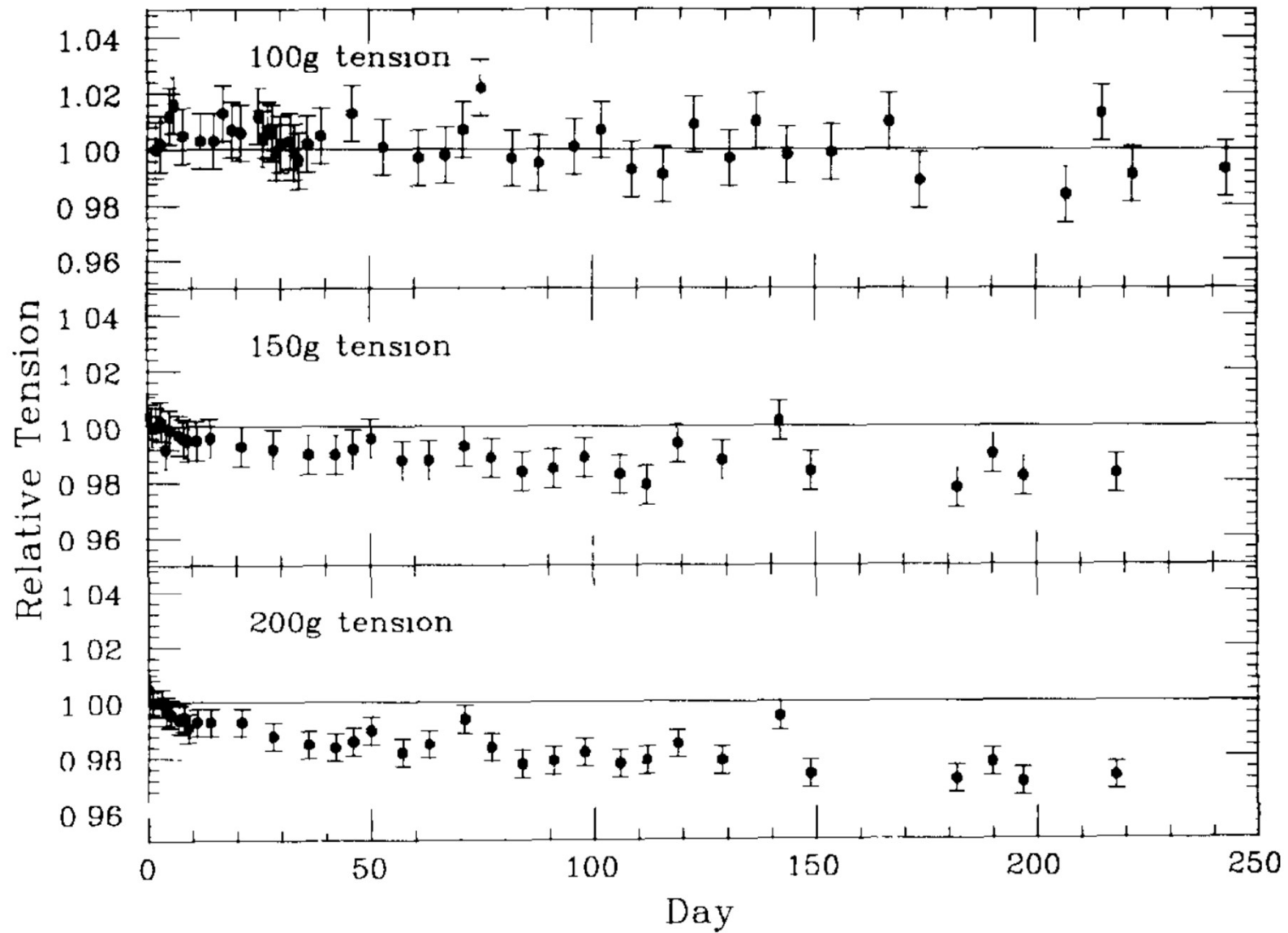

Wires

- Sense wire
 - 30 μm^ϕ gold-plated W
- Field wire
 - 126 μm^ϕ Aluminum (A5056) without any plating
- For both CDCs

Cell structure

- Rectangular shape or Hexagonal shape?
 - Number of wires
 - Goodness of electric field
 - Pass length difference along drift distance
- Cell size?
 - In case of larger cell size,
 - Number of wires decreases.
 - Increase good electric field region.
 - Higher voltage is required on the sense wires.
 - Electric field decreases in the drift region.

Simulation using Garfield

HV=2.3kV (sense wire)

B = 1.5 T, C₂H₅:50% He:50%

Positron drift lines from a wire

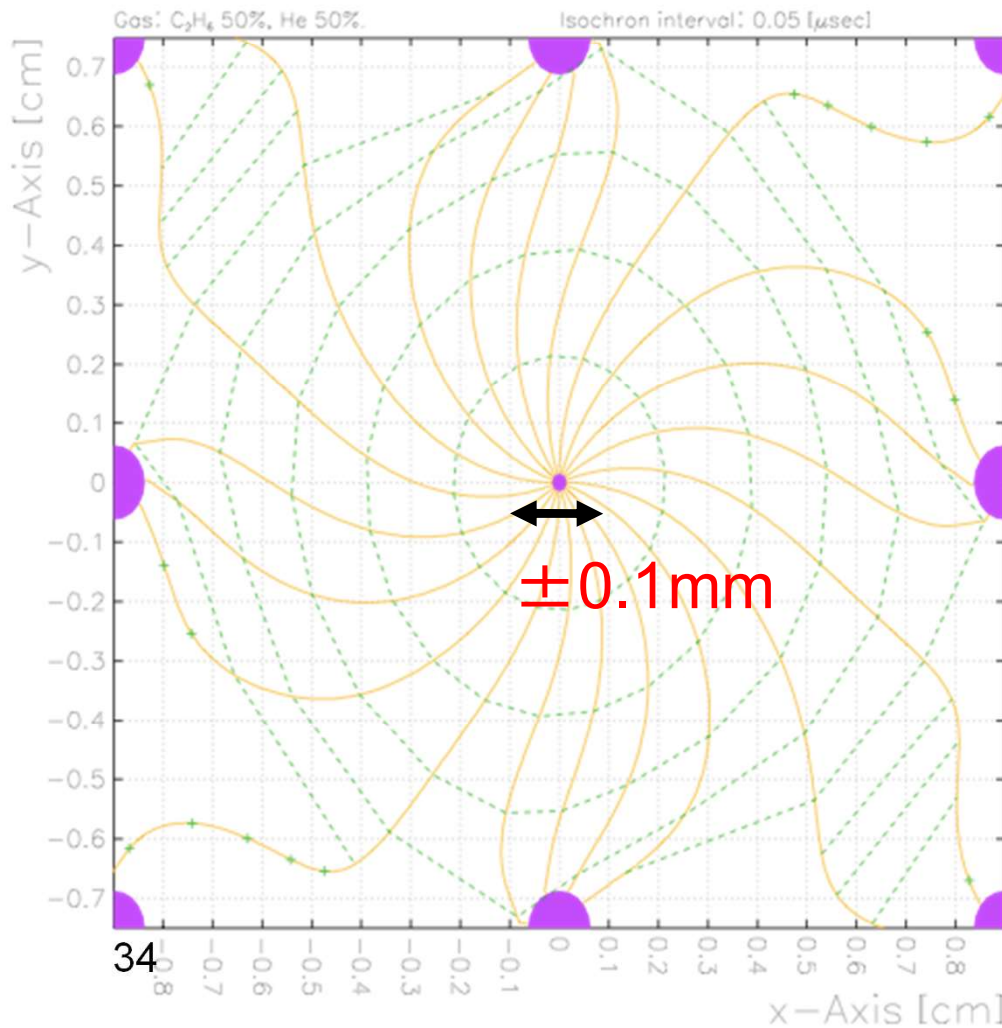

Positron drift lines from a wire

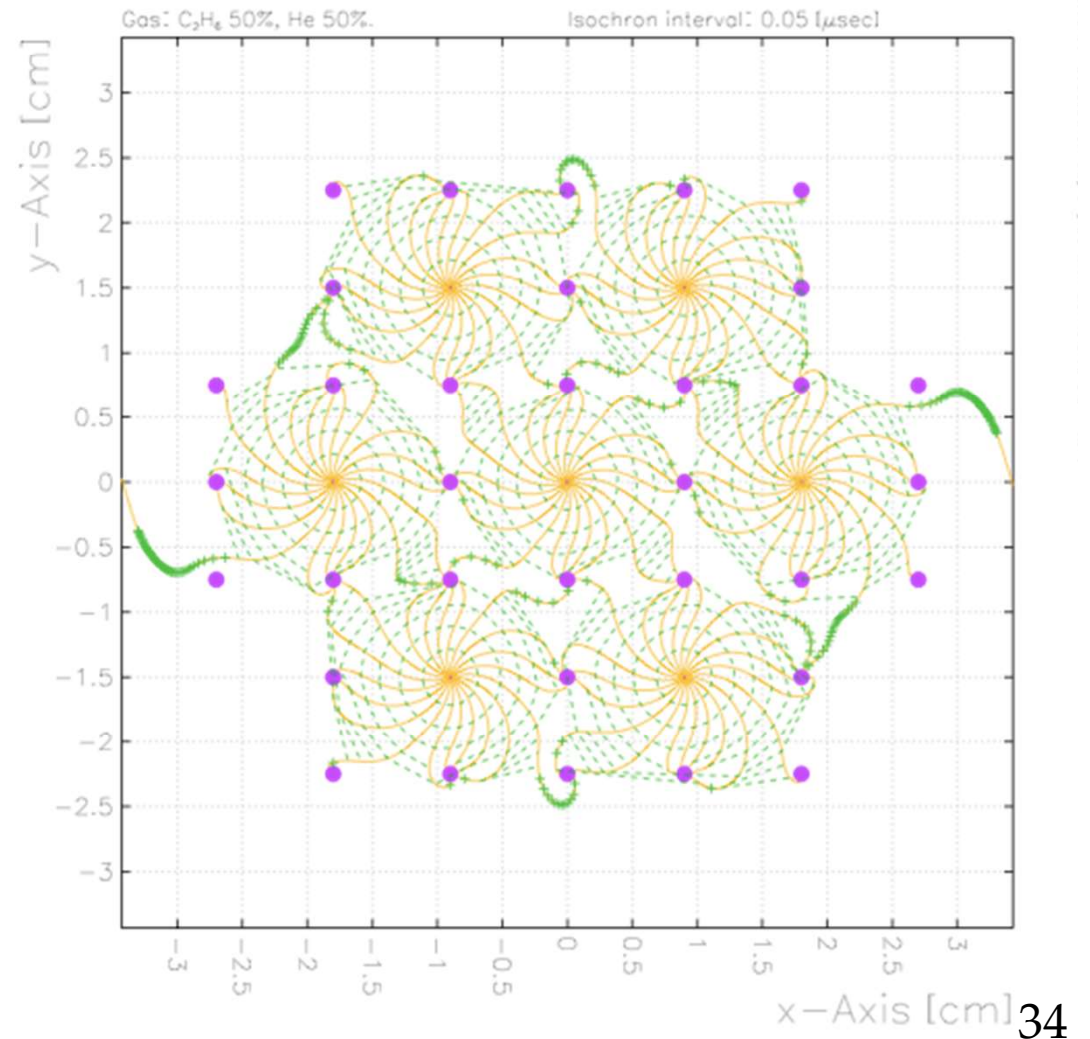

Wire configuration 1

- Super-layer structure
- 6 layers for each super-layer (Belle II)
 - at least 5 layers are required for track reconstruction.
 - Even number is preferred for preamp arrangement on support board to shorten signal cable between feed-through and preamp.
- Additional two layers in inner most super-layer (Belle II).
 - Higher hit rate in a few layers near wall.
 - Two inner most layers are considered as active guard wire.

Wire configuration 2 (Belle II)

- 9 super-layers : 5 axial + 4 stereo(2U+2V)
 - A 160*8, U 160*6, A 192*6, V 224*6,
 - A 256*6, U 288*6, A 320*6, V 352*6, A 388*6
- Number of layers : 56
- Number of total sense wires : 14336
- Number of total wires : 56576

Deformation of endplate

- Number of wires increase by factor 2 as compared with Belle I.
 - Larger deformation of endplate is expected.
 - It may cause troubles in a wire stringing process and other occasions.
- Number of holes increases, but a chamber radius also enlarges. Cell size is changing as a function of radius to reduce number of wires.
 - The fraction of holes respect to total area is not so different, as comparing with the present CDC.
 - 11.7% for present CDC
 - 12.6% for Super-Belle CDC
- In order to reduce deformation of endplates,
 - The endplate with a different shape is considered.
 - Wire tension of field wires will be reduced.
- Anyway, we can arrange the wire configuration and can make a thin aluminum endplate.

Radiation damage

- Radiation damage depends on various condition dramatically.
- No problem for usual gas (Argon Methane).
- Impurity and out gas from chamber material may cause troubles.
- There are two different types of damages on cathode wire surface and anode wire surface.
 - When electric field on the surface of cathode wire exceeds some level ($>20\text{kV/cm}$), gas multiplication occurs. Then, something accumulate on the surface of the cathode wires quickly.
 - This is so-called Malter effect. Frequent sparks occur suddenly and high voltage cannot be supplied.
 - Gas gain decreases continuously due to accumulation of something on the surface of anode wires.

Radiation Damage Test

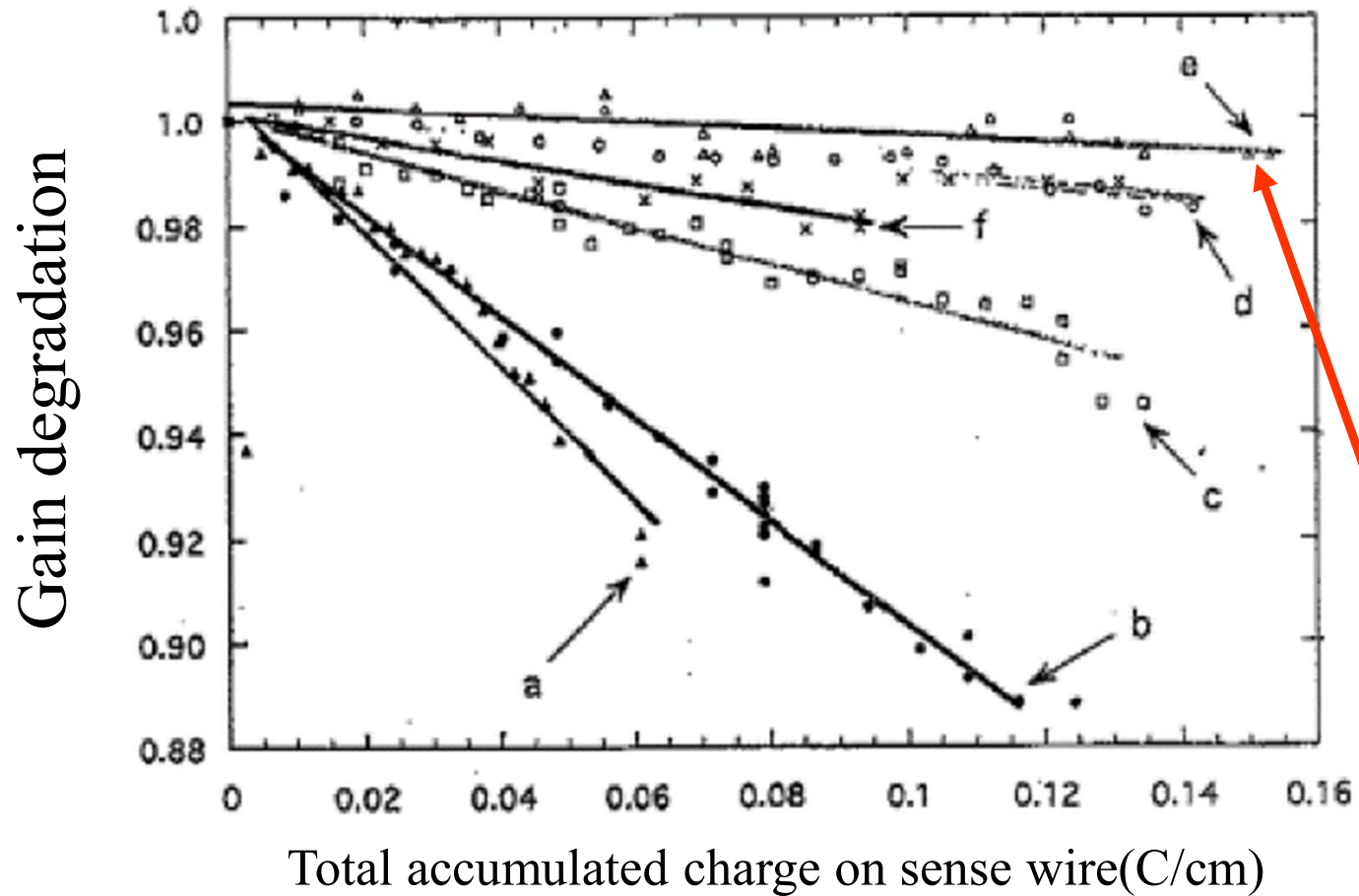

a: '93 Plastic tube

b: '93 Plastic tube + O₂ filter

c: '94 Plastic tube

d: '94 SUS tube

e: '94 SUS tube + O₂ filter

f: '94 Plastic tube

Main parameters

	Belle	Belle-II
Radius of inner boundary (mm)	77	160
Radius of outer boundary (mm)	880	1130
Radius of inner most sense wire (mm)	88	168
Radius of outer most sense wire (mm)	863	1111.4
Number of layers	50	56
Number of total sense wires	8400	14336
Effective radius of dE/dx measurement (mm)	752	944
Gas	He-C ₂ H ₆	He-C ₂ H ₆
Diameter of sense wire (μm)	30	30



CDC Structure

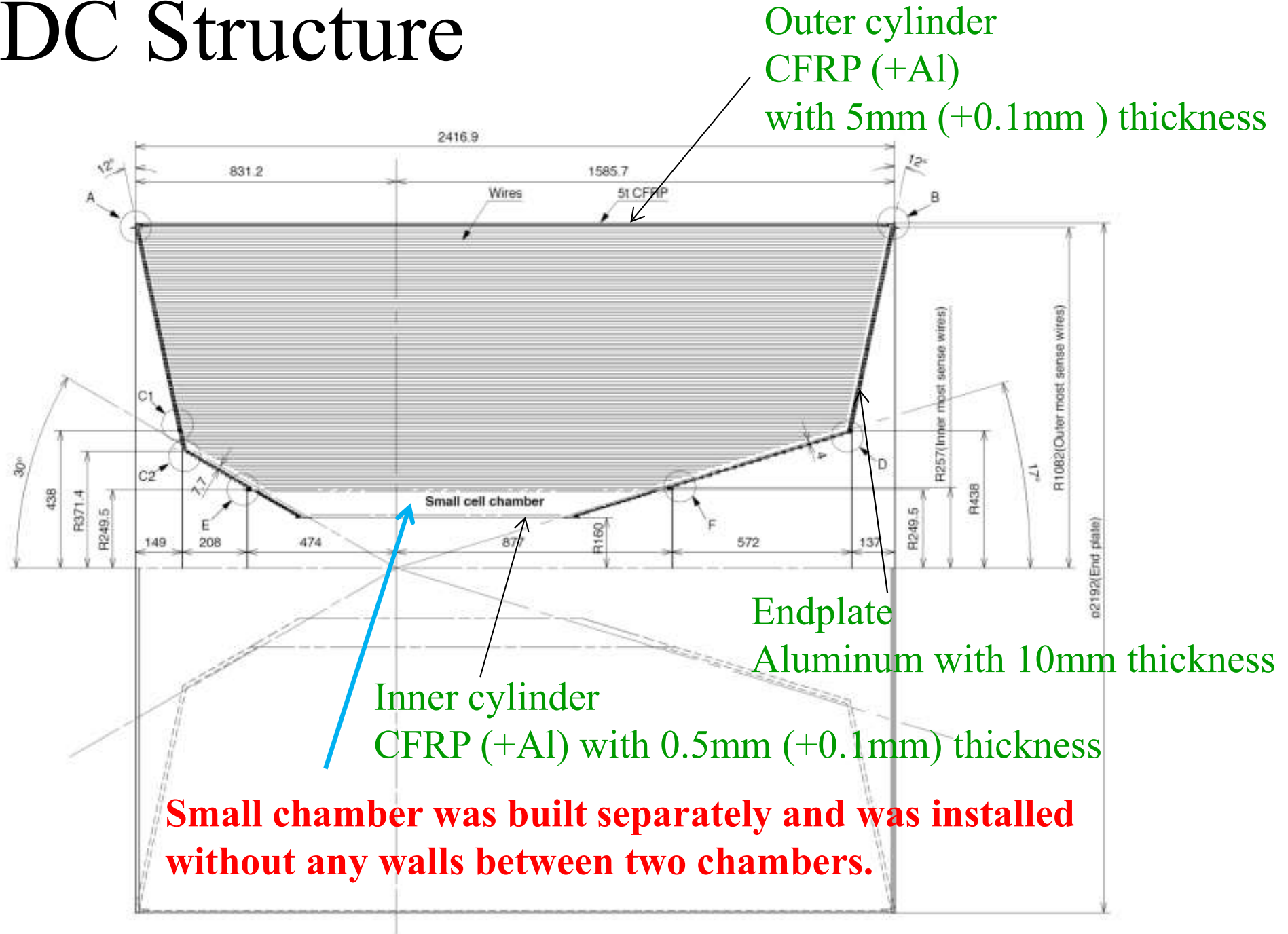

Small chamber was built separately and was installed without any walls between two chambers.

Electronics for Belle-II CDC

About readout electronics

- **For Belle-I CDC,**
 - S/QT + multi-hit TDC
 - S/QT : Q to Time conversion
 - FASTBUS TDC was replaced with pipeline COPPER TDC.
- **Three options,**
 - High speed FADC(>200MHz)
 - Pipeline TDC + Slow FADC(~20MHz)
 - ASD chip + TMC(or new TDC using FPGA) + slow FADC near detector.
 - ASIC group of KEK Detector Technology Project is developing new ASD chip.
 - New TDC using FPGA is one candidate for TDC near detector.

Signal Shape

- Each signal shape is not same.
- Rise time : $\sim 10\text{nsec}$, Pulse width : $\sim 300\text{nsec}$.
- Maximum drift time : $\sim 300\text{nsec}$

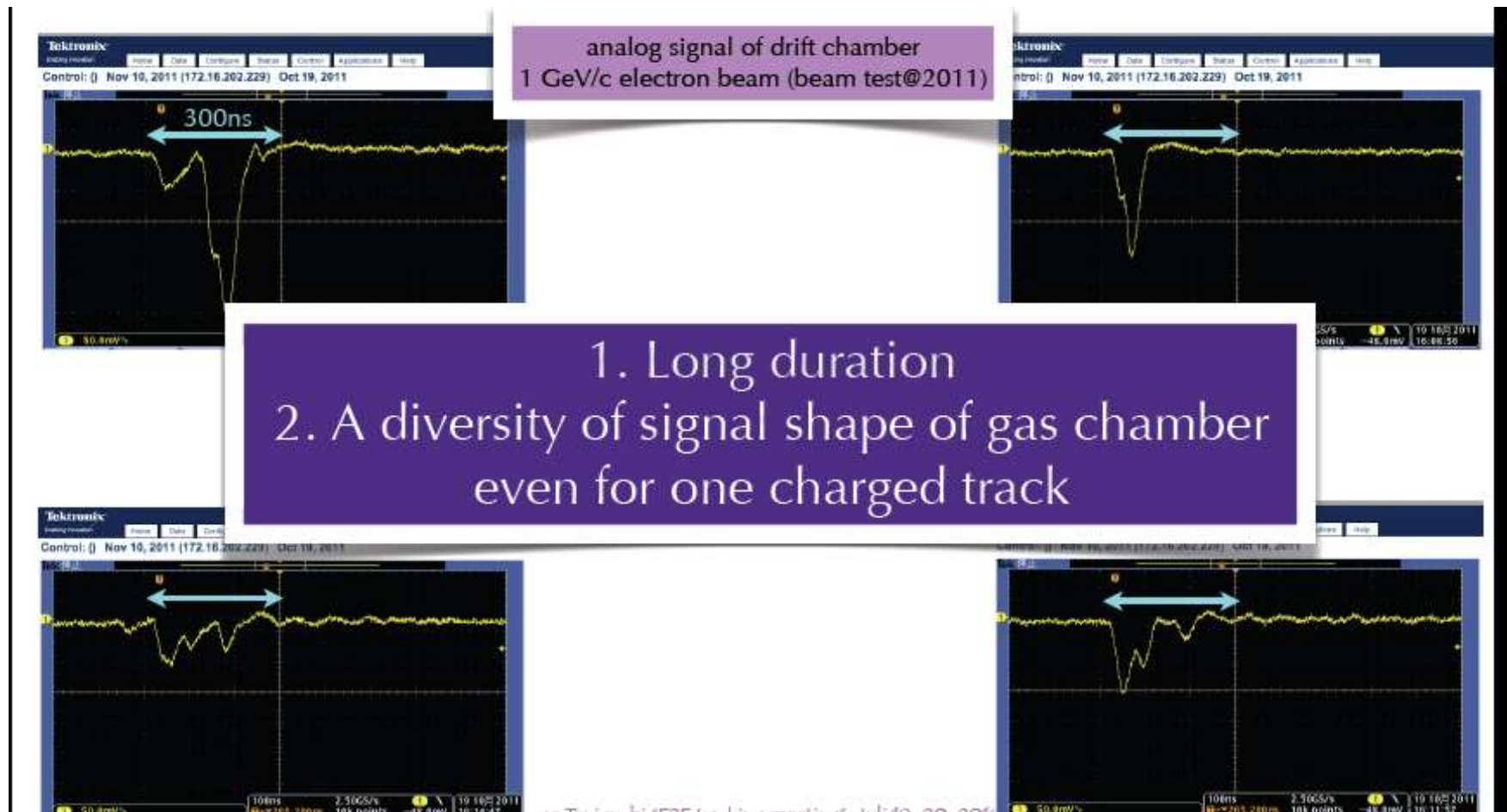

Signal shape

$B=1.5T$

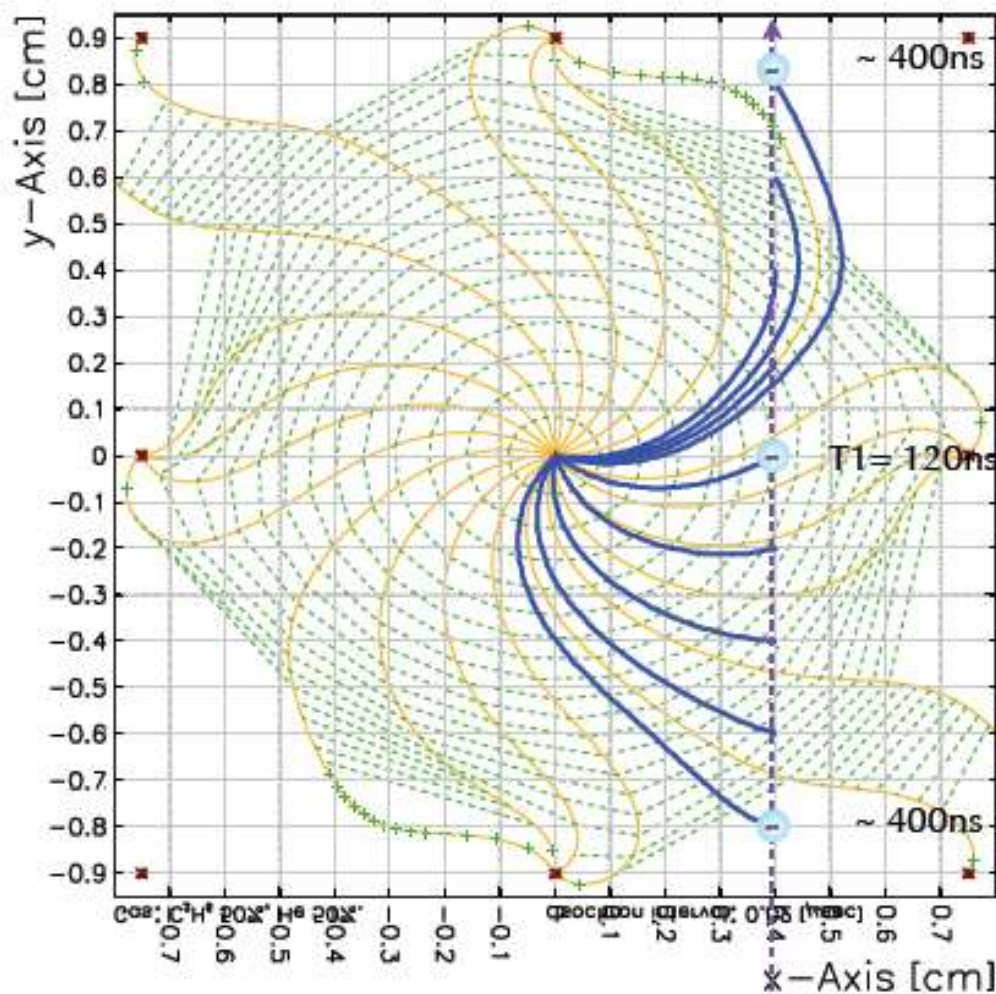

arrival time difference $> 300\text{nsec}$

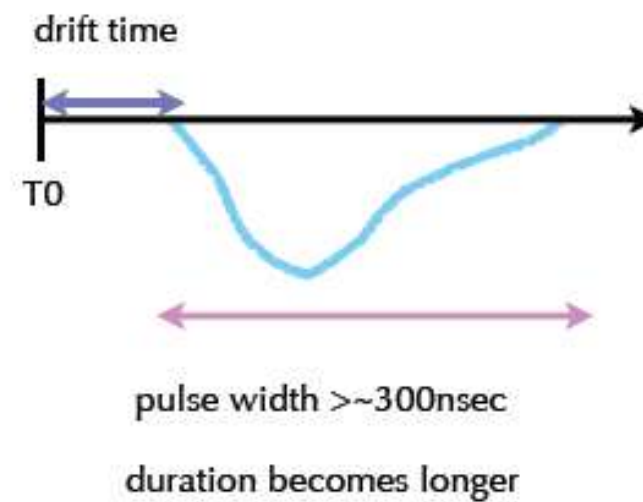

1-charged particle track

Nanae Taniguchi "F2F tracking meeting", Juli 19-20, 2012

ASIC

Amp-Shaper-Discriminator (ASD) chip

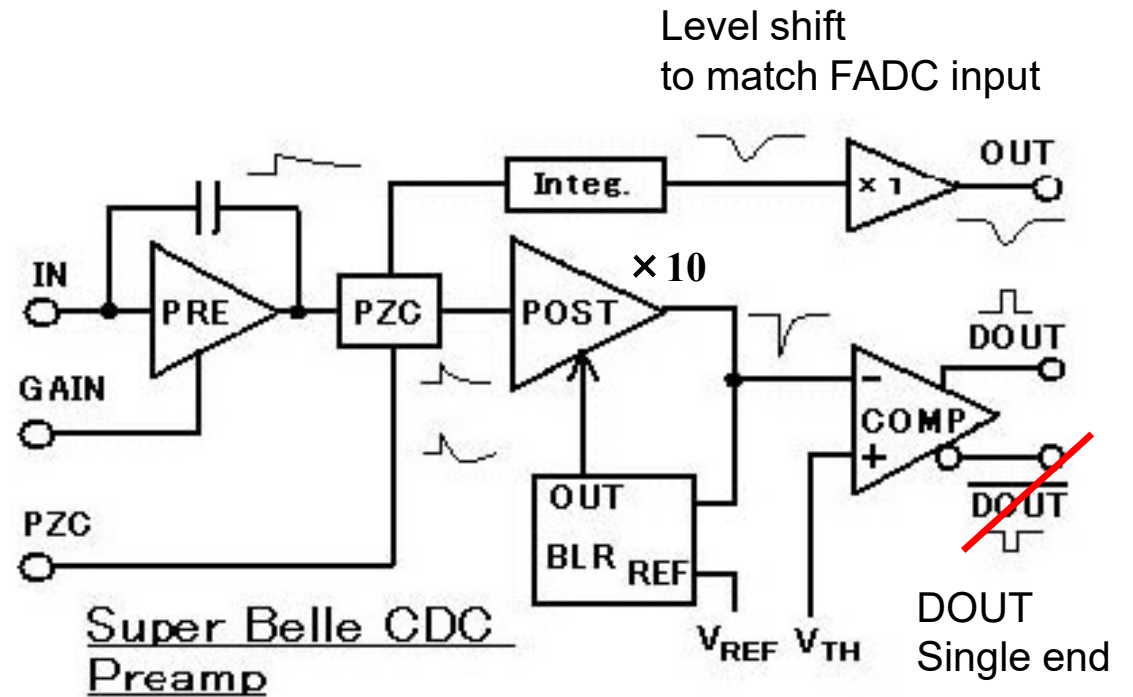

Specifications

Parameter	Value
# of Chs.	8
Analog gain	-1.1V/pC
Peaking time	8 ns
Noise	4000 e @Cd=20 pF
Power	+5V, +3.3V
Power consumption	34mW/ch
Process	BiCMOS 0.8 μm

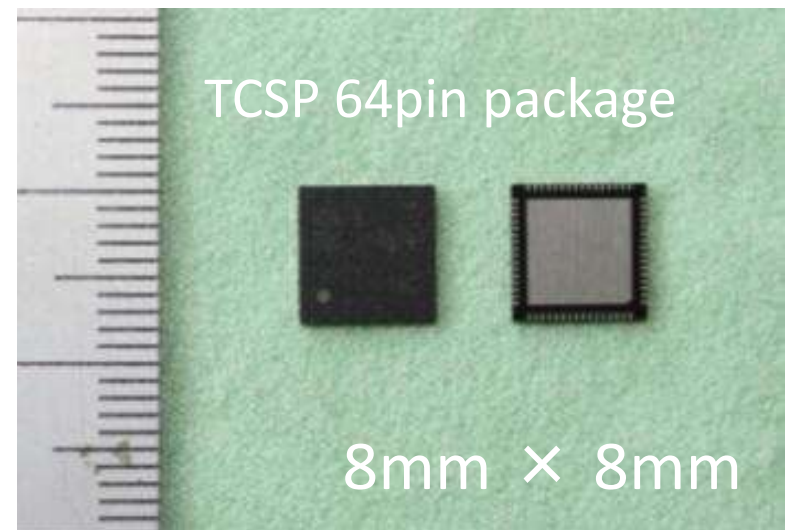

Block diagram

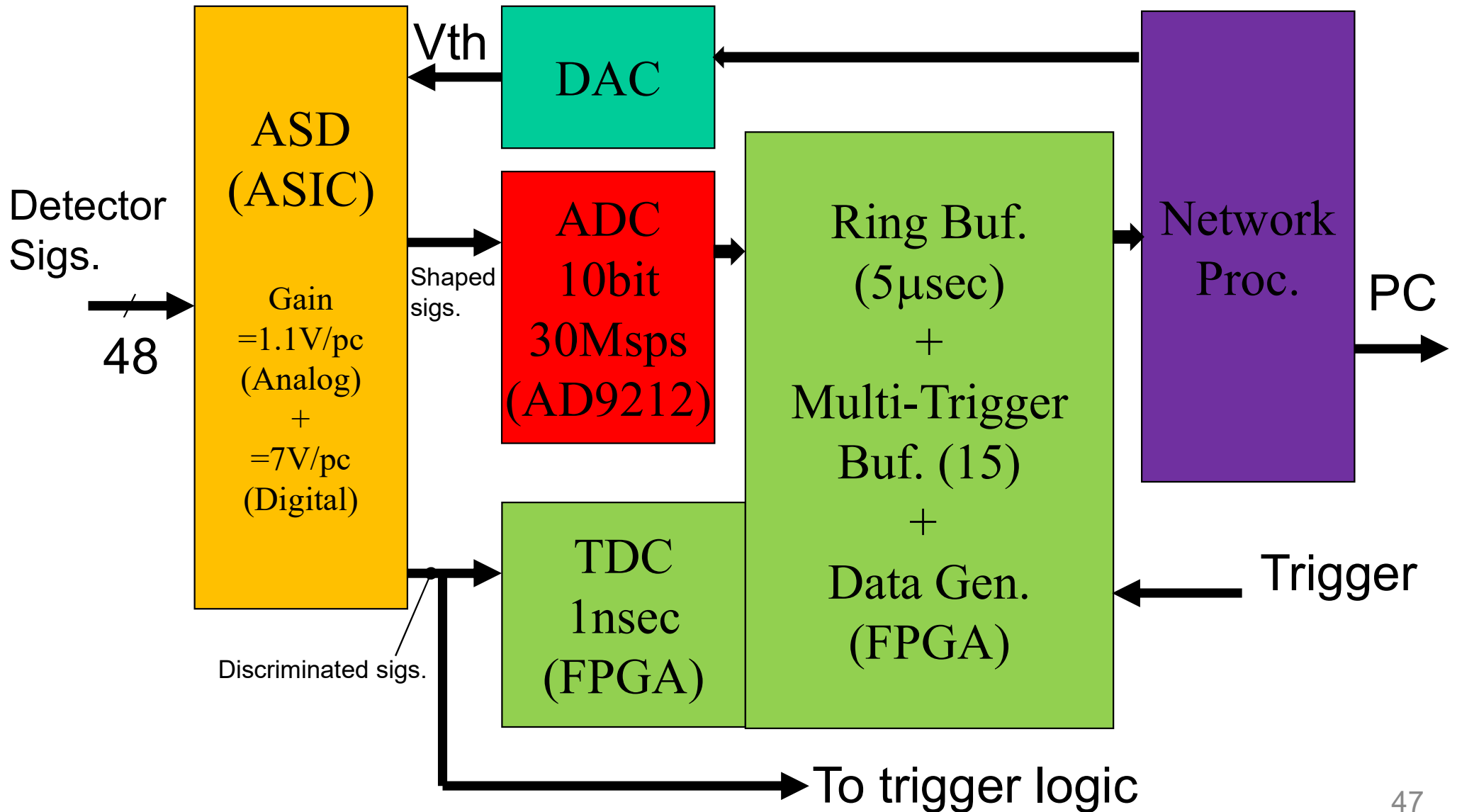

読み出し電子回路



CDC readout electronics

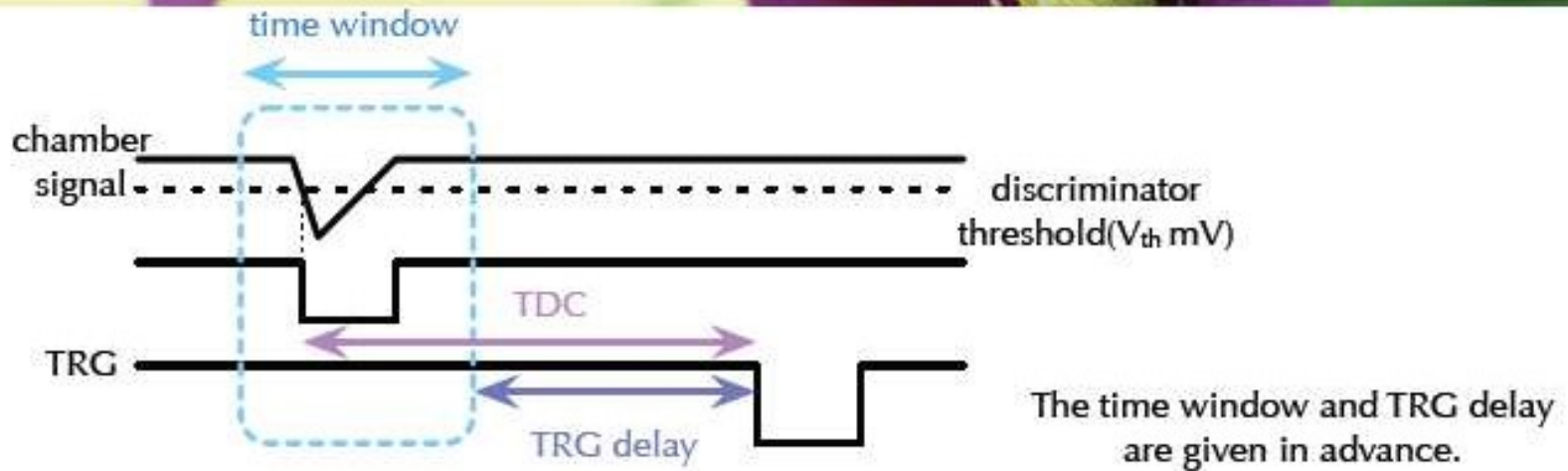

function

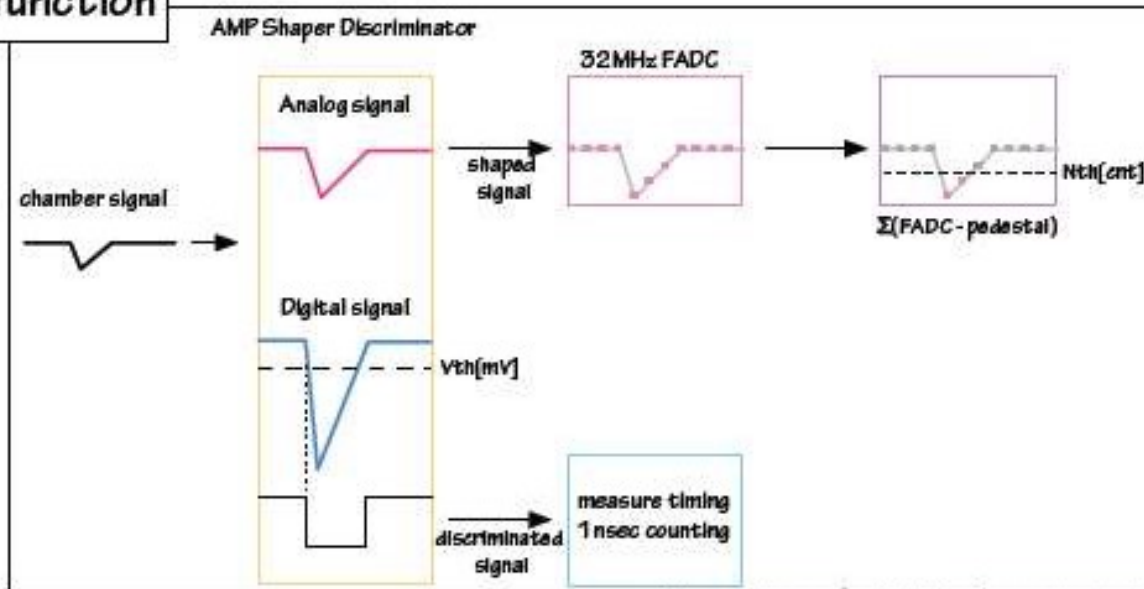

summed FADC
(dE/dx)

TDC
(drift time)

TDC hit is required

DAQ
system

Small cell chamber

Feedthrough

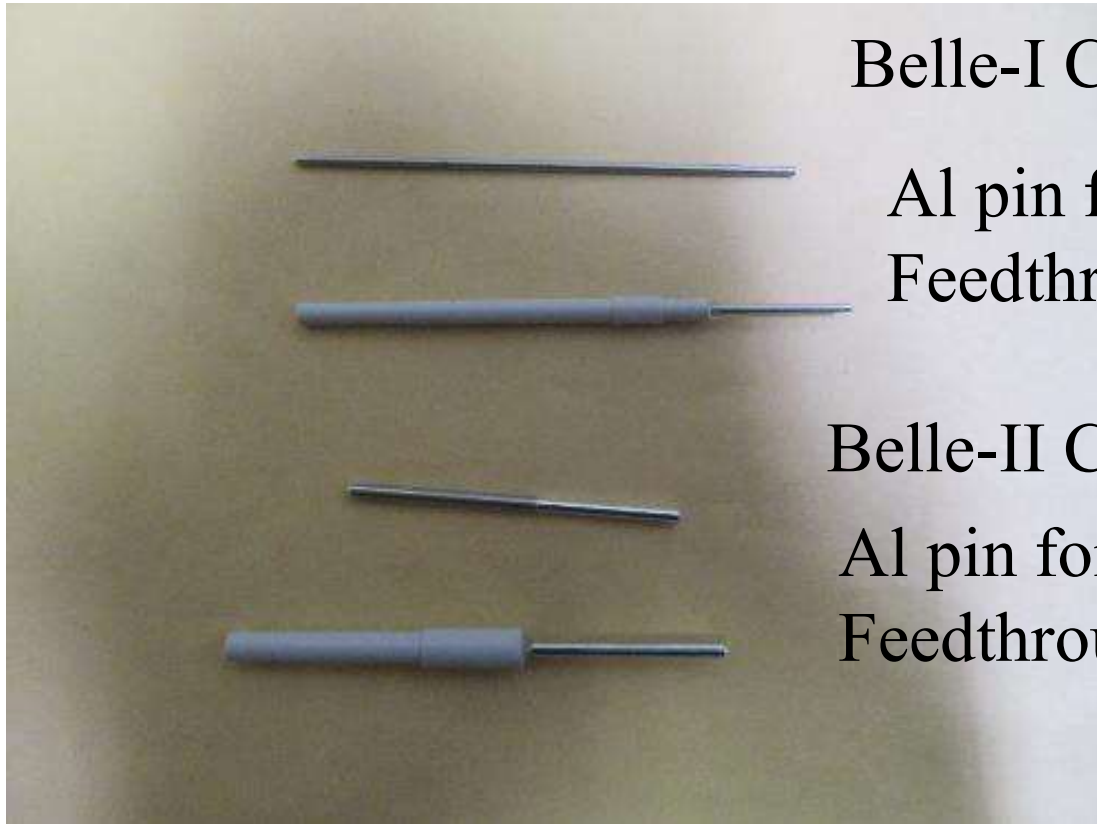

Belle-I CDC small cell chamber

Al pin for field wire $1\text{mm}\phi$

Feedthrough for sense wire $3\text{mm}\phi$

Belle-II CDC small cell chamber

Al pin for field wire $1.6\text{mm}\phi + 1.4\text{mm}\phi$

Feedthrough for sense wire $4\text{mm}\phi$

Material of aluminum pin : A5052

Material of feedthrough : Noryl

Shape and diameter for holes

Belle-I



1.0mm ϕ + 0.8mm ϕ for field wire

3.0mm ϕ for sense wire

Minimum distance

between two holes:2.5mm

Belle-II

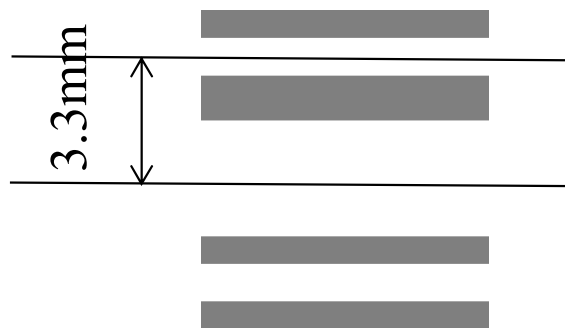

1.6mm ϕ for field wire

4.0mm ϕ for sense wire

Minimum distance

between two holes:3.3mm

How to fix the wire

- Wire pass through the hole ($\sim 0.3\text{mm}^\phi$) and is fixed by **crimping**.
- Feedthrough has a taper shape from the gas side.
 - We can put the wire easily into the hole of the aluminum pin with feedthrough for the sense wire.
- For the field wire,
 - There is aluminum pin only without feedthrough.
 - It is slightly difficult to put the field wire into the hole of aluminum pin directly. But, it is possible for Japanese and a student from Thailand.

Shape of one of feedthroughs

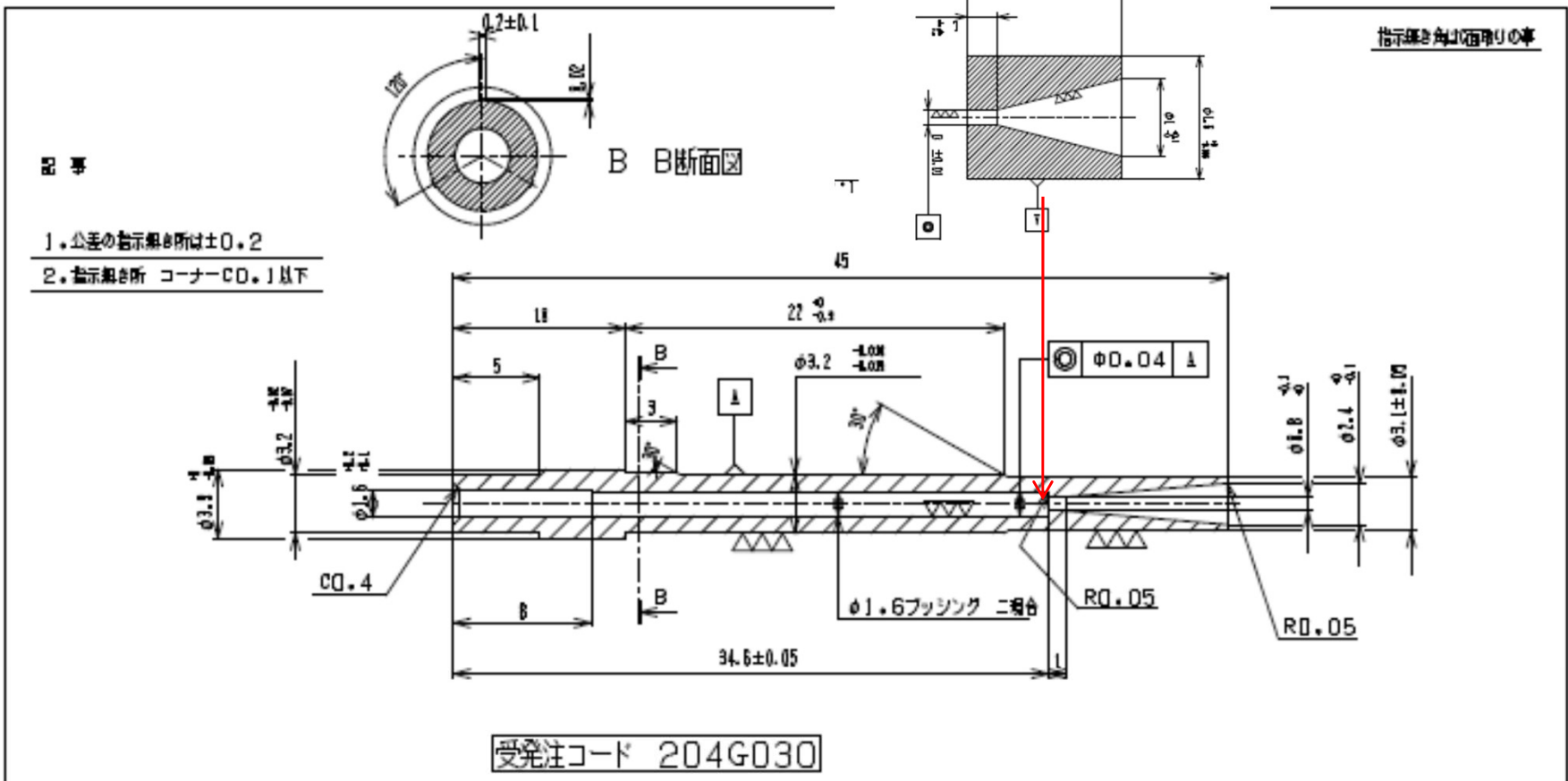

△			材質	ノリル6E90	数量	3x1.0mm	林 栄 精 器 株 式 会 社							
△			表面処理	表面処理	備考	備考	名 称 ノリルTypeフィードスルー							
△			設計・製図	平 尾	年月日	2011-07-26	Φ4スリーブ							
△			検閲・承認				尺 度	3/L	単 位	1.0mm	分 類	F-397	図 番	P-1

Belle-I CDC small cell chamber

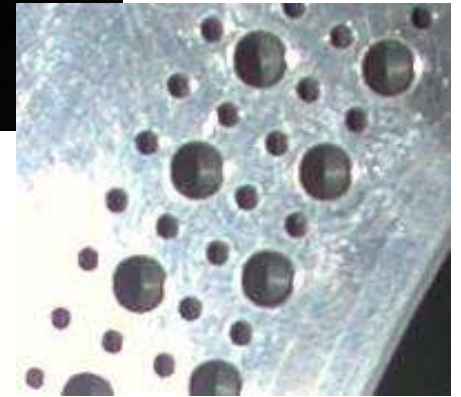
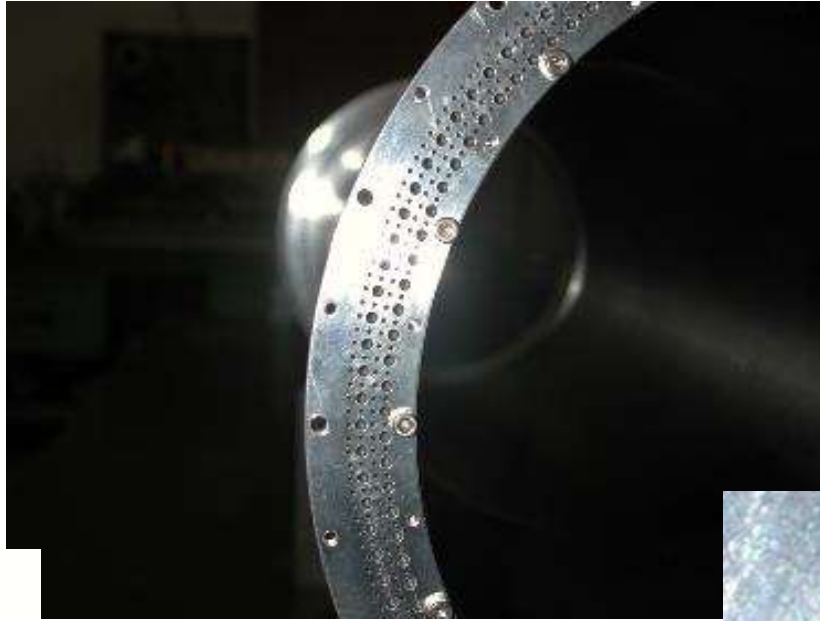

Belle-II CDC small cell chamber

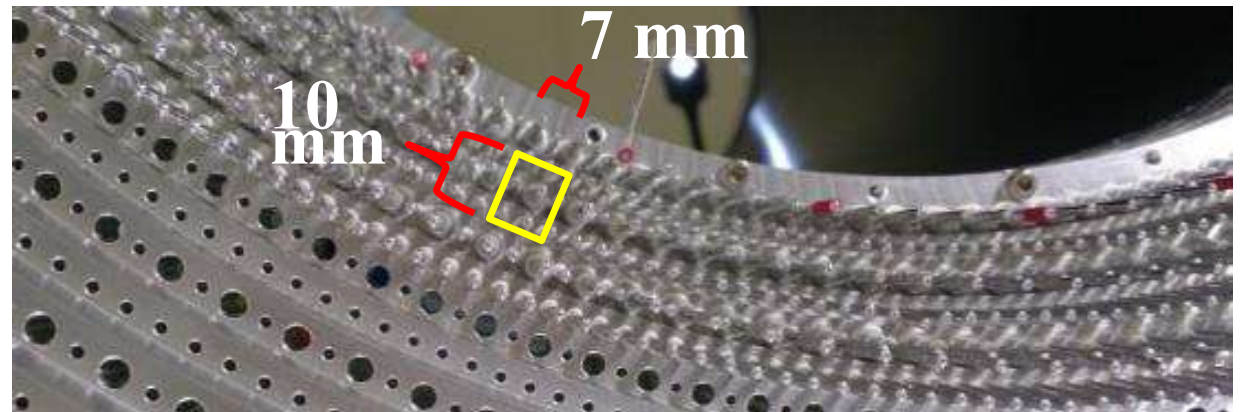
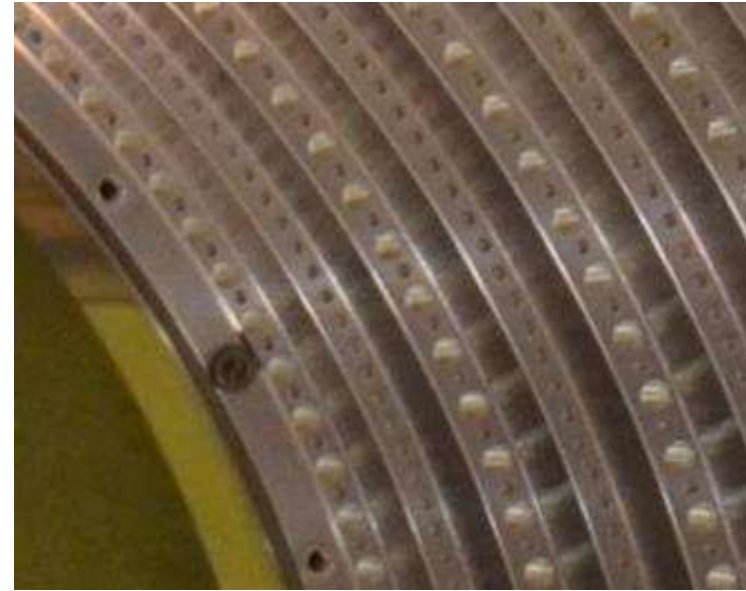

New CDC Gas System

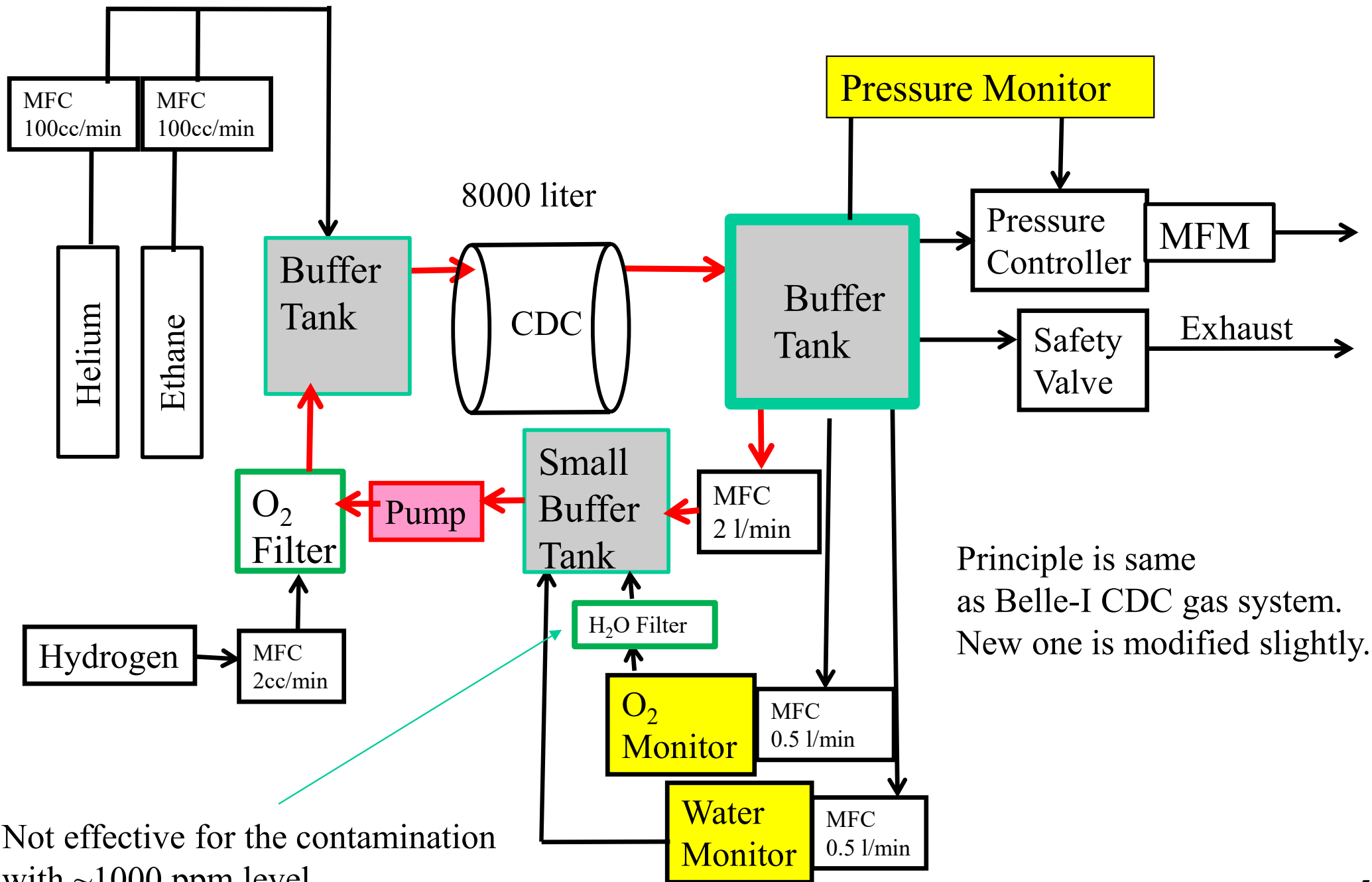

Principle is same as Belle-I CDC gas system. New one is modified slightly.

Not effective for the contamination with ~1000 ppm level

sag calculation

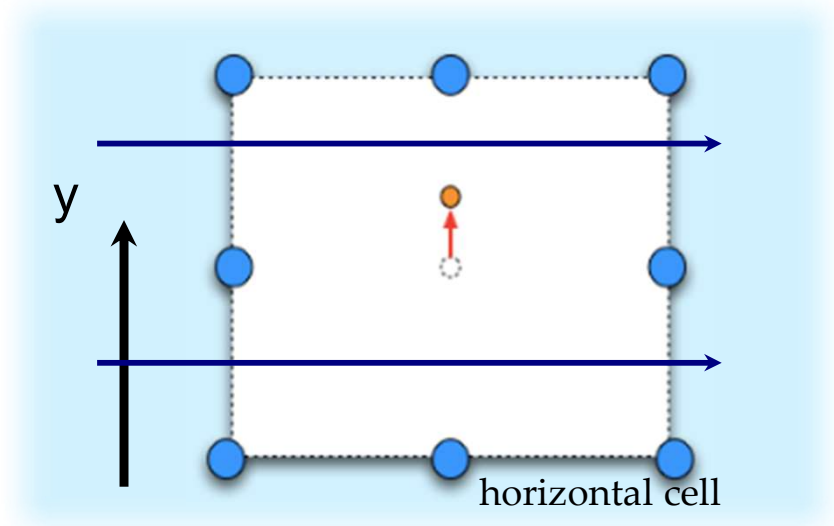

sense wire : 30 μ m, 50gw

tension (total tension)	80g (4.4 ton)	100g (5.2 ton)	120g (6.2 ton)
sag(field) - sag(sense)	84.8 μ m	28.4 μ m	-9.2 μ m

wire length : 2.4 m

current Belle position resolution
 ~ 100 μ m

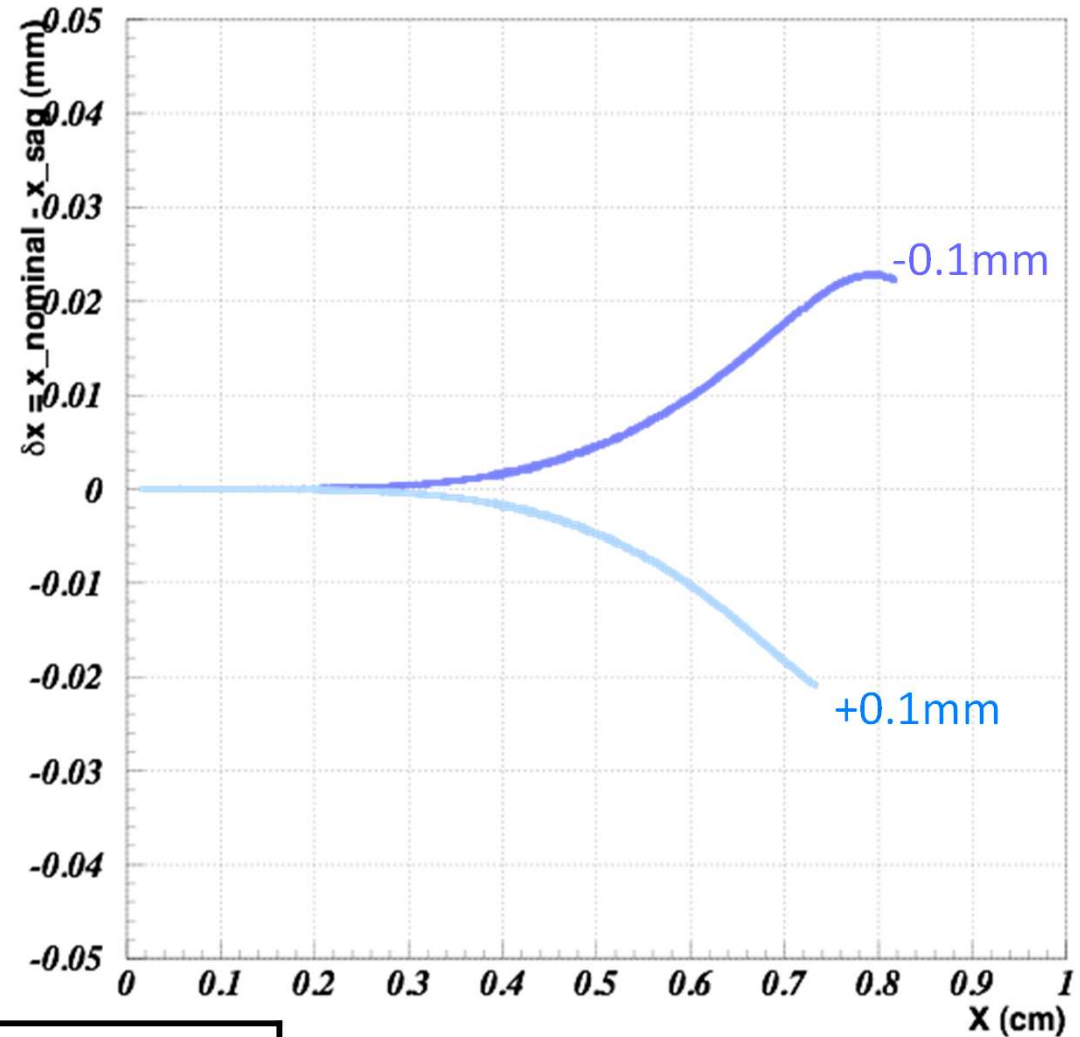

sense wire : 30 μ m, 50gw

tension (total tension)	80g (4.4 ton)
sag(field) - sag(sense)	84.8 μ m

(x: distance from sense wire at nominal case)

← Acceptable

wire tension and gravity sag

* Current Belle CDC

- wire tension is determined to keep the gravity sag of sense and field wire same
- 50gw for sense wire and 120gw for field wire
- total tension = $(50\text{gw} \times 8400) + (120\text{gw} \times 8400 \times 3) = 3.4 \text{ ton}$

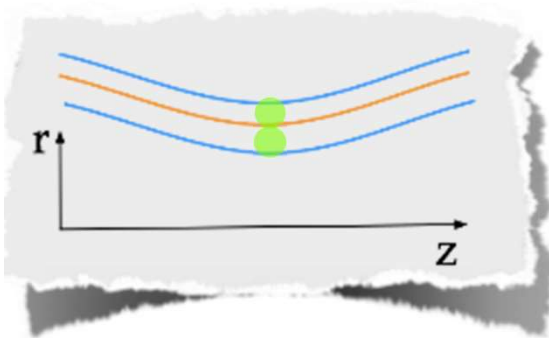

* Belle-II

- number of sense wire: 8400 \rightarrow 14336
- total tension = $(50\text{gw} \times 14336) + (120\text{gw} \times 14336 \times 3) = 6.2 \text{ ton}$ @ same weight
- reduce total tension : 120gw \rightarrow 80gw (base line design) , 6.2 ton \rightarrow 4.4 ton
- however difference of gravity sag is larger

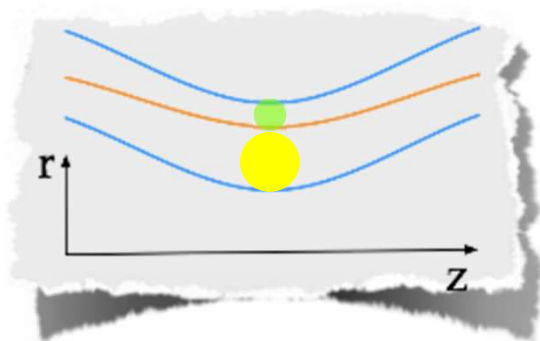

Belle I CDC

Wire chamber (Belle-CDC)

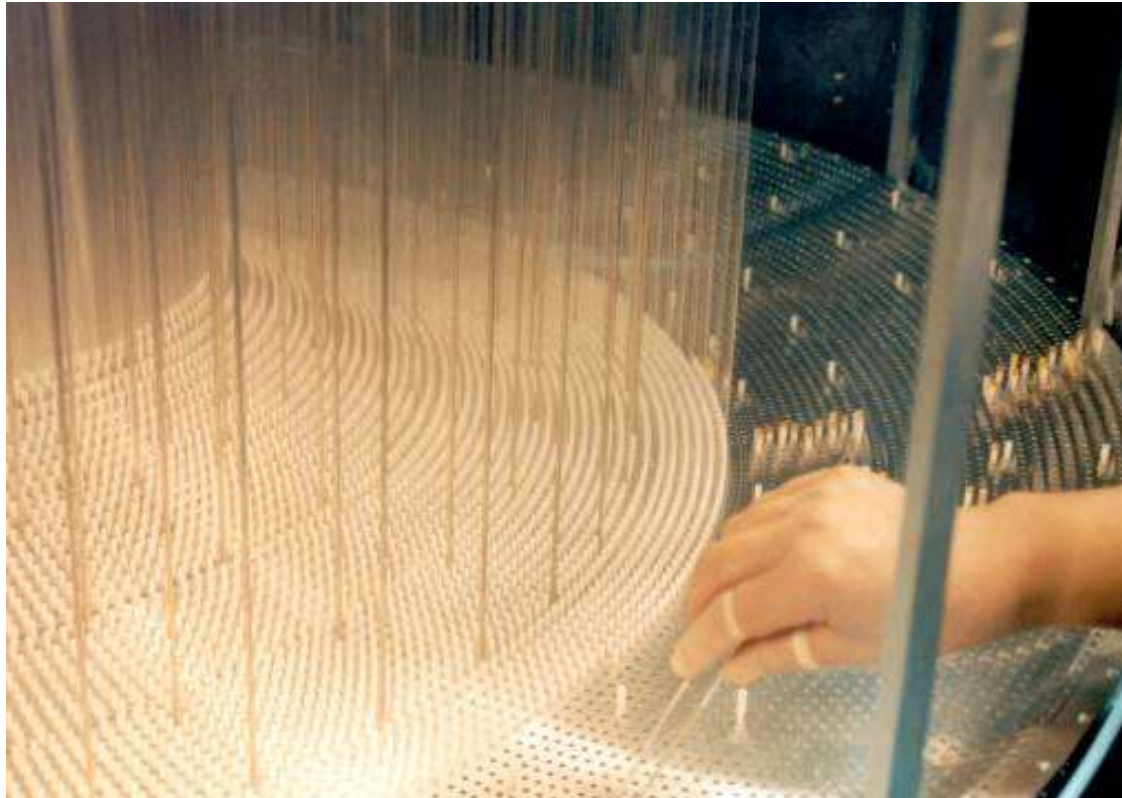

Inside of chamber
During wire stringing



Outside view during electric checking

Structure

- Belle CDC consists of **three parts**(Main, Inner and Cathode).
- Curved Aluminum endplates for the main part.
 - Thickness : 10mm^t
- Conical endplates for the inner part to give a space for accelerator components.

■ 5mm^t CRFP outer cylinder to support whole tension.

■ Two thin CFRP cylinder for cathode readout.

0.4mm^t x 2

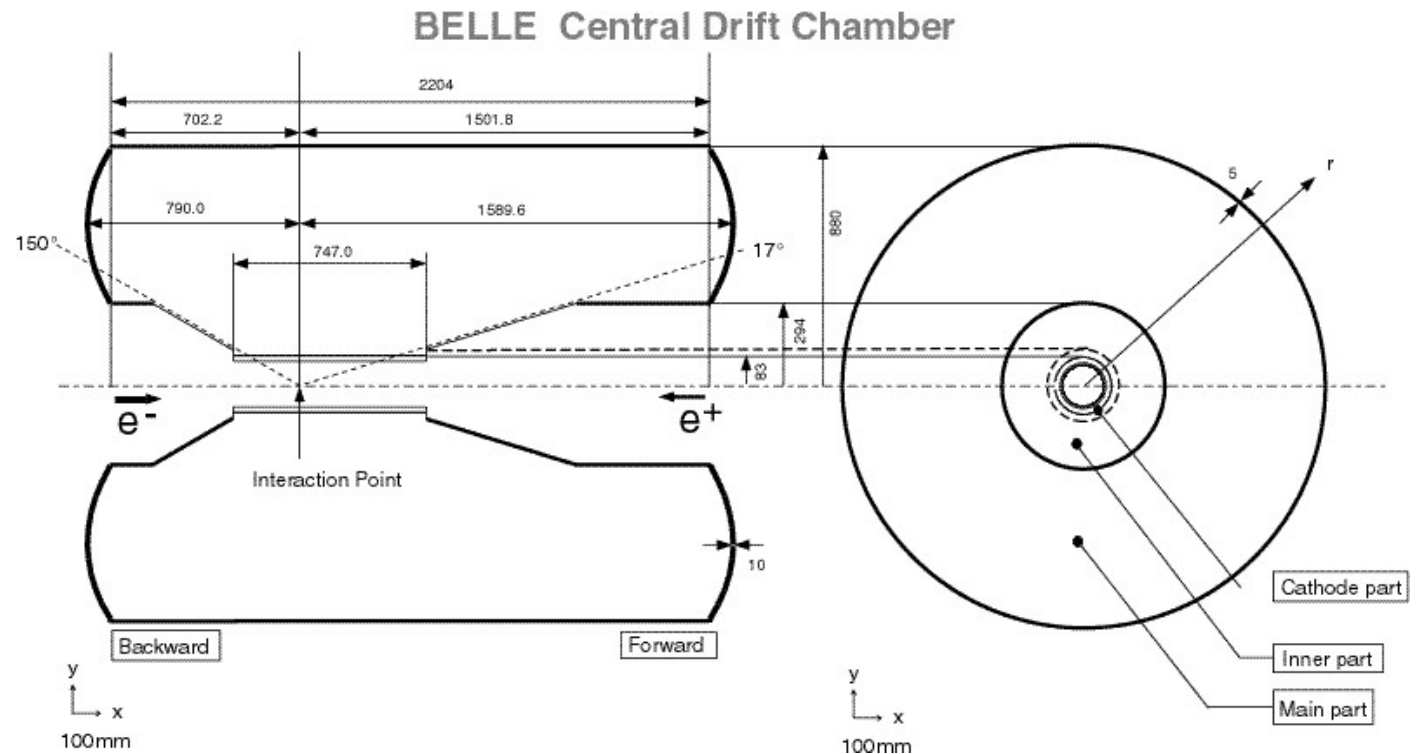

Wire Configuration

- Active region
 - R= 88mm : inner most sense wire
 - R=863mm : outer most sense wire
- Wires
 - $30\mu\text{m}\phi$ Au-W for sense wire
 - $126\mu\text{m}\phi$ Al for field wire
- Square cells
 - 16mm(r)X~18mm(r ϕ)
- 6(axial)+5(stereo) super layers
 - 50 layers in total
- Readout channels
 - 8400 for sense wires
 - 1792 for cathode strips

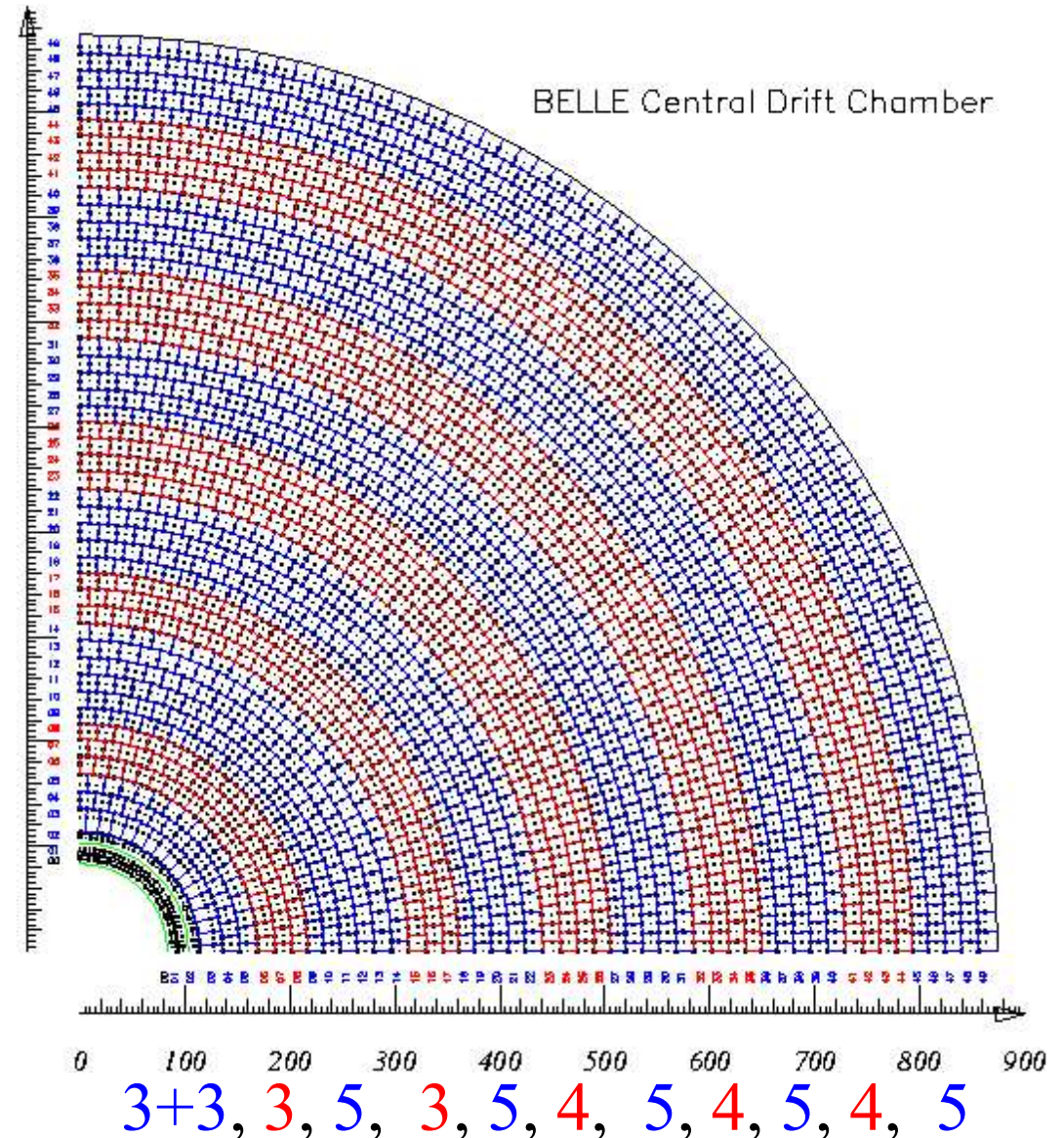

Gas Gain and Drift Velocity

He-C₂H₆(50/50)

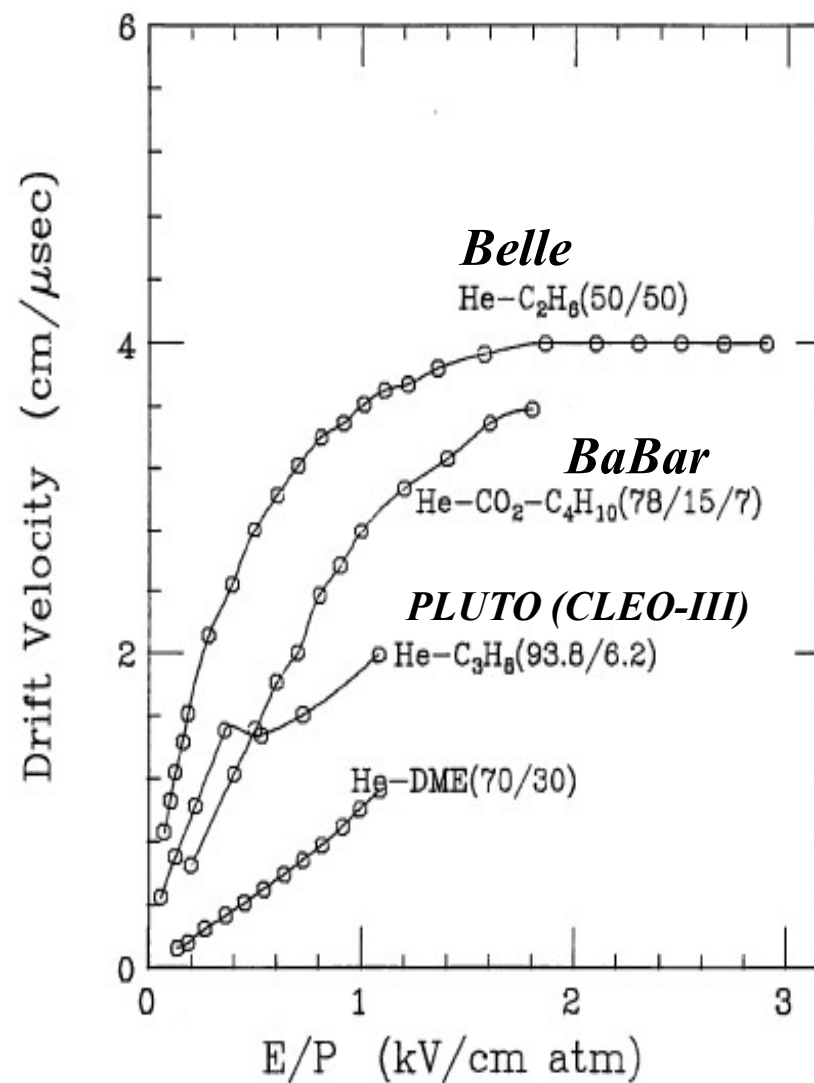
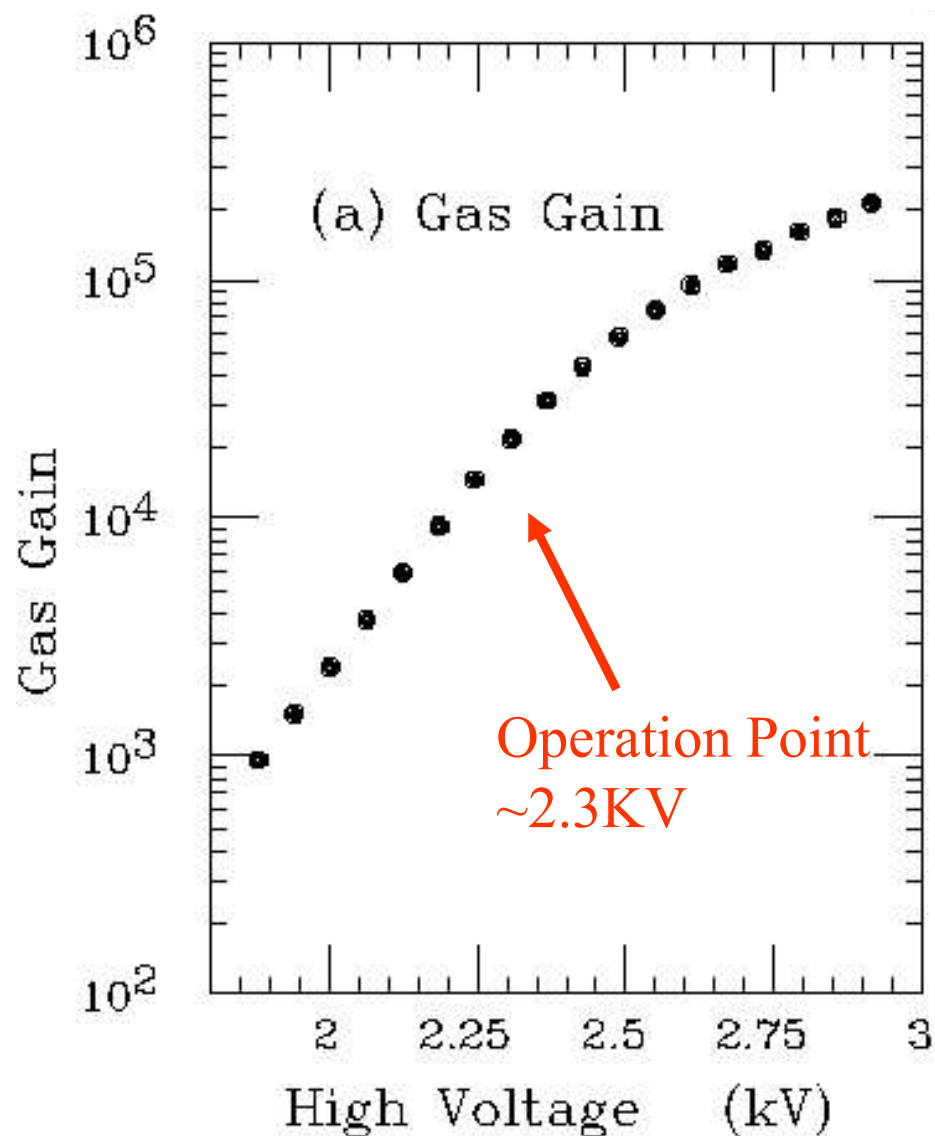

Drift velocity tends to saturate in higher electric field .

XT Curve & Max. Drift Time

Normal cell(17.3mm)

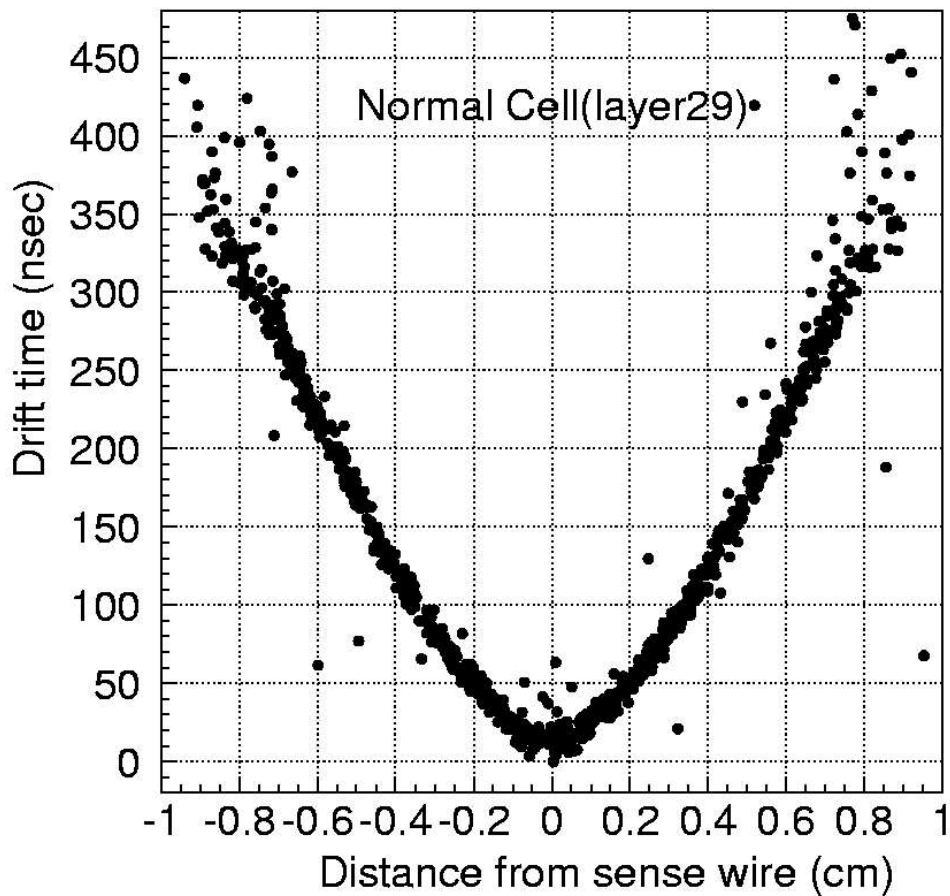

Small cell(5.4mm)

