

Heavy Flavor Production at LHCb

张艳席



第一届中国电子离子对撞机相关物理年会
2026/04/19-22

Dedicated to heavy flavor physics

Run 1-2 detector, $L_{\text{int}} = 4 \times 10^{32} \text{ cm}^{-2} \text{ s}^{-1}$

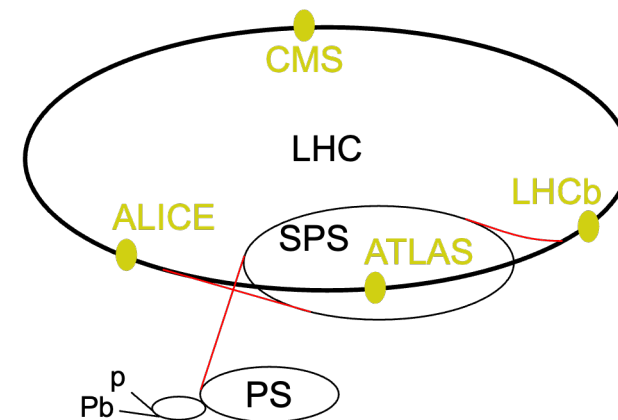
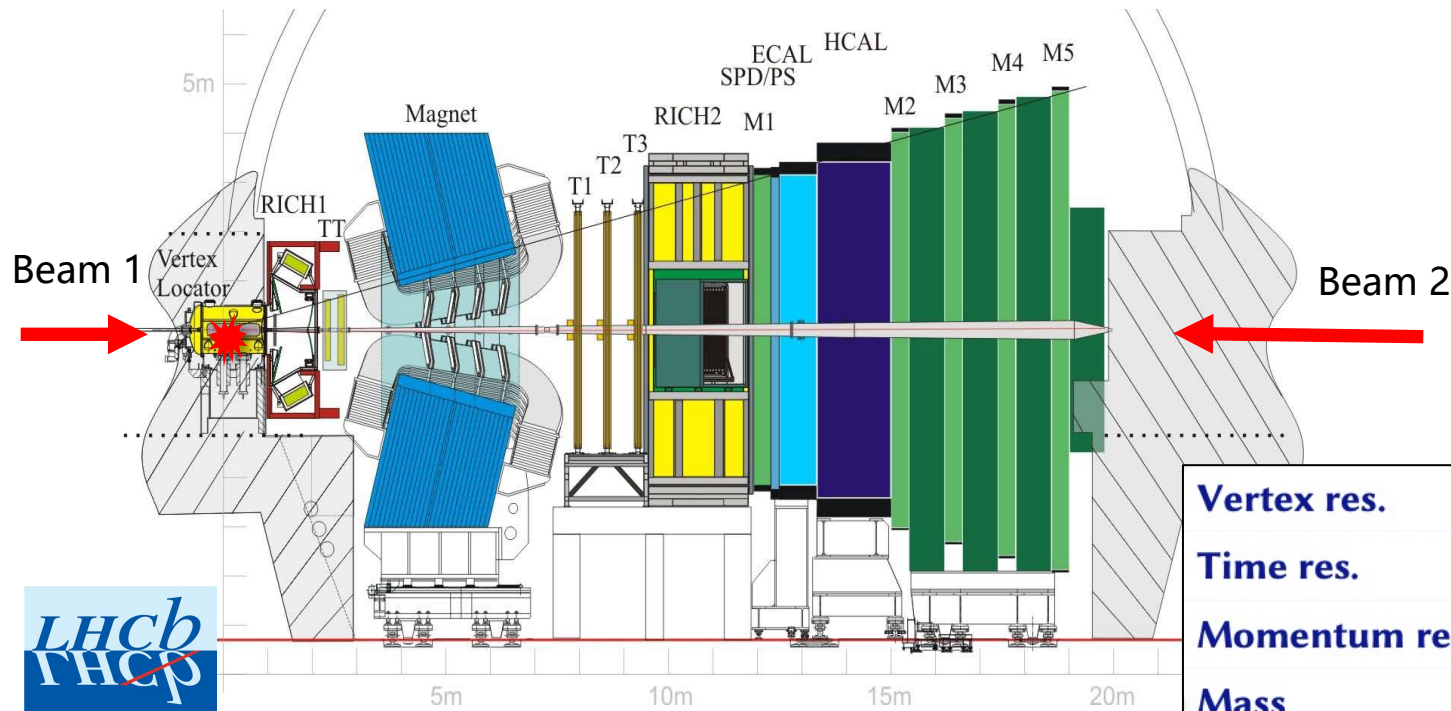

Key Performances

Vertex res.	$\sigma_{\text{IP}} = 20 \mu\text{m}$
Time res.	$\sigma_{\tau} = 45 \text{ fs}$ for $B_s^0 \rightarrow J/\psi\phi$ or $D_s^+ \pi^-$
Momentum res.	$\Delta p/p = 0.4 \sim 0.6\%$ (5 – 100 GeV/c)
Mass	$\sigma_m = 8 \text{ MeV}/c^2$ for $B \rightarrow J/\psi X$
Hadron ID	$\varepsilon(K \rightarrow K) \sim 95\%$ mis-ID $\varepsilon(\pi \rightarrow K) \sim 5\%$
Muon ID	$\varepsilon(\mu \rightarrow \mu) \sim 97\%$ mis-ID $\varepsilon(\pi \rightarrow \mu) \sim 1 - 3\%$
ECAL res.	$\Delta E/E = 1\% \oplus 10\%/\sqrt{E \text{ (GeV)}}$

JINST 3 (2008) S08005

Int. J. Mod. Phys. A 30 (2015) 1530022

Upgrade I

Run 3 detector, $L_{\text{int}} = 2 \times 10^{33} \text{ cm}^{-2}\text{s}^{-1}$

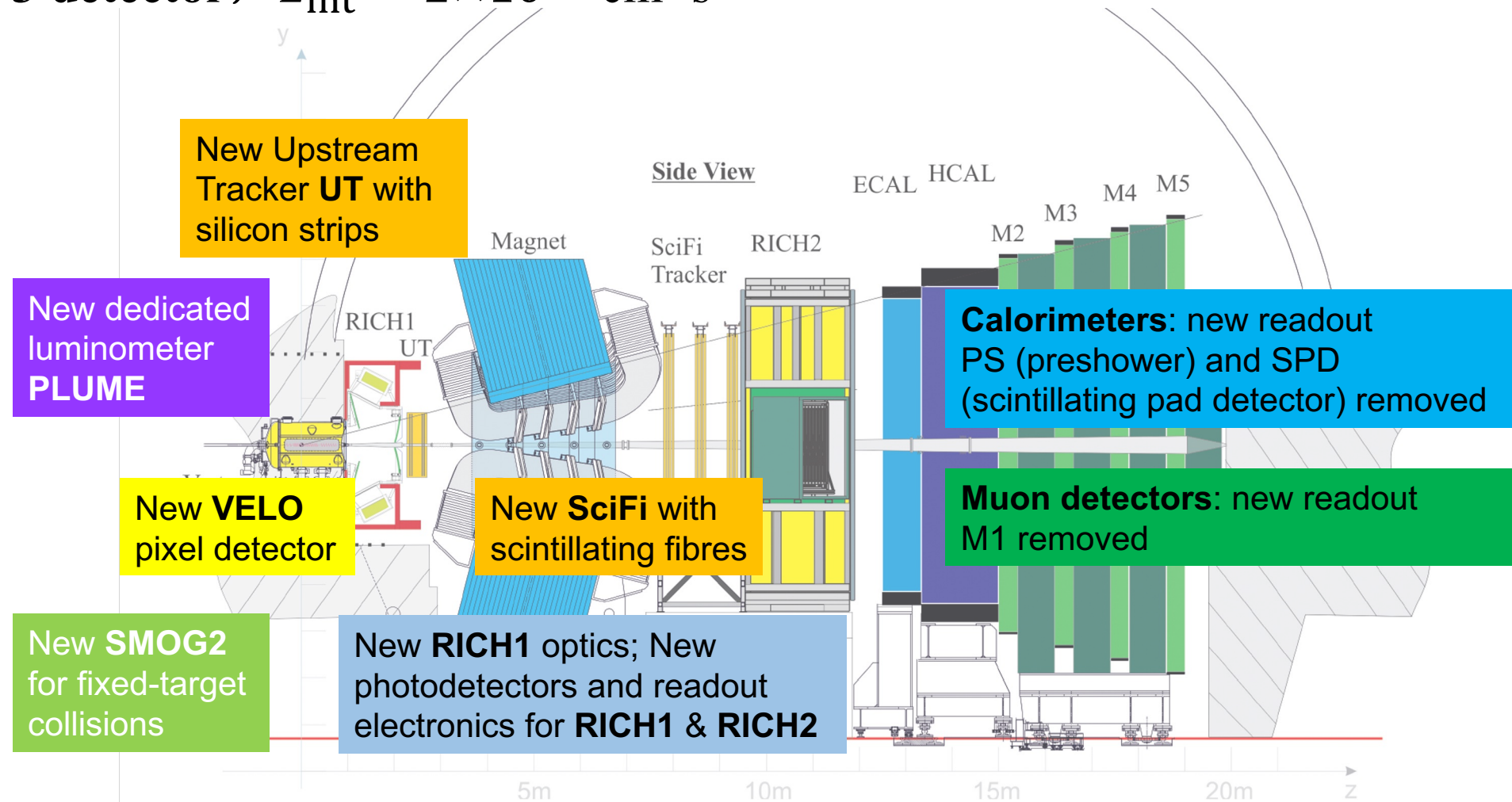

Unique kinematic coverage

Both colliding modes and fixed-target modes

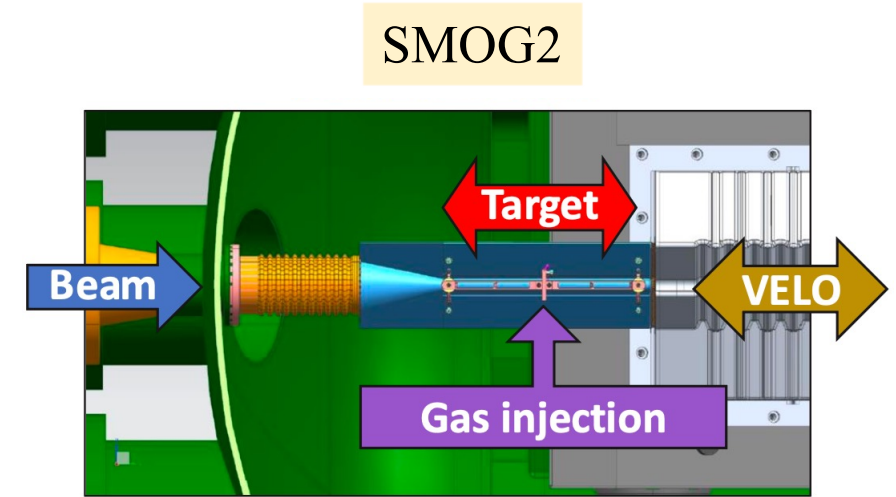
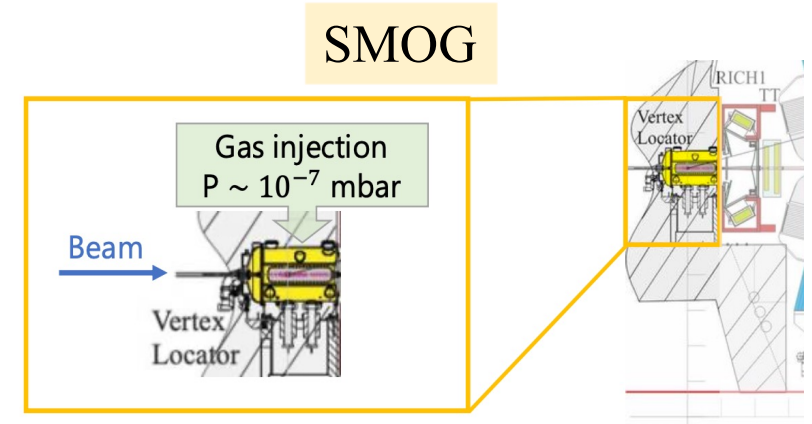
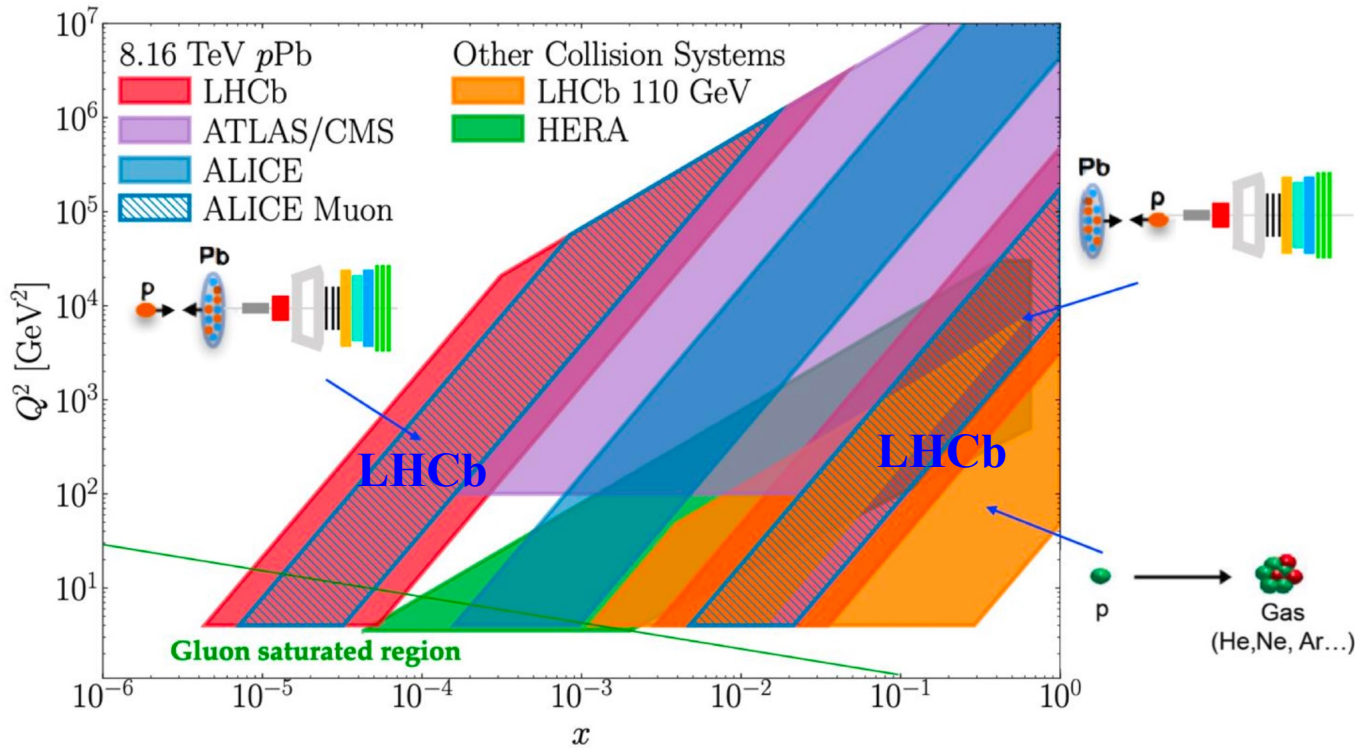

LHCb data

- pp collisions at 7 ~ 13.6 TeV, $\int \mathcal{L} = 35 \text{ fb}^{-1}$
- Heavy ion data
 - Colliding: $p\text{Pb}$, PbPb , XeXe , OO , NeNe
 - Fixed-target: $p\text{H}_2$, $p\text{He}$, ..., $p\text{Ar}$, PbNe , PbAr

$$\sigma(pp \rightarrow b\bar{b}X, 13 \text{ TeV}) \approx 0.5 \text{ mb}$$

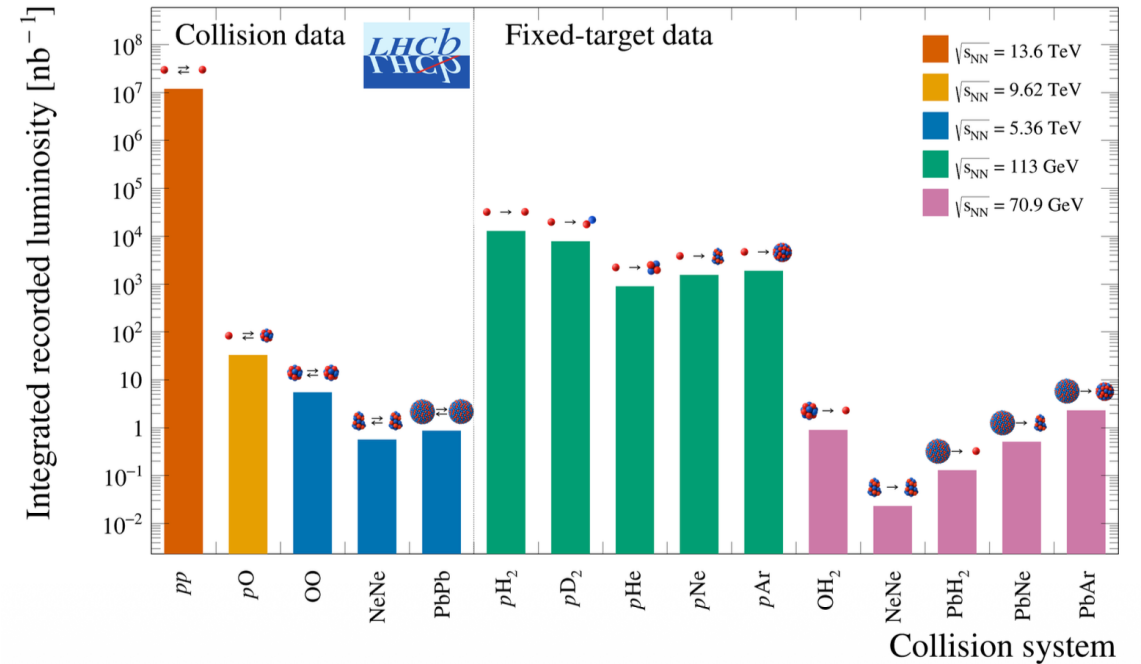
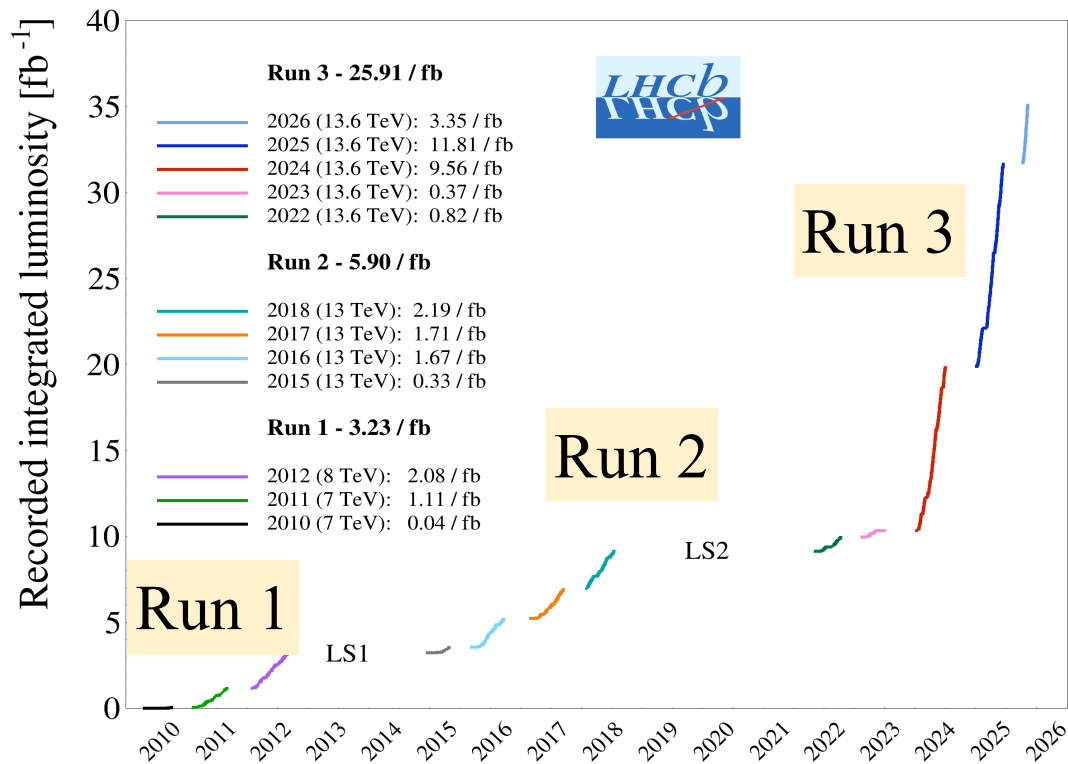

Heavy flavor hadroproduction

- QCD factorization

- Parton distribution function (PDF)
- Perturbation expansion: large quark mass sets a hard scale
- Hadronization

$$\sigma(Q) \propto f(x_1, \mu_F^2) \times f(x_2, \mu_F^2) \otimes d\sigma(x_1, x_2 \rightarrow Q + X, \mu_F^2, \mu_R^2) \otimes D(Q \rightarrow H_Q)$$

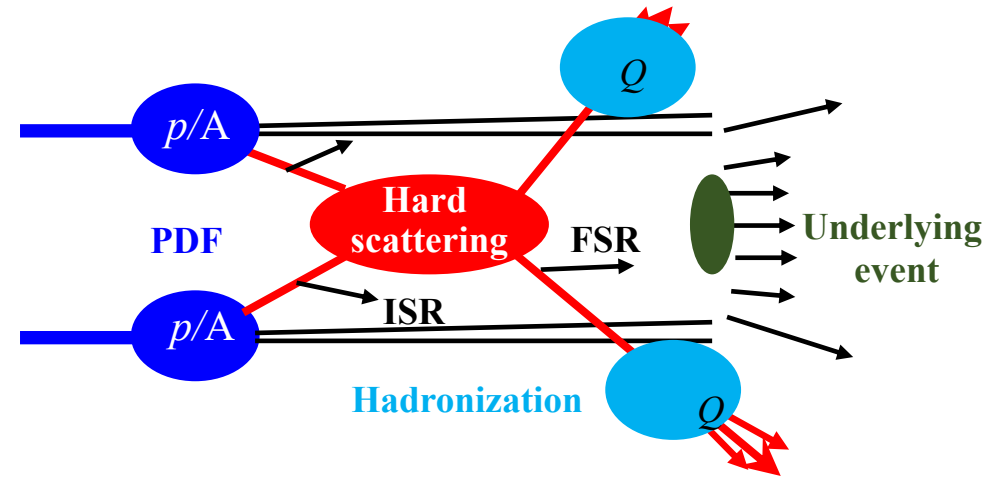

- Physics relevant

- Test of pQCD approach
- Hadron structure
- QCD medium tomography (heavy ion physics)
- Key inputs for other measurements: relative rates, asymmetry ...

Open heavy flavor production in pp collisions

- Differential cross-section in good agreement with p QCD

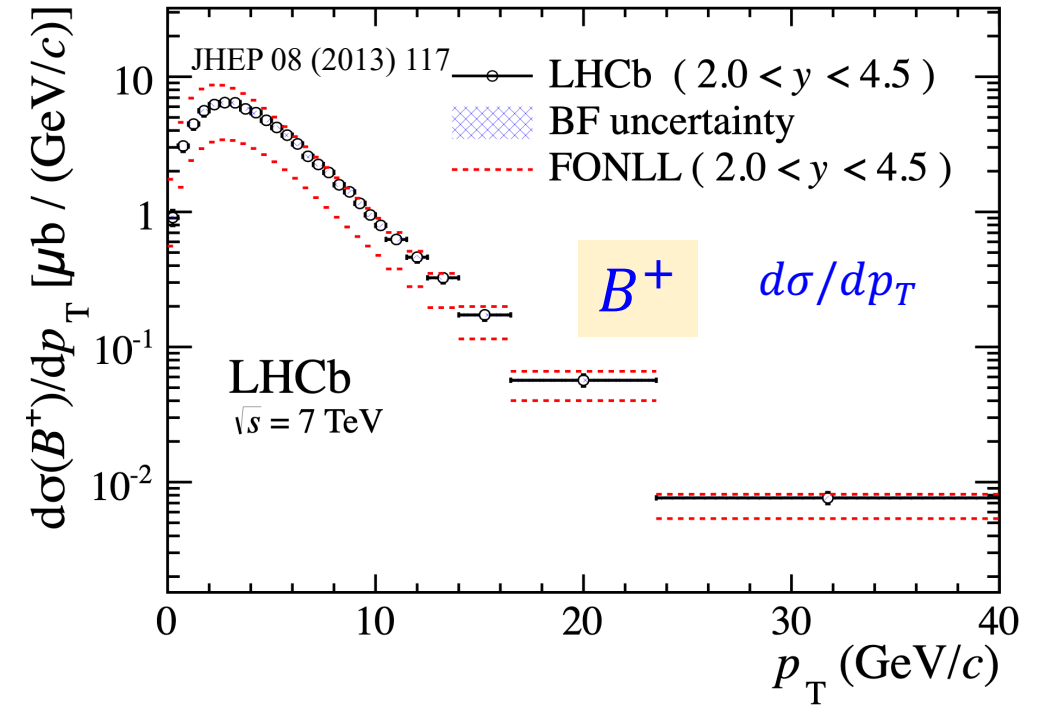
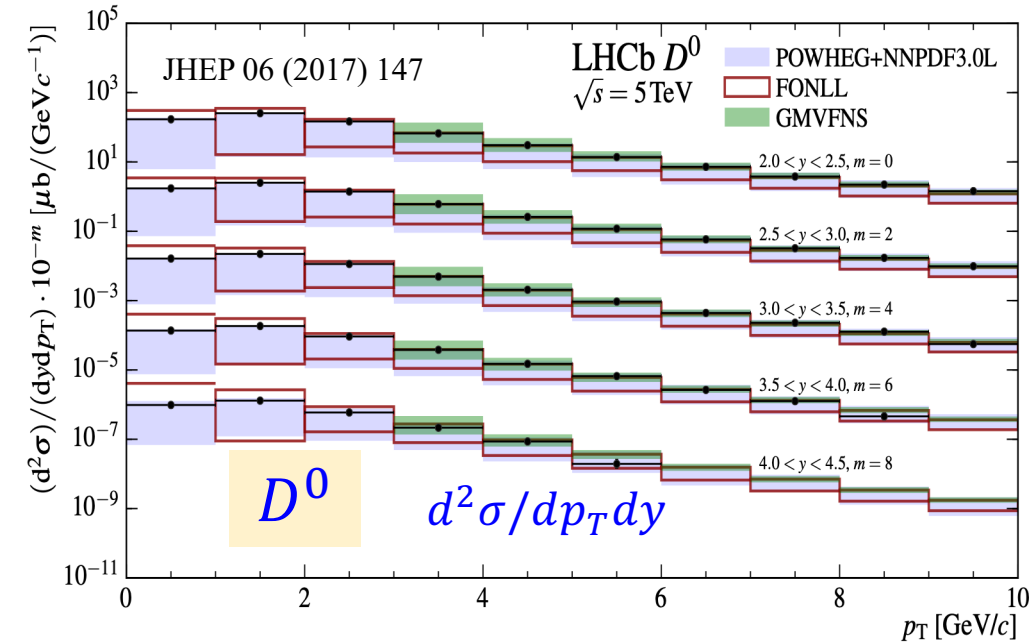

Theoretical uncertainties: scales and PDF

Constrain gluon PDF

- Significantly improve PDF precision at low- x

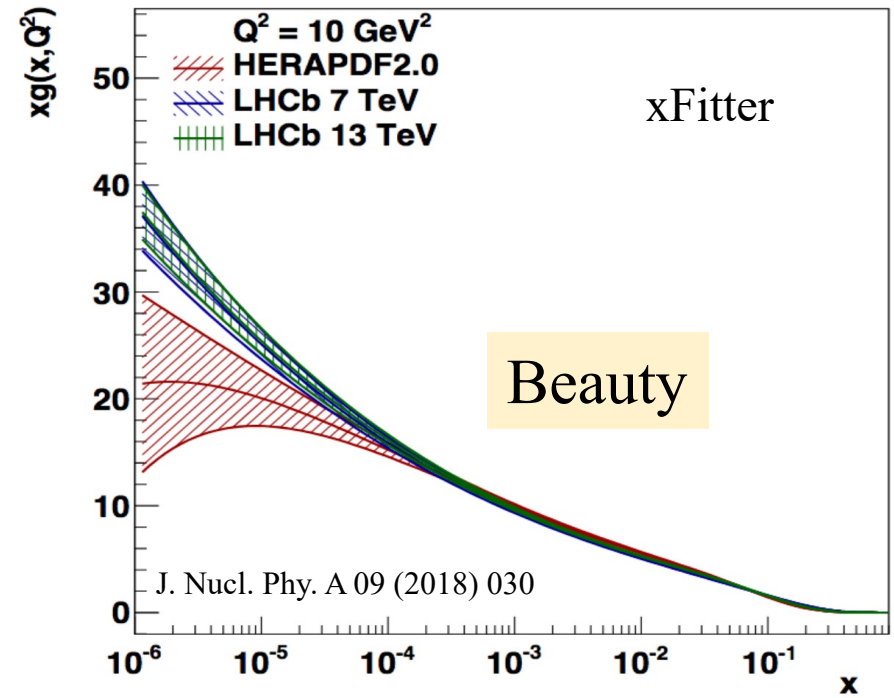
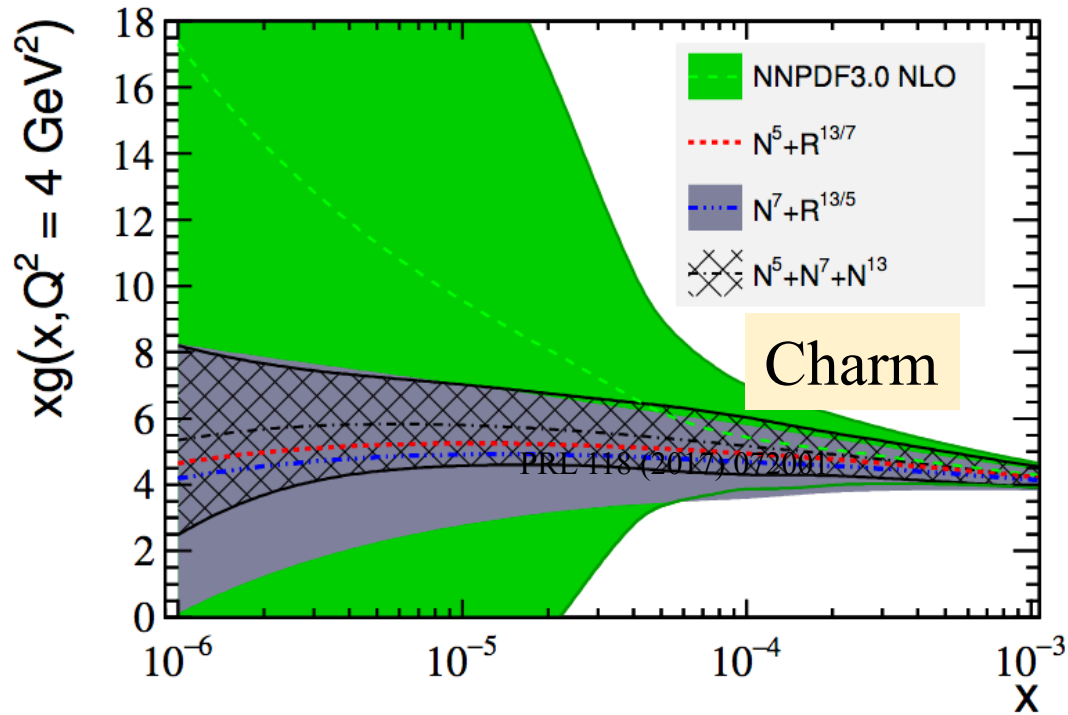

Hadronization

- Heavy quark (theory) \Leftrightarrow Heavy hadron (experiment)
- Universality of heavy quark fragmentation?
- Baryon-to-meson ratios decrease with p_T , compatible with LEP data at high p_T
- Meson-to-meson or baryon-to-baryon ratio only weakly depends on p_T

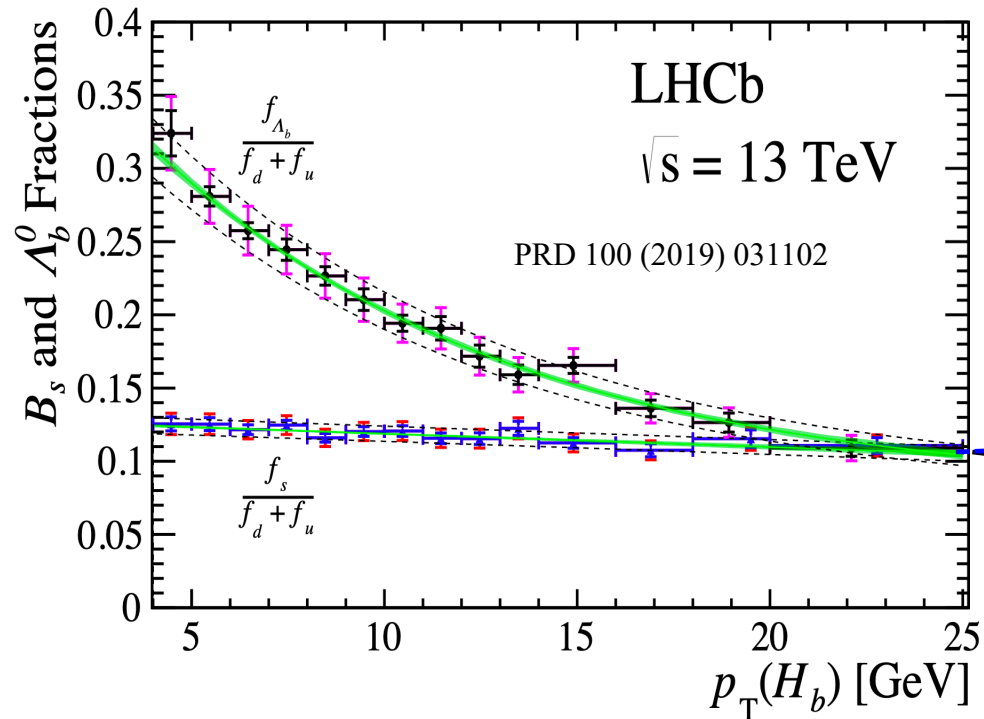

$\frac{f_s}{f_d+f_u}$: ratio between B_s^0 and $B_{u,d}$

$\frac{f_{\Lambda_b}}{f_d+f_u}$: ratio between Λ_b^0 and $B_{u,d}$

Heavy quarkonium production

- Sensitive to both perturbative and non-perturbative QCD
- Differential cross-section described by NRQCD at high- p_T (LDMEs from Tevatron)
- Weak polarization, disfavoring CSM and NRQCD \rightarrow remains a puzzle !

No coherent description of heavy quarkonium production

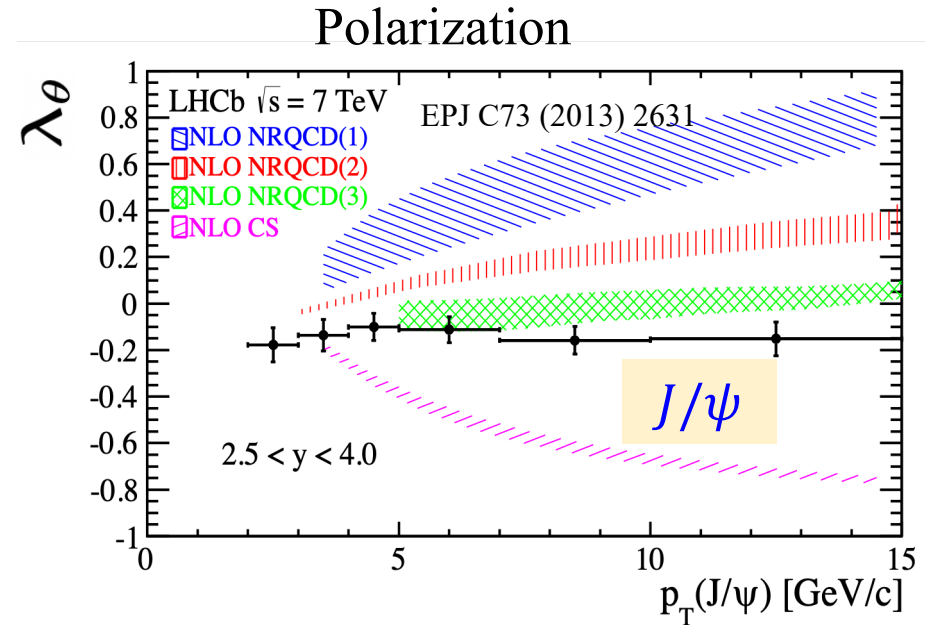
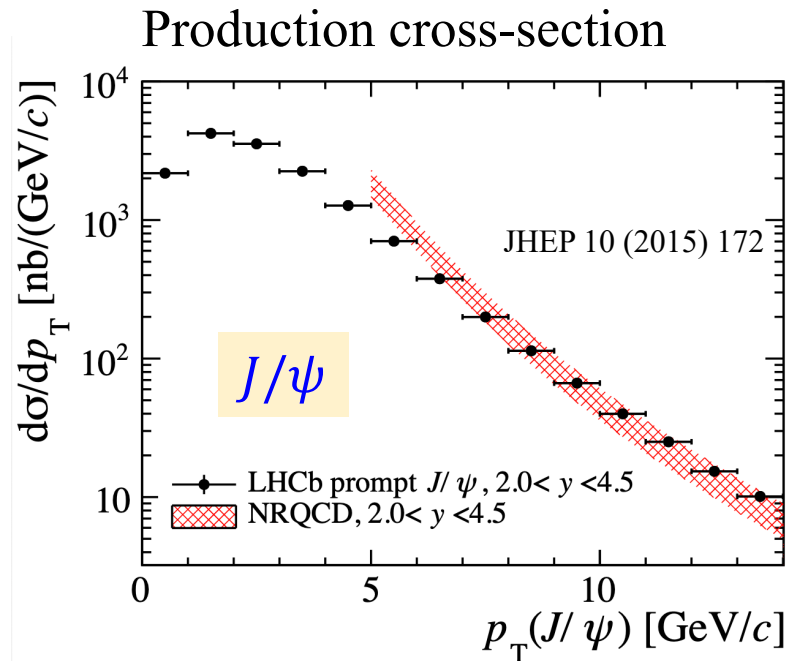

Quarkonium production with multiplicity

- Ratio of quarkonium cross-section sensitive to nuclear matter
- Excited state suppressed than lower state at high multiplicity
 - Similar trend for for pp and pPb
 - Less suppression for Pbp and $PbPb$ in common multiplicity range

Effects of comovers and beyond?

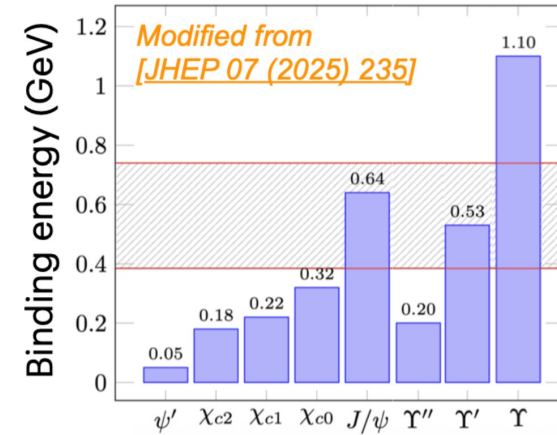
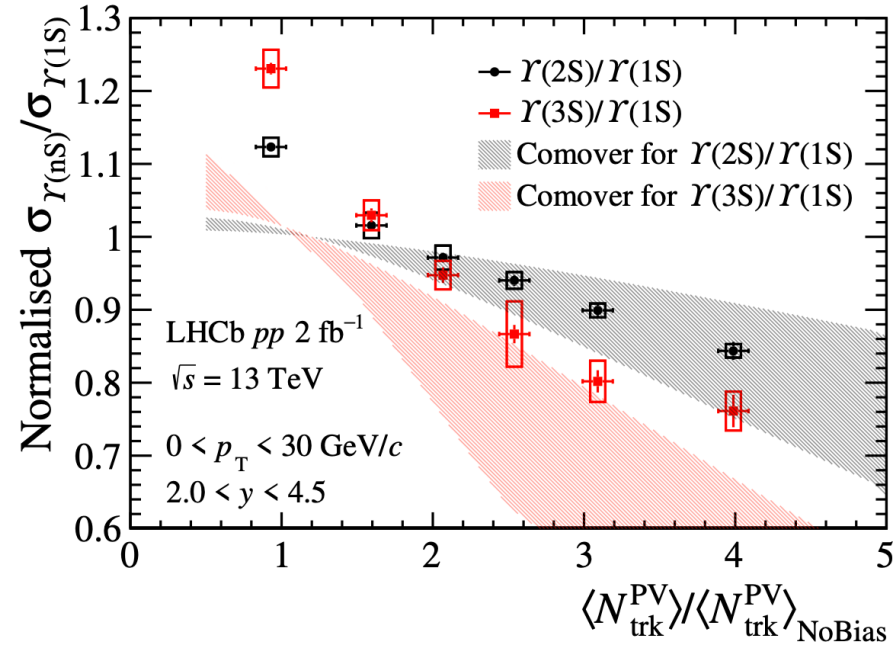
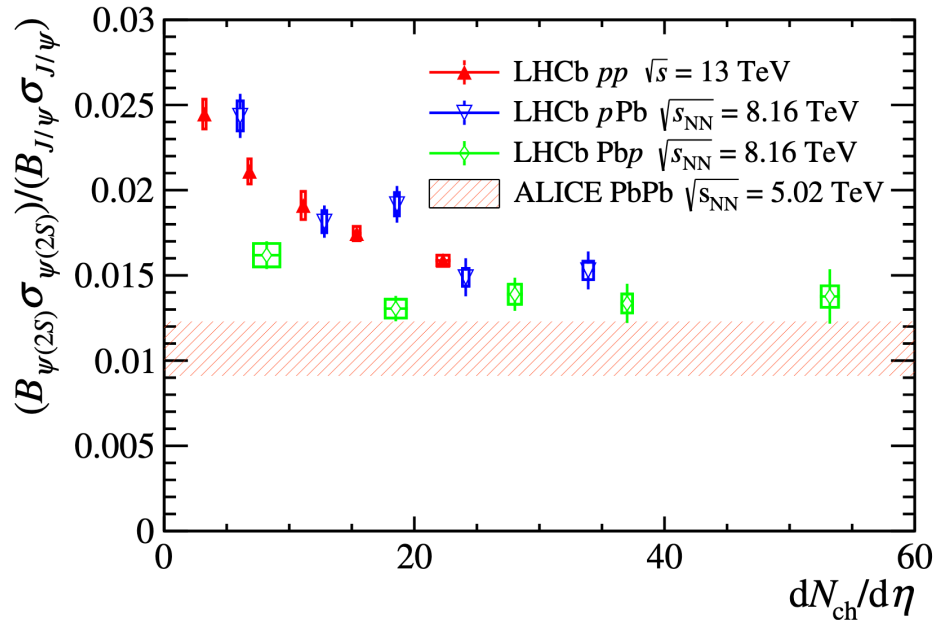

JHEP05(2024)243, JHEP05(2025)011, JHEP11(2025)169

Charm production in heavy ion data

- D^0 production in $p\text{Pb}$ data sensitive to gluon PDF in Pb nucleus

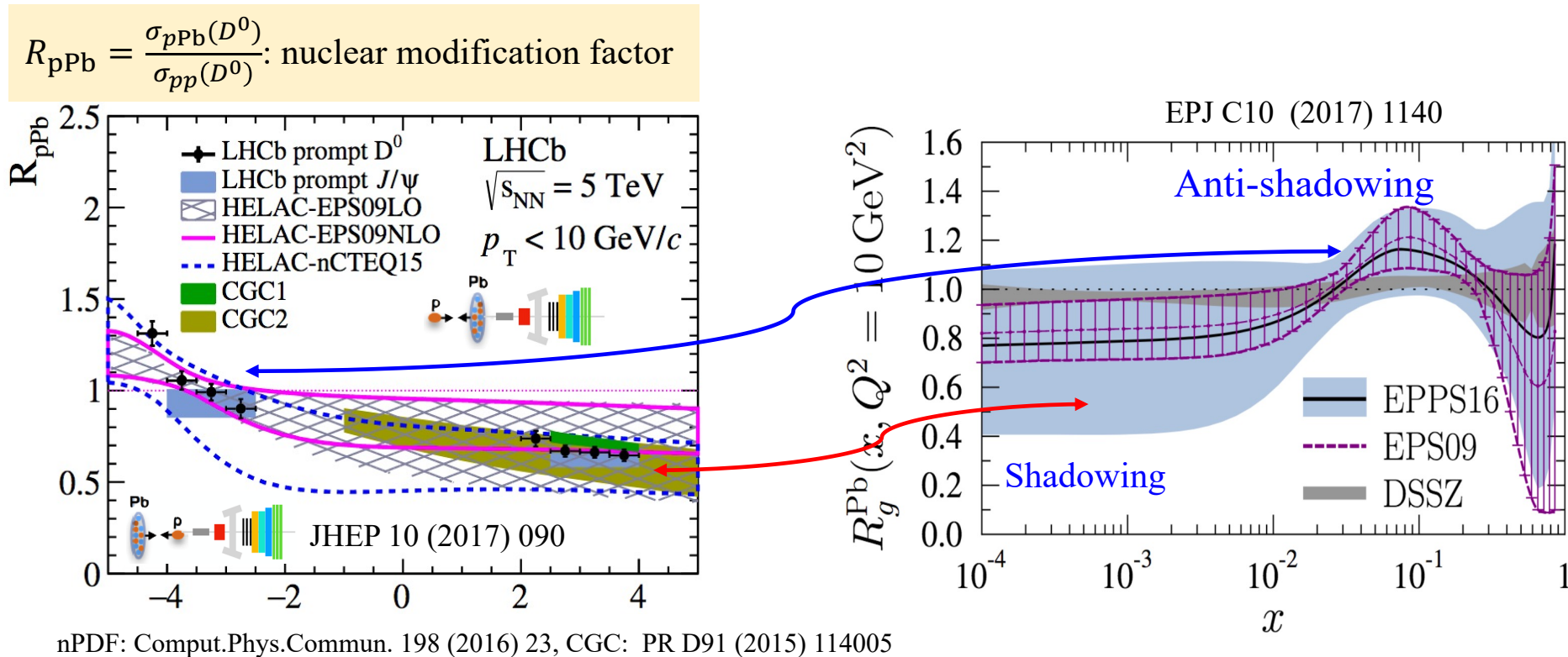

- $R_{p\text{Pb}}(y)$ pattern and magnitude consistent with modification in nPDF
 - Strong suppression ($\sim 30\%$) of gluon PDF at small- x (positive y)
 - Compatible with no suppression and hint of enhancement at large- x (negative y)

Enhancement of double parton scattering (DPS)

- DPS production enhanced in heavy ion collisions
 - pA collision: $\sim A \times (1 + A^{1/3}/\pi) \approx 3A$ for pPb , more than scaling by mass number A
 - Doubly sensitive to gluon PDF
- DPS studied by like-sign DD production, enhancement confirmed by LHCb data
 - Interplay between geometric enchantment and gluon PDF modification

Double parton scattering

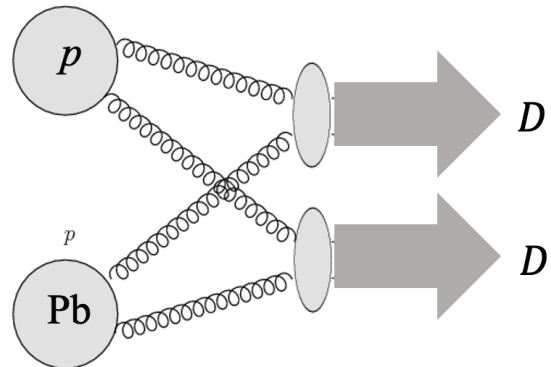

Geometric enchantment

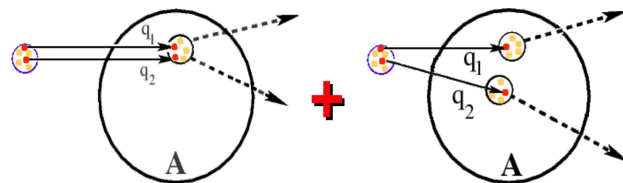

$$\sigma_{(pA)}^{\text{DPS}} = \sigma_{(pA)}^{\text{DPS},1} + \sigma_{(pA)}^{\text{DPS},2}$$

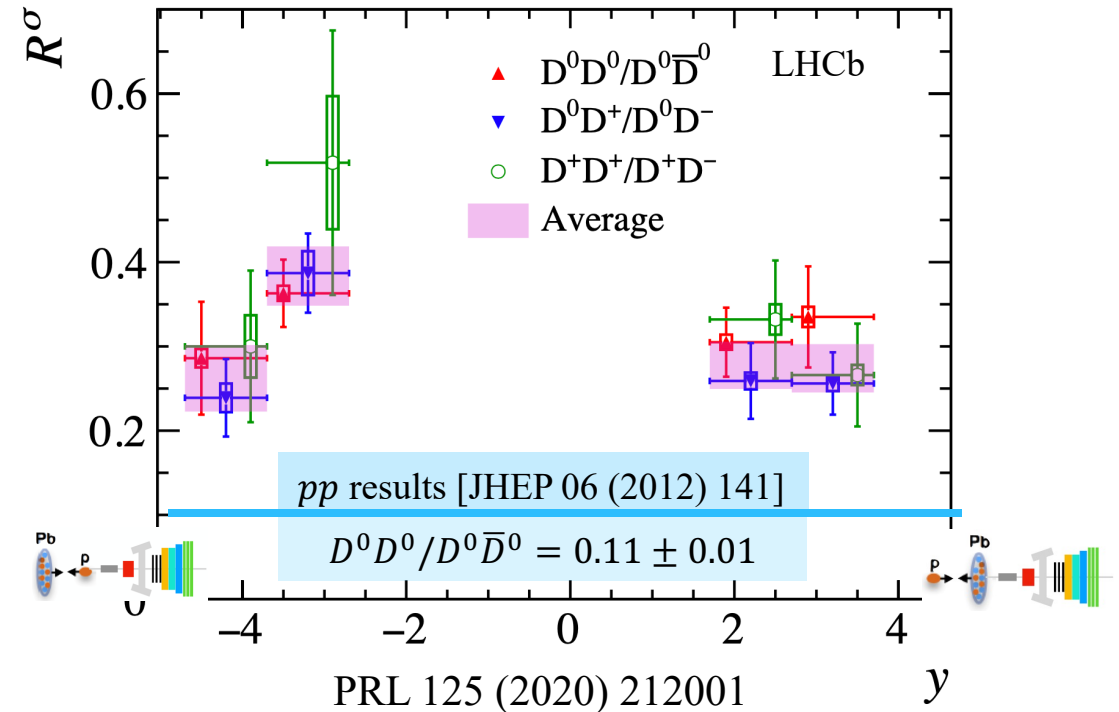

- First measurements in NeNe and OO collisions
- Ratio of p_T -differential cross-sections between NeNe and OO
 - Overall normalization similar to pQCD, but different trend
 - Qualitatively consistent with QGP

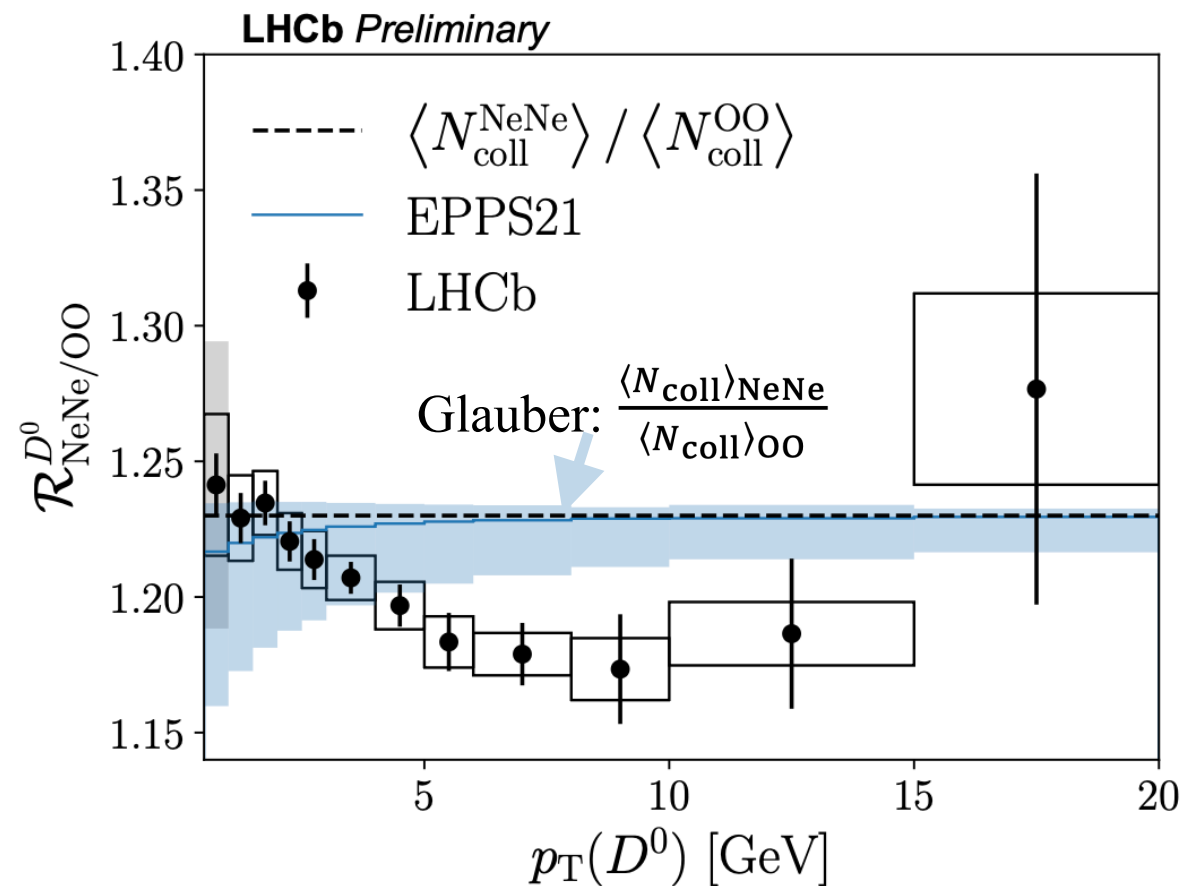
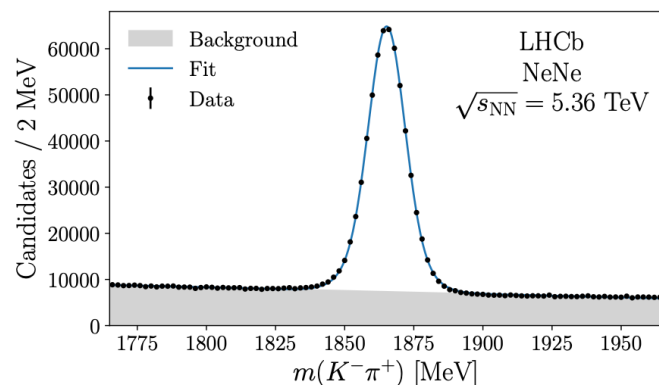
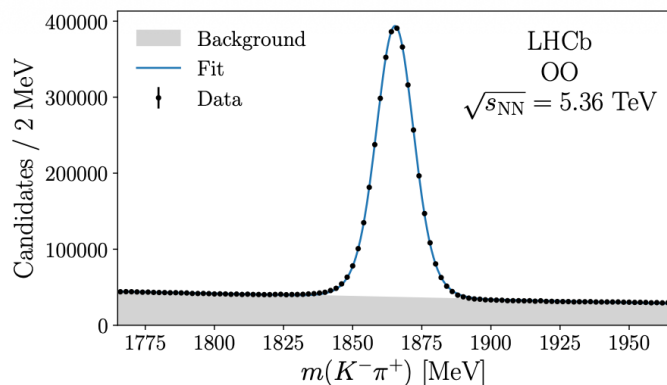

Charm production in fixed-target collisions

- Probes large- x , sensitive to intrinsic charm (IC) and valence quarks
- Differential cross-section of D^0 consistent with pQCD
- Asymmetry between $D^0(c\bar{u})$ and $\bar{D}^0(\bar{c}u)$ at very forward
 - Trend consistent with IC
 - Data explained by IC + recombination [PLB835(2022)137530]

To be followed: $D_S^\pm, \Lambda_C^\pm \dots$

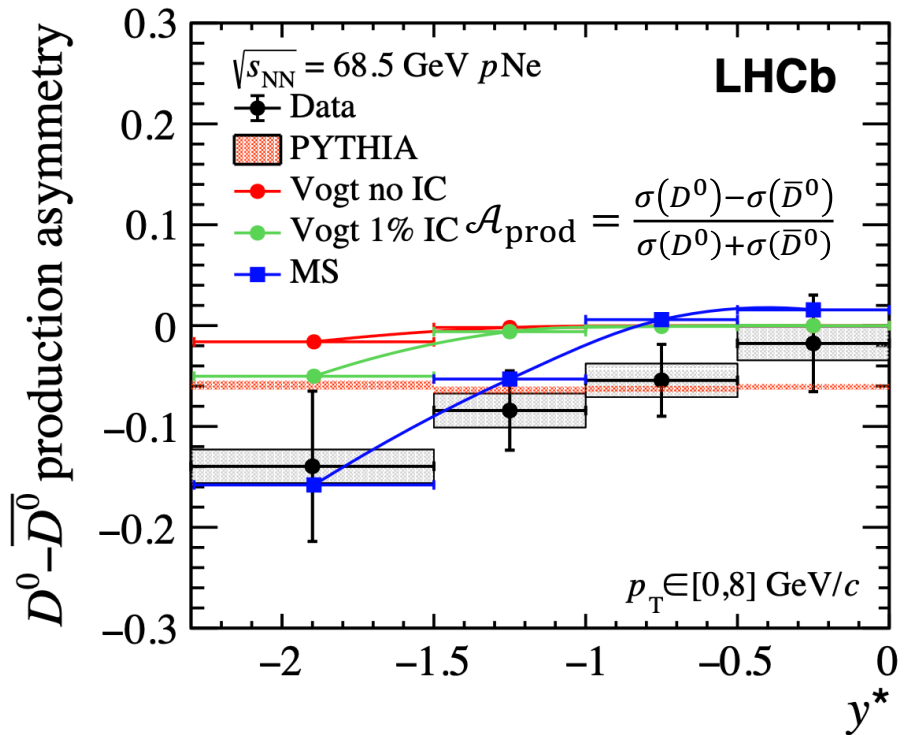
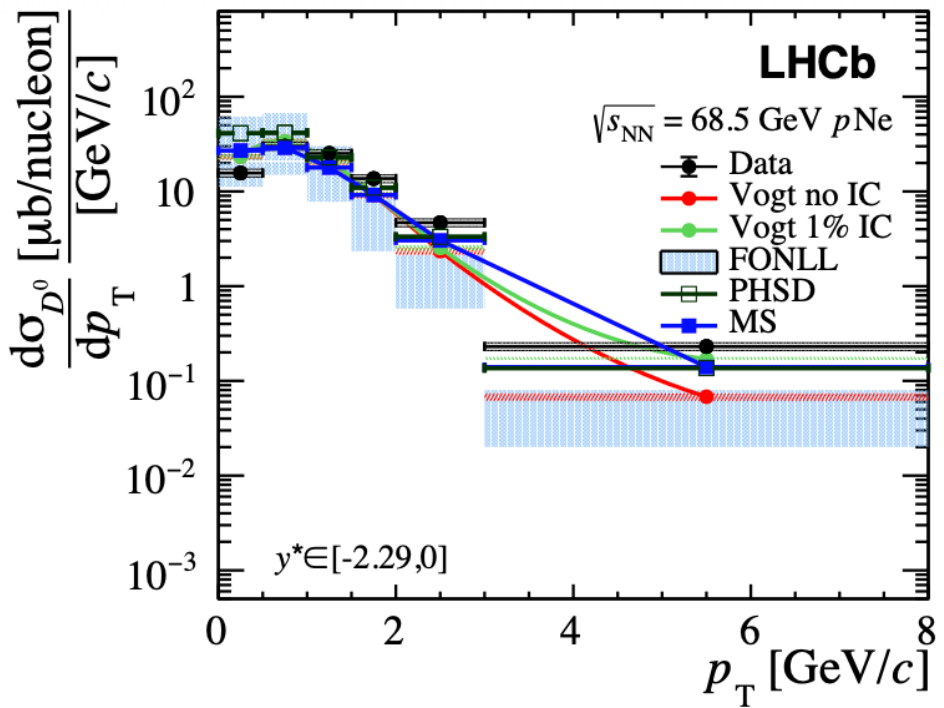

$\Lambda_{(c)}$ polarization in fixed-target (pNe $\sqrt{s} = 68$ GeV)

- Polarization unique probe for spin dependent physics and nonperturbative QCD
- Λ baryon: strong transverse polarization at high x_F , LHCb data on trend
- Λ_c^+ baryon: hint of transverse polarization

Z.-T. Liang, X.-N. Wang, PRL 94 (2005) 102301...

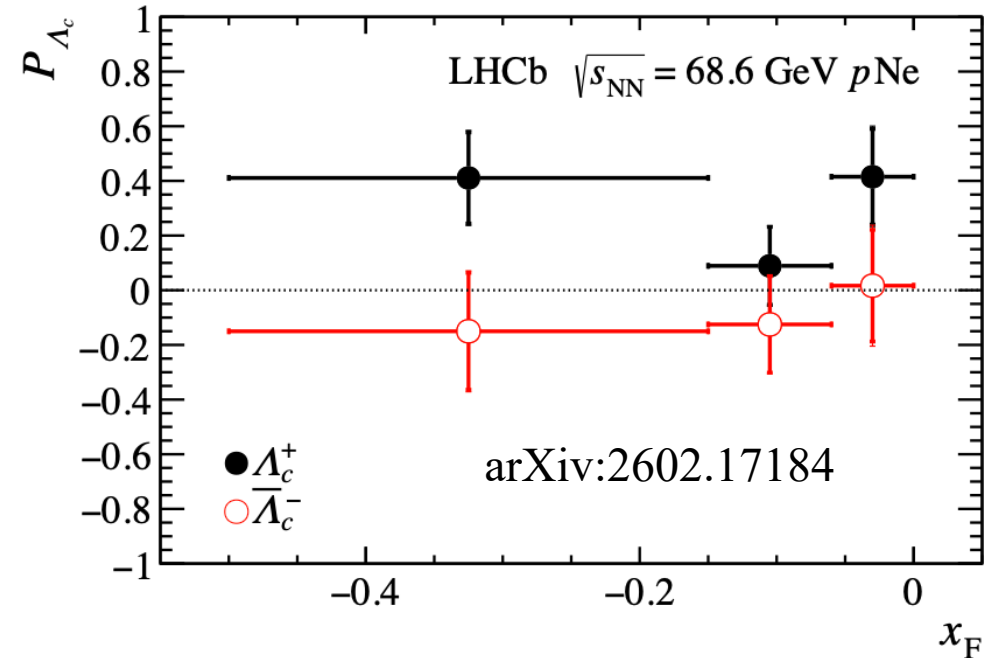
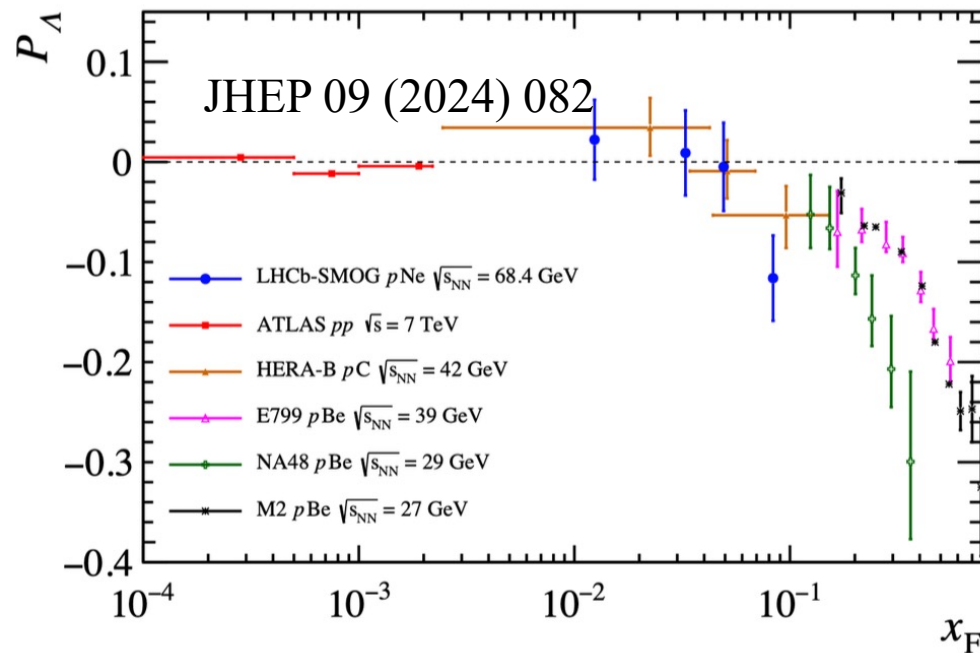

Summary and outlook

- Broad and unique program of nuclear structure and QCD with heavy flavor at LHCb
 - pp , heavy ion collisions and fixed-target data
 - Open heavy flavor production: (nuclear) PDF, pQCD calculations, hadronization
 - Heavy quarkonium: polarization puzzle, suppression of excited states at high multiplicity
 - Heavy ion collisions: enhanced double parton scattering, hot nuclear matter
 - Fixed target data: nuclear structure, polarization, valence quarks
- Outlook: long term plans and unique collision systems

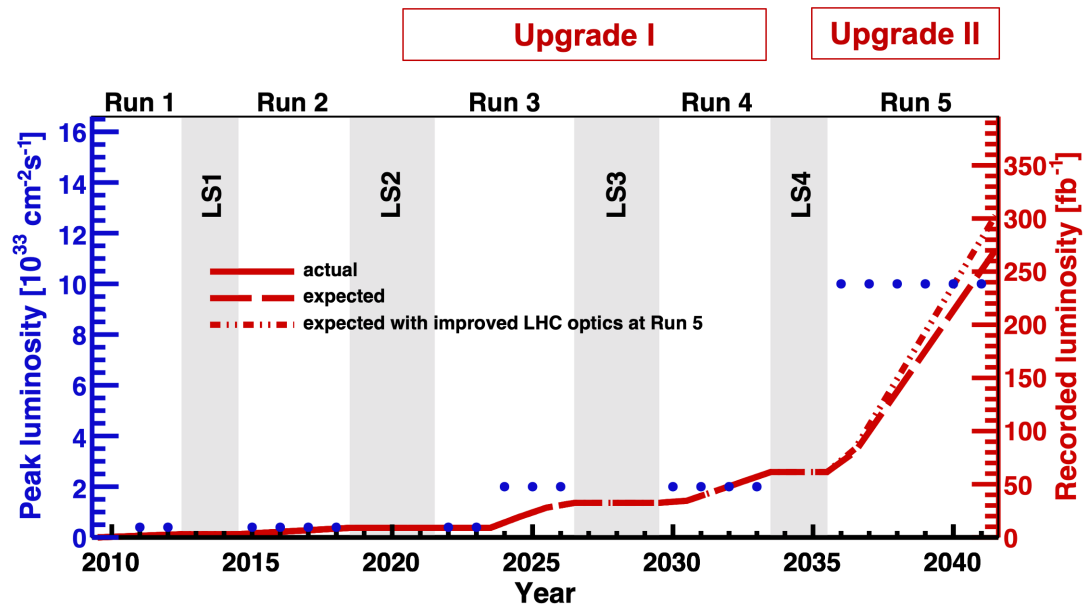

Dedicated gas target (SMOG)

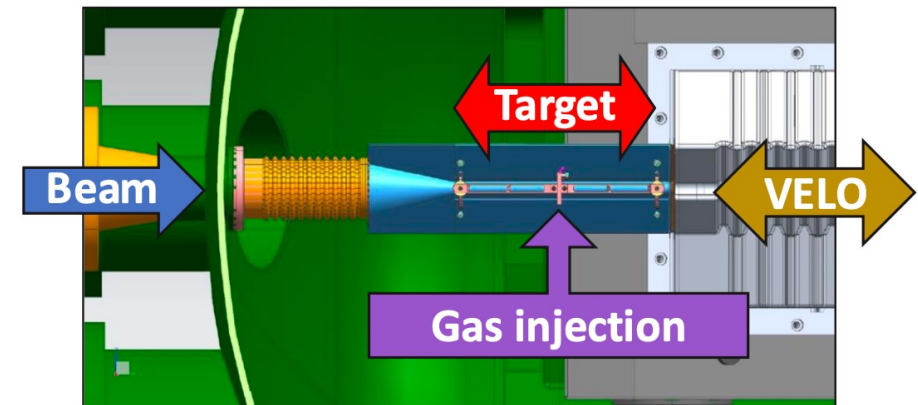

Backup slides

Heavy quarkonia production

- Factorization methods

$$\sigma(ij \rightarrow H + X) \leftarrow \sum_n \underbrace{\sigma(ij \rightarrow Q\bar{Q}[n]X)}_{\text{Perturbative}} \underbrace{\langle Q\bar{Q}[n] \rightarrow H \rangle}_{\text{Non-perturbative}} \quad n: \text{spin, parity, color indices}$$

- **Color singlet mechanism (CSM):** $Q\bar{Q}[n]$ color singlet state, coincides with final state quarkonium J^{PC} quantum number
- **Non-relativistic QCD approach (NRQCD):** Both color singlet and octet, all viable J^{PC} states allowed with varying probabilities (long distance matrix elements, **LDME**)
 - ❑ LDME non perturbative, **universal**, obtained from data
 - ❑ Leading LDMEs for J/ψ production: ${}^3S_1^{[1]}$, ${}^3S_1^{[8]}$, ${}^1S_0^{[8]}$, ${}^3P_J^{[8]}$
- **Color evaporation model:** fixed rate for all $Q\bar{Q}$ pairs with $m_{Q\bar{Q}} < 2m_{H_Q}$
 - ❑ Improved version: $m_{H_{QQ}} < m_{Q\bar{Q}} < 2m_{H_Q}$

Enhancement of double parton scattering

Single-parton scattering (SPS)

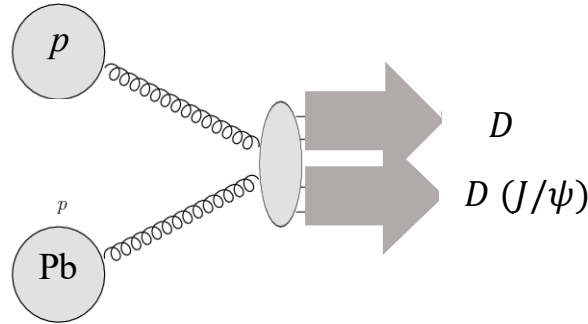

Double-parton scattering (DPS)

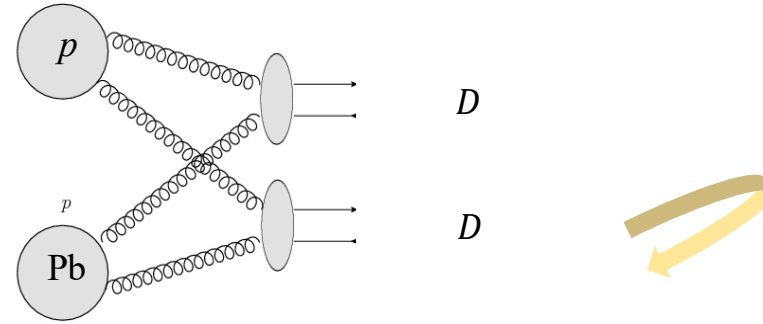

- If two collisions uncorrelated: DPS cross-section $\sigma^{HQ_1HQ_2} = \kappa \frac{\sigma^{HQ_1} \sigma^{HQ_2}}{\sigma_{\text{eff}}}$
 σ_{eff} : related to geometry, final state independent, universal
- DPS production enhanced in heavy ion collisions, compared to AB scaling

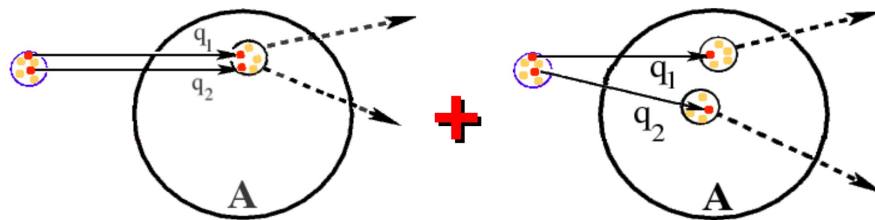

$$\sigma_{(pA)}^{\text{DPS}} = \sigma_{(pA)}^{\text{DPS},1} + \sigma_{(pA)}^{\text{DPS},2}$$

PRL 118 (2017) 122001

Enhancement factor is about three in pPb collisions

Λ_c^+ polarization

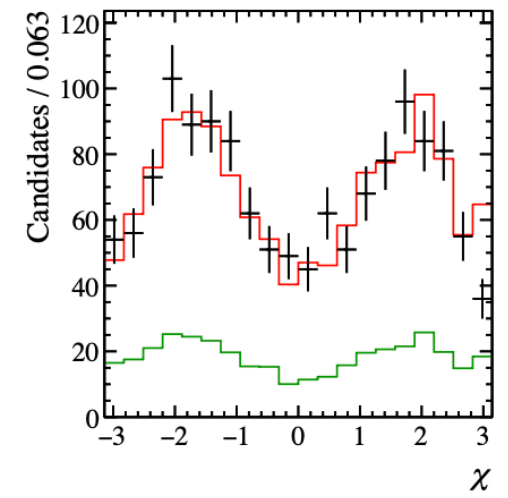
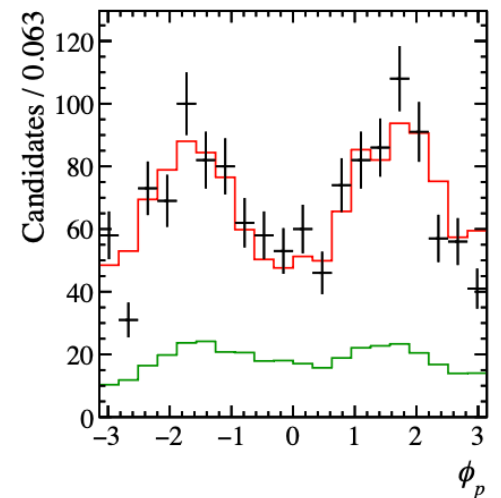
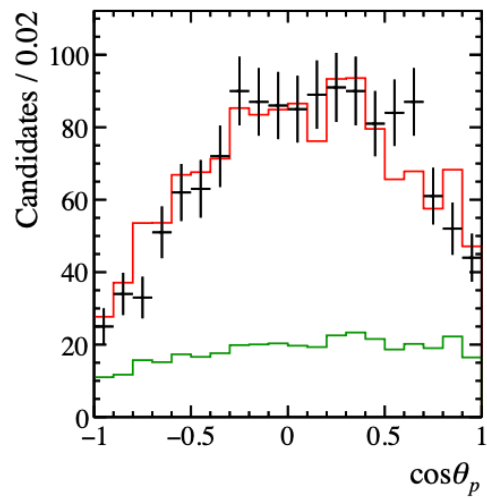
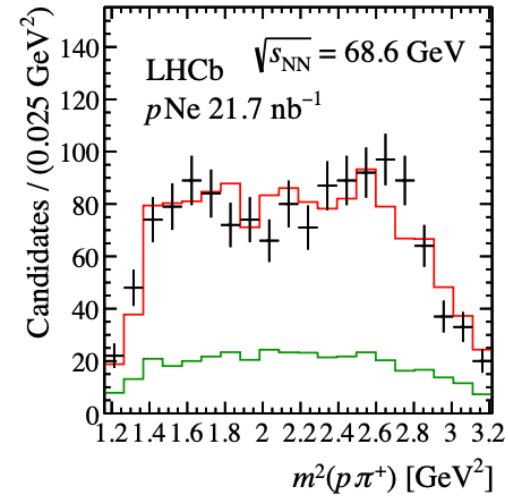
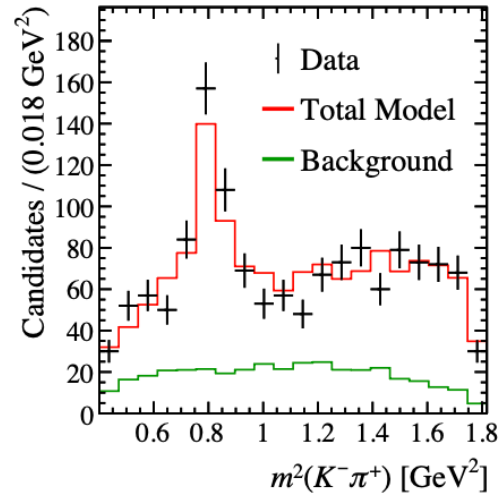
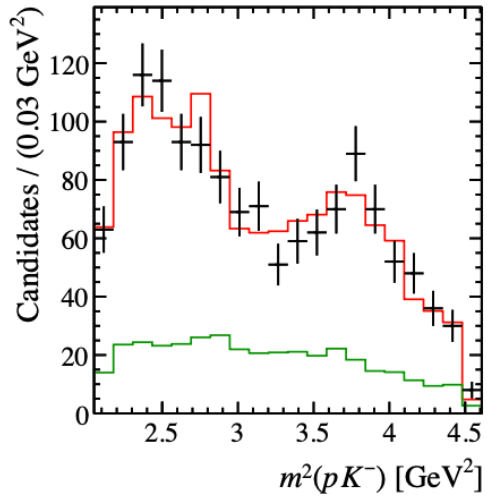

SMOG setup

LHCb as fixed gas target experiment

A gas storage cell can boost the gas density by up to two orders of magnitude for the same flow as with SMOG

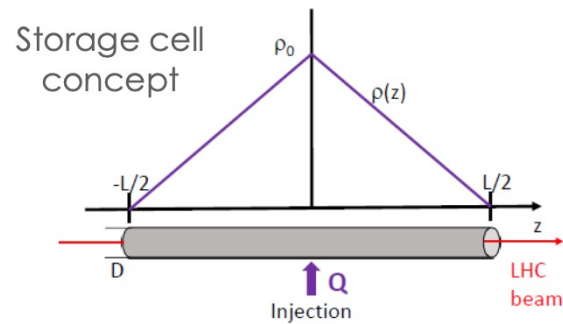

Open-ended tube

SMOG2

PR ACCELERATORS AND BEAMS 27, 111001 (2024)

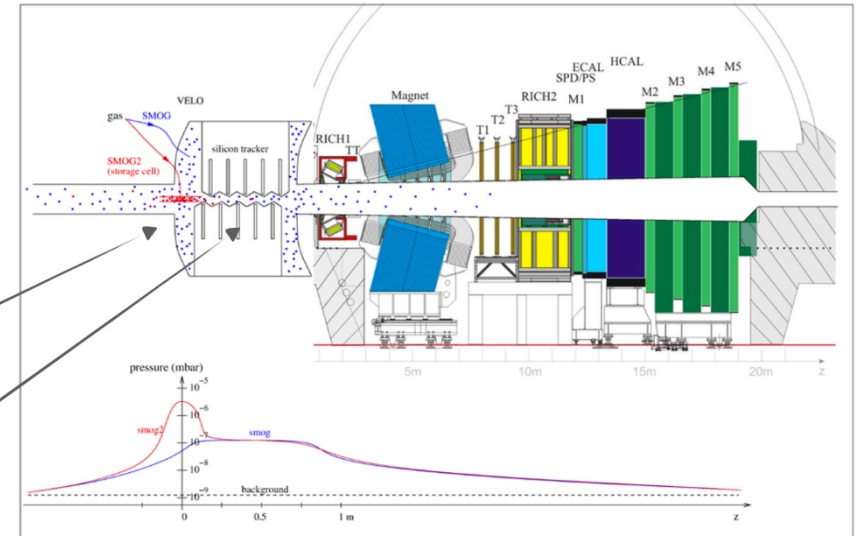
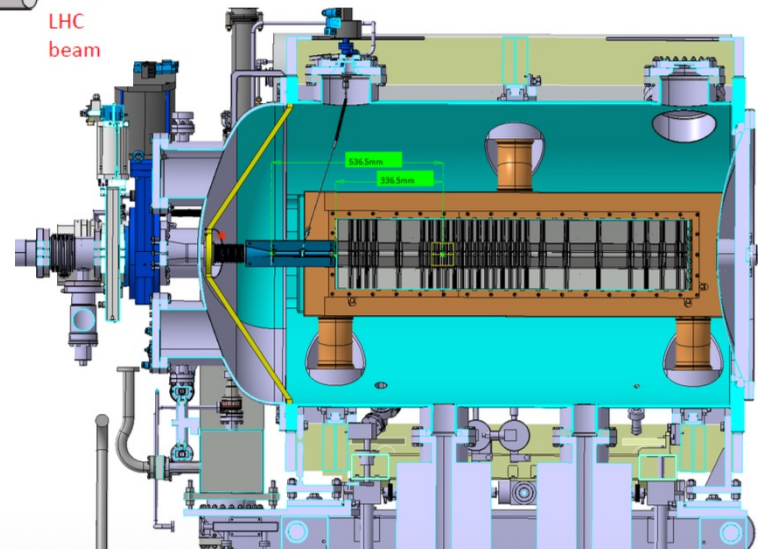

The $PV_{p\text{-gas}}$ and $PV_{\text{beam-beam}}$ are well separated, no need for dedicated runs

Zoom into the VELO region

Neon nucleus structure from collision

- Charged particle flow in heavy ion collisions allows to probe nucleus structure
- Distinct v_2 flow fixed-target PbNe and PbAr collisions
 - Agree with predictions using hydrodynamics and nucleus shape
 - Support the bowling-pin shape of the ^{20}Ne ground-state

