

# Dijet production in intermediate $x$ at EIC

Zhang Yuan-Yuan (SWJTU)

Collaborator : Yu Fu(Duke), Xin-Nian Wang(CCNU)

第一届中国电子离子对撞机相关物理年会

中国青岛 2026-04-21





# CONTENTS

**Background: Building the bridge between large/small  
X**

**Photon-Gluon Fusion using Generalized High-Twist  
approach**

**Summary and Outlook**



# Different processes dominates at large/small $x$

QCD Compton(QCDC) - large  $x$

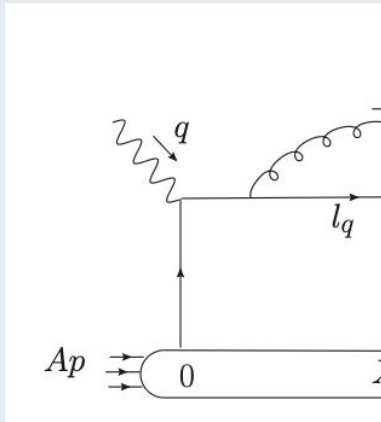

Photon-Gluon Fusion(PGF) - small  $x$

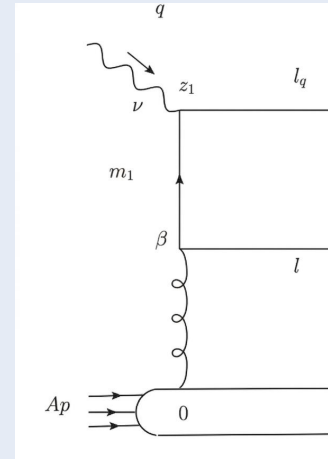

# Different processes dominates at large/small $x$

QCD Compton(QCDC) - large  $x$

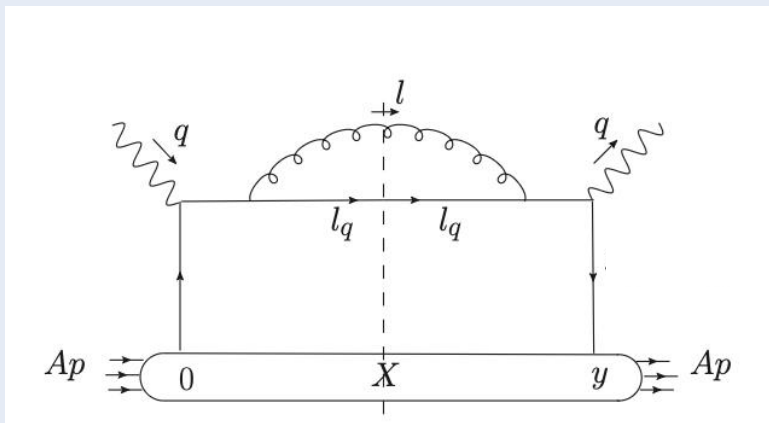

Photon-Gluon Fusion(PGF) - small  $x$

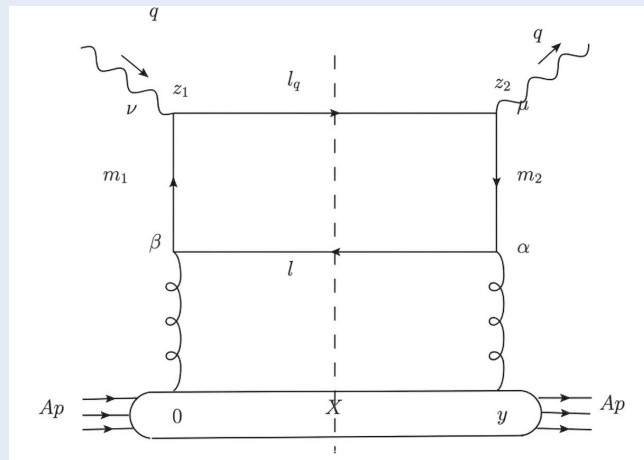

building the bridge

# LPM effect at large $x$

medium-induced radiation

medium gluon kick the radiated gluon

→ influence gluon formation time  $\tau_f$

LPM factor:  $1 - \cos \frac{y^-}{\tau_f}$

in QGP : jet energy loss

{ LBT model

in cold nuclei : dijet rapidity gap/ $rA$  distribution

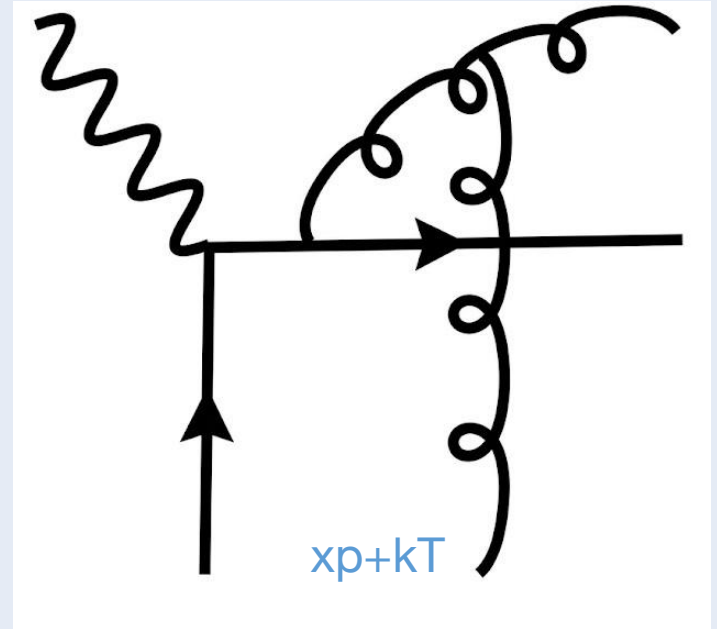



# Efforts from two direction

small-x  $\rightarrow$  large-x

- Sub-eikonal (finite width nucleus)

restore the longitudinal phase factor  $e^{ixpy^-}$

S Mukherjee *et al.* arXiv:2602.15137

P Agostini, T Altinoluk, N Armesto, JHEP 07 (2024) 137

large-x  $\rightarrow$  small-x

- CGC add longitudinal phase, expand in  $A^+$ , match High-Twist Result (pA)

Y Fu, Z-B Kang, X-N Wang, H-X Xing

Phys.Rev.Lett. 135 (2025) 3, 032301

# Photon-Gluon Fusion using Generalized High-Twist Approach

1. Calculate  $\sigma_{\gamma^*g} = \frac{e^2}{2s} (-g^{\mu\nu}) W^{\mu\nu}$

2. Check Leading Twist result, agree with textbook/other paper results

F Dominguez, C Marquet , B-W Xiao, F Yuan  
Phys.Rev.D 83 (2011) 105005

Z-B Kang, E Wang , X-N Wang, H-X Xing Phys.Rev.D  
94 (2016) 11, 114024

# Photon-Gluon Fusion Leading Twist Diagrams

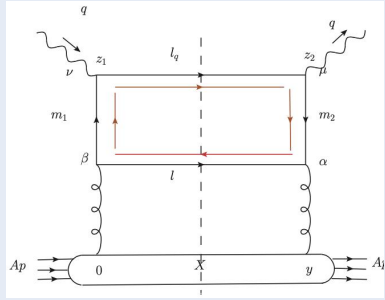

LT-1

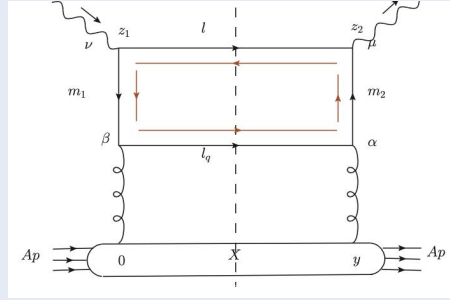

LT-2

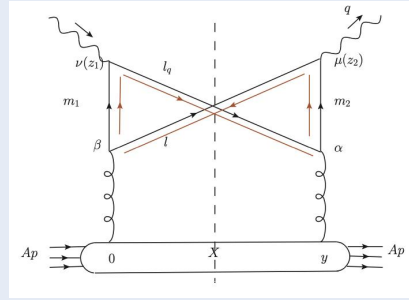

LT-3

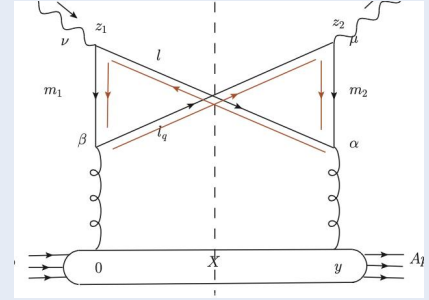

LT-4

# Photon-Gluon Fusion Twist-4 -Diagrams

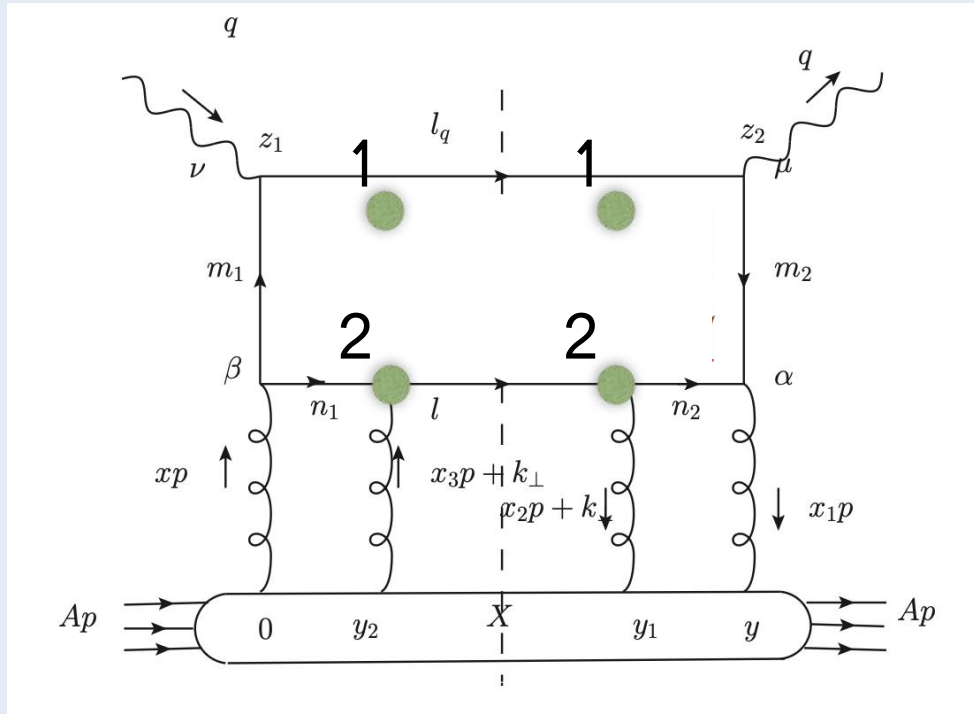

C22 diagram

# Photon-Gluon Fusion Twist-4 -Diagrams

left-cut ,central cut, right cut

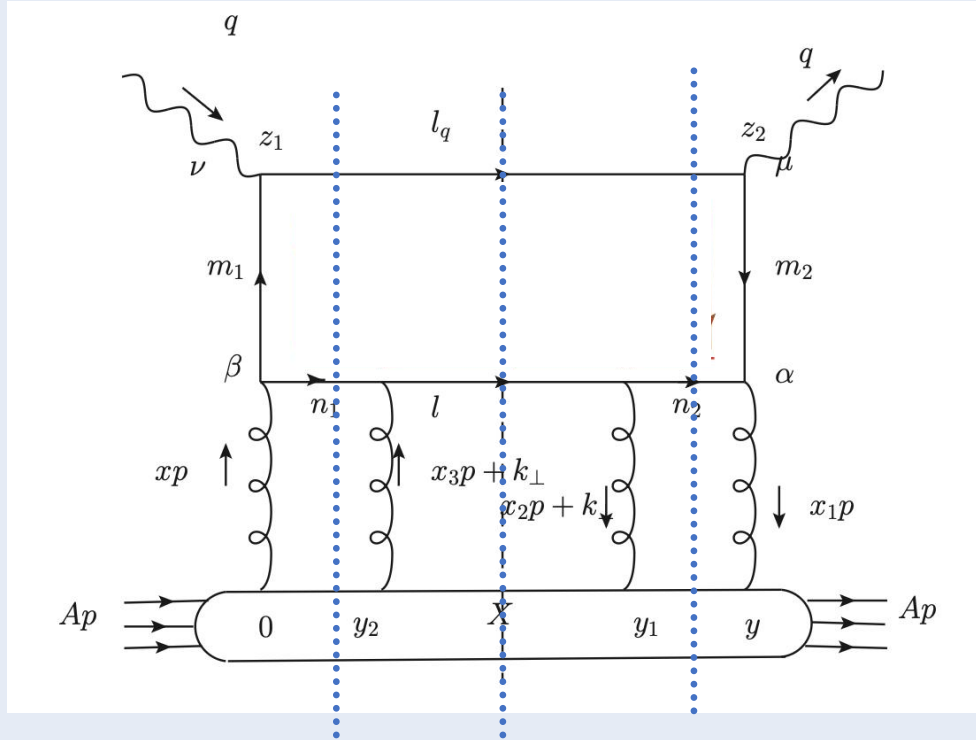

# Photon-Gluon Fusion Twist-4 -Results

$$\frac{d\sigma_{\Sigma}}{dy_1 dy_2 d^2l_{1\perp} d^2l_{2\perp}} \propto \rho(y_0) x_0 f_g(x_0) \rho(y_1) \frac{\Phi(x_1, k_{\perp})}{k_{\perp}^2} \{C_{11} + 3C_{22} + 3C_{12} + R_{21}$$

$$- 3C_{12} \times [1 - \cos(\frac{x_D p^+ y_1^-}{1-z})] - R_{21} \times [1 - \cos(\frac{x_C p^+ y_1^-}{1-z})]\}$$

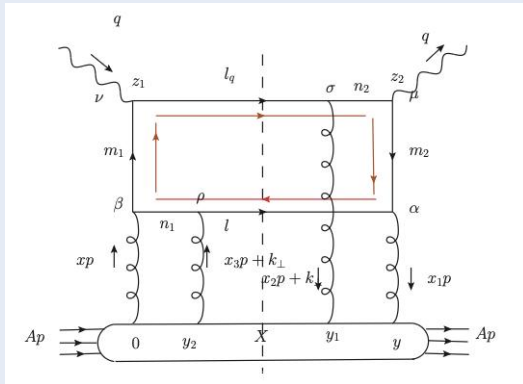

C21 diagram

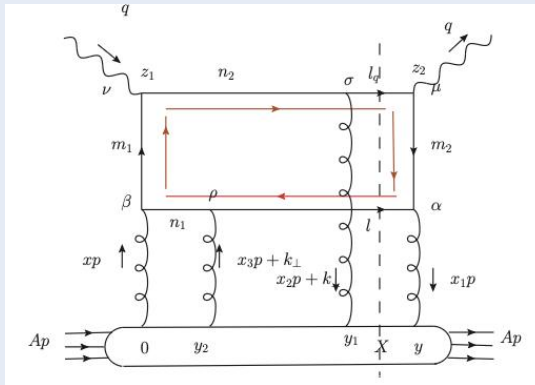

R21 diagram

... total 48 diagrams

## Photon-Gluon Fusion Twist-4 -Results

$$\frac{d\sigma_{\Sigma}}{dy_1 dy_2 d^2l_{1\perp} d^2l_{2\perp}} \propto \rho(y_0) f(x_0) \rho(y_1) \frac{\Phi(x_1, k_{\perp})}{k_{\perp}^2} \{C_{11} + 3C_{22} + 3C_{12} + R_{21}$$

$$- 3C_{12} \times [1 - \cos(\frac{x_D p^+ y_1^-}{1-z})] - R_{21} \times [1 - \cos(\frac{x_C p^+ y_1^-}{1-z})]\}$$

$$C_{11} = \frac{T_R^2}{N_c} F(\vec{l}_{1\perp} - \vec{k}_{\perp})$$

$$C_{22} = \frac{T_R^2}{N_c} F(\vec{l}_{1\perp})$$

$$C_{12} = -\frac{T_R^2}{N_c(N_c^2 - 1)} H(\vec{l}_{1\perp} - \vec{k}_{\perp})$$

$$R_{12} = -\frac{T_R^2}{N_c(N_c^2 - 1)} H(\vec{l}_{1\perp} + \vec{k}_{\perp})$$

cross term suppressed by  $\frac{1}{N_c^2-1}$

# Photon-Gluon Fusion Twist-4

## - reproduce CGC at back-to-back limit

Under  $k_{\perp} \ll l_{\perp}$  approx, dipole size ( $r_{\perp} \sim \frac{1}{[l_{\perp} - (1-z)k_{\perp}]}$ ) very small, medium can not resolve  $q$  and  $qbar$ , different gluon attachment are the same

$$C'_{11} = C'_{22} = C'_{12} = R'_{12} = T_R F(\vec{l}_{1\perp}) t^a t^a$$

$$\frac{d\sigma_{\Sigma}}{dy_1 dy_2 d^2l_{1\perp} d^2l_{2\perp}} \propto x G(x, k_{\perp}) F(\vec{l}_{1\perp})$$

$t^a$  in gauge-link  $-igt^a \int d\zeta^- A^+(\zeta^-)$

# Numerical Results-ygap distribution

ygap: rapidity gap between two jet  $|y_1 - y_2|$

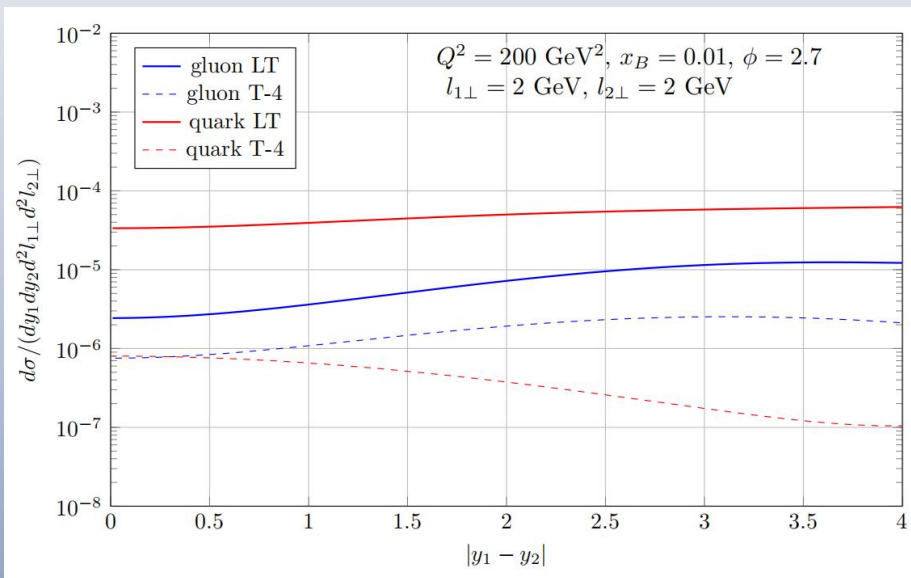

$$\frac{d\sigma_{\Sigma}}{dy_1 dy_2 d^2l_{1\perp} d^2l_{2\perp}}$$

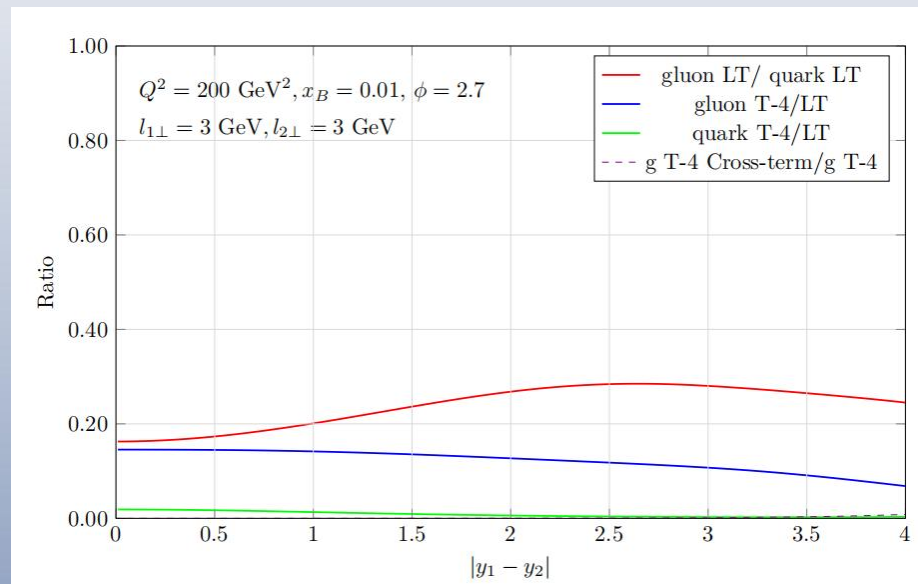

Ratio

# Numerical Results- $\phi$ distribution

$\phi$ : angle between  $l_{1\perp}$  and  $l_{2\perp}$

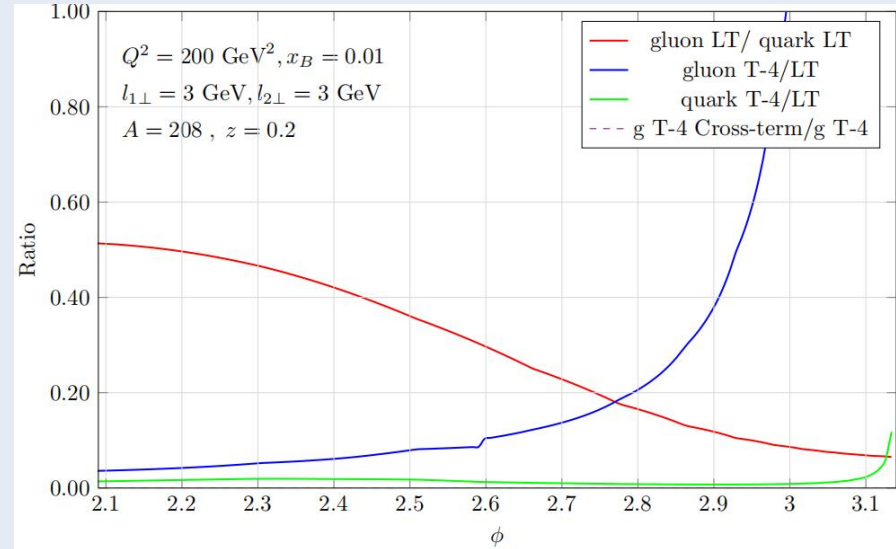
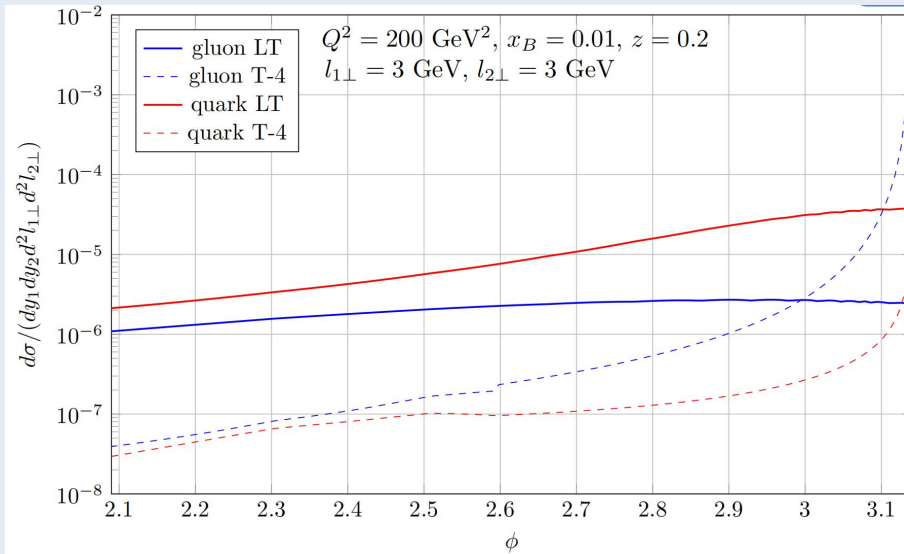

cross-term is 0.1% of total gluon Twist-4

# Summary and Outlook

Get photon-gluon fusion Twist-4 result, find cross term suppressed by  $\frac{1}{N_c^2-1}$

Calculate quark LT& T4, gluon LT &T4 result, cross term contribute 0.1%

Implement to ehijing, large-x and intermediate-x using same method

Compare with small-x CGC sub-eikonal results

THE END

THANKS

