

Recent Progress of Studying Nucleon Structure at Jefferson Lab

Selected Highlights in 2025-2026

Zhihong Ye

Department of Physics, Tsinghua University

2026-04-19



Jefferson Lab Overview

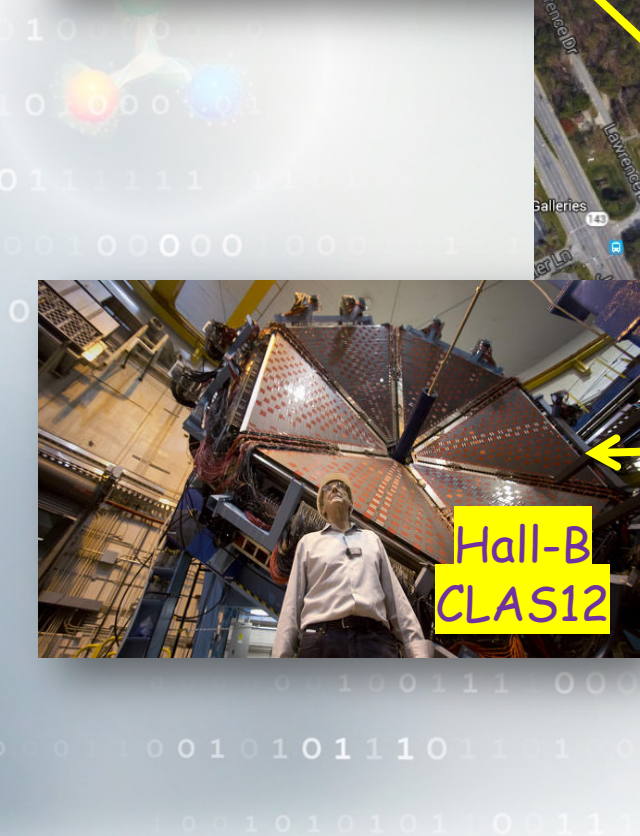
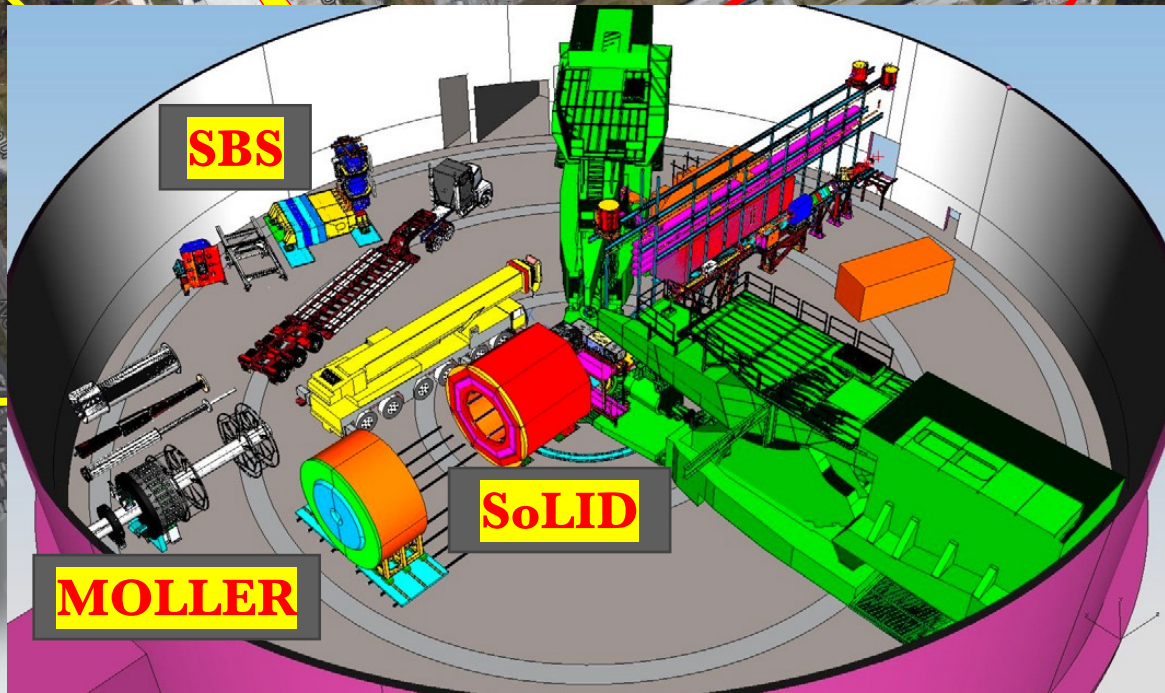
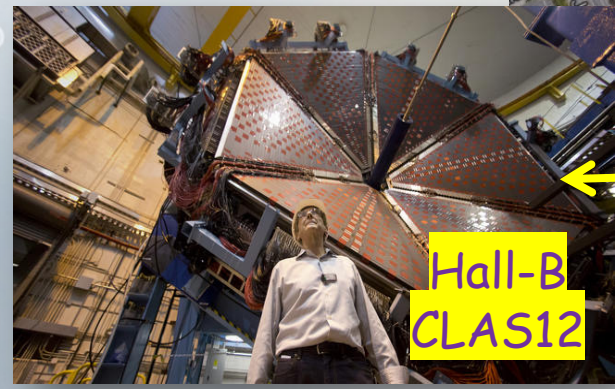
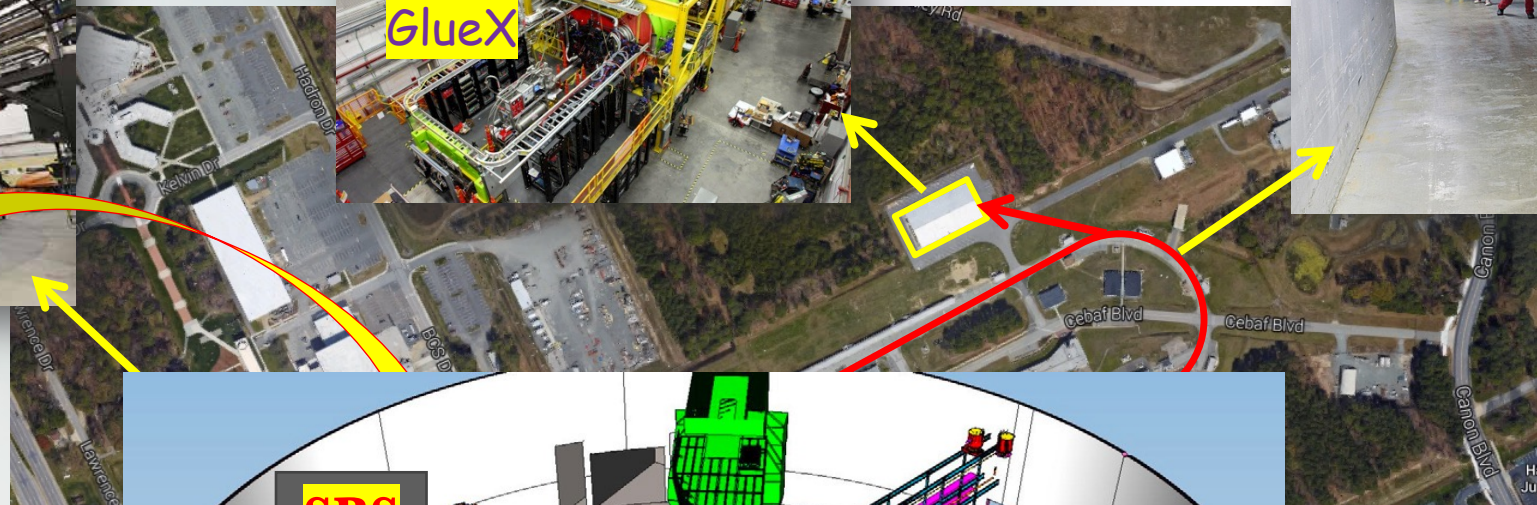
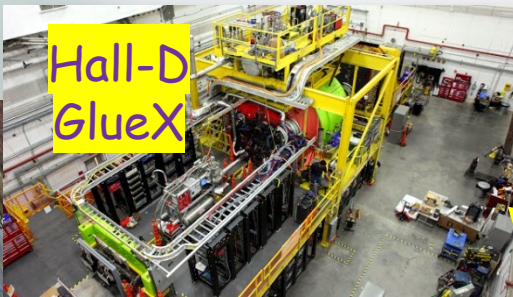

Jefferson Lab Overview

☐ **Features:** High **luminosity** ($10^{39} \text{ cm}^{-2}\text{s}^{-1}$); **polarized** beam & targets; high-**precision** detectors; four halls operation simultaneously; 10.6GeV/c for Hall A&B&C, 12GeV/c (to $\sim 8\text{GeV}$ photons) for Hall-D

☐ **Top Missions:**

- ✓ Explore hadronic structure and interactions in nuclei (EMC, SRC, Hypernuclei, etc.)
- ✓ Discover evidence for physics BSM (PVDIS, beam-dump experiments)
- ✓ Explore the fundamental nature of confined states quarks and gluons (**from 1D to 3D, Exotic Hadrons**)

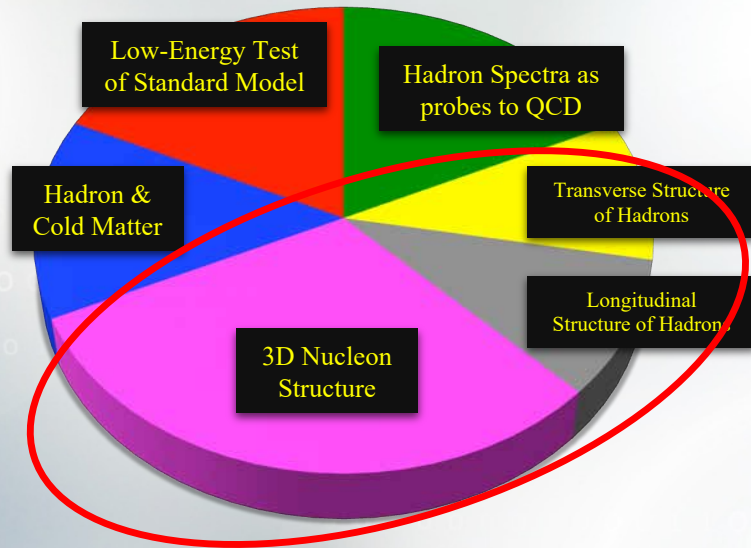

☐ JLab kinematic probe partonic structure in **valance quark** region (non-pQCD)

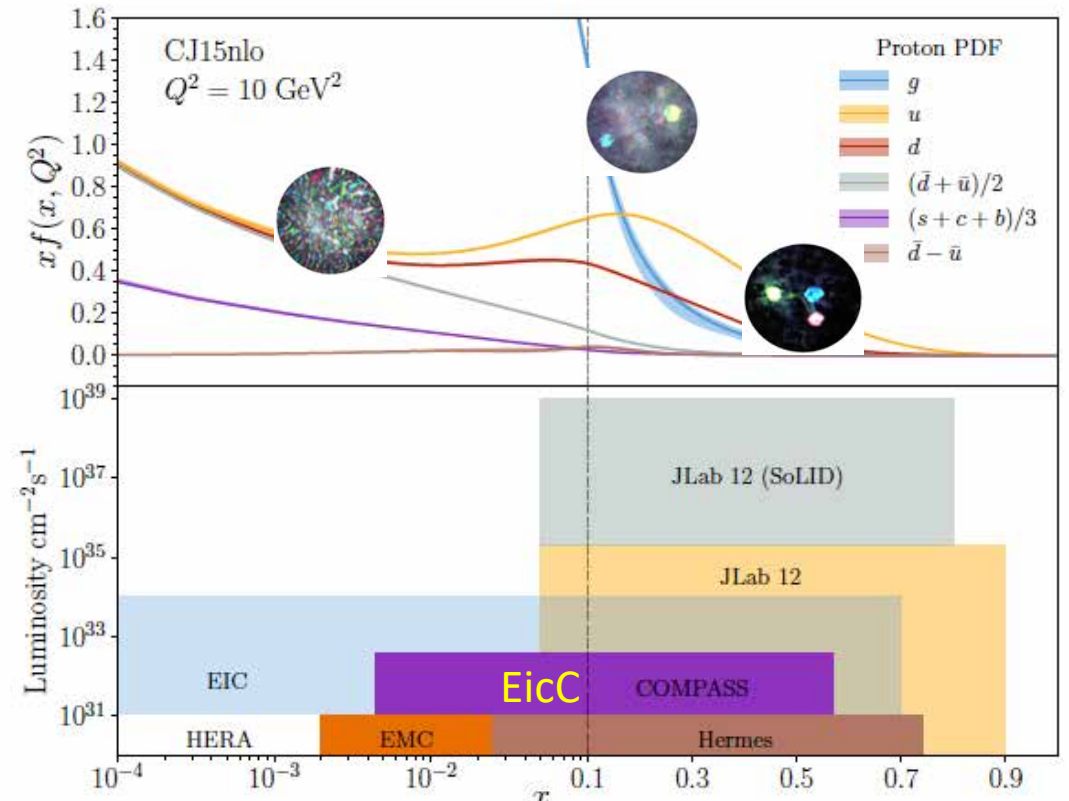

Overview of Nucleon Structure Study

		Quark Polarization		
		Unpolarized (U)	Longitudinally Polarized (L)	Transversely Polarized (T)
Nucleon Polarization	U	H		$2\tilde{H}_T + E_T$
	L		\tilde{H}	\tilde{E}_T
	T	E	\tilde{E}	H_T, \tilde{H}_T

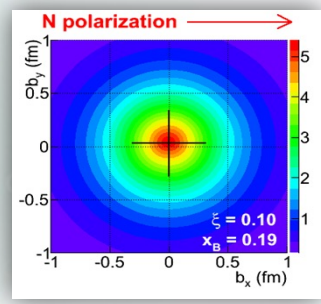

See X.D. Ji's talk on Wednesday

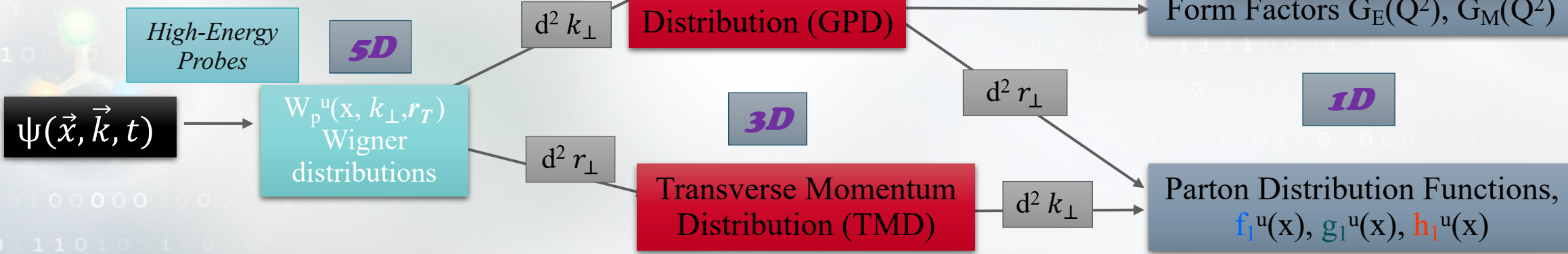
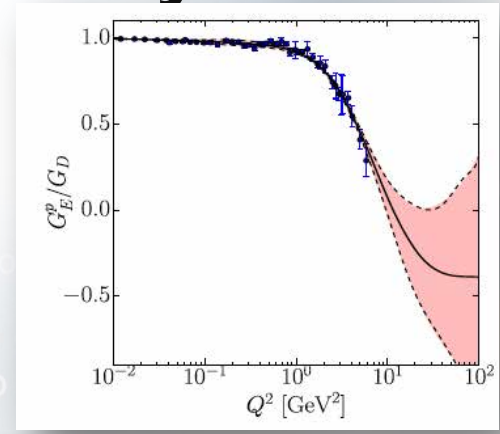

Leading Twist TMDs		Quark Polarization		
		Unpolarized (U)	Longitudinally Polarized (L)	Transversely Polarized (T)
Nucleon Polarization	U	$f_1(x, k_T^2)$ Unpolarized		$h_1^+(x, k_T^2)$ Boer-Mulders
	L		$g_1(x, k_T^2)$ Helicity	$h_{1L}^+(x, k_T^2)$ Long-Transversity
	T	$f_{1T}^+(x, k_T^2)$ Sivers	$g_{1T}(x, k_T^2)$ Trans-Helicity	$h_1(x, k_T^2)$ Transversity $h_{1T}^+(x, k_T^2)$ Pretzelosity

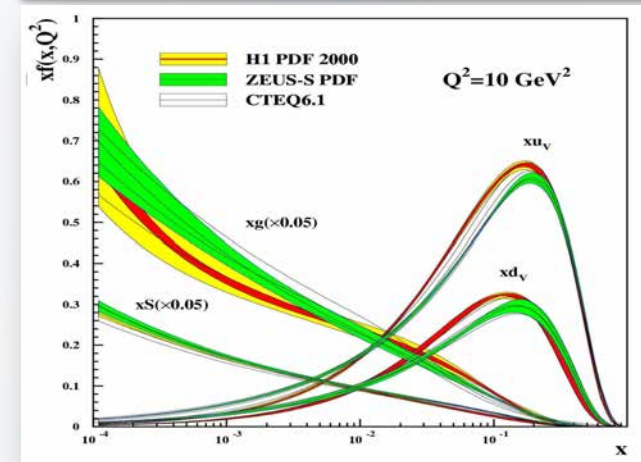
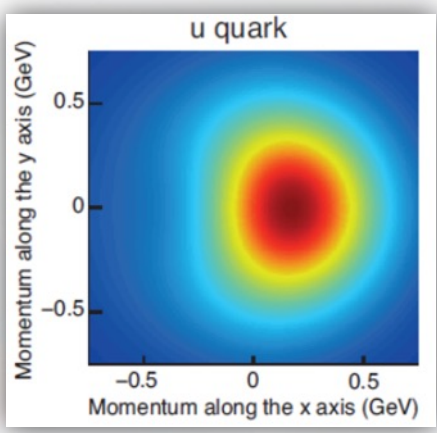

Form-Factors

- e/p & e/n elastic scattering cross-sections:
$$\frac{d\sigma}{d\Omega} = \left(\frac{d\sigma}{d\Omega}\right)_{\text{Mott}} \frac{1}{1+\tau} \left[(G_E^p(Q^2))^2 + \frac{\tau}{\epsilon} (G_M^p(Q^2))^2 \right]$$
- Form-factors link to charged distributions:
$$G_{E,M}^p(Q^2) = \int \left(1 + i\vec{q} \cdot \vec{x} - \frac{(\vec{q} \cdot \vec{x})^2}{2} + \dots \right) \rho_{E,M}^p(\vec{x}) d^3x$$
- Precisely measured since 1950s

Most recent global analysis: Z. Ye, J. Arrington, R. Hill, G. Lee, Phys. Lett. B777, 8-15 (2018)

- **Focus now**: protons FFs at very high- Q^2 & low- Q^2 (radii), neutron-FFs

- Newly extracted proton FFs up to 4.1 GeV^2 from old Hall-C data

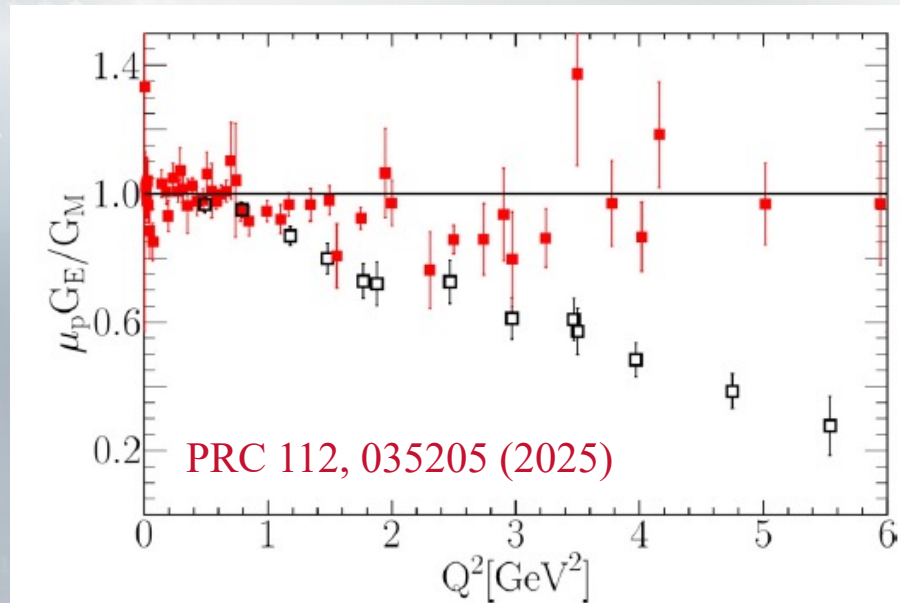

- Updated global fits underway based on **newest neutron FF** results from Tritium@Hall-A

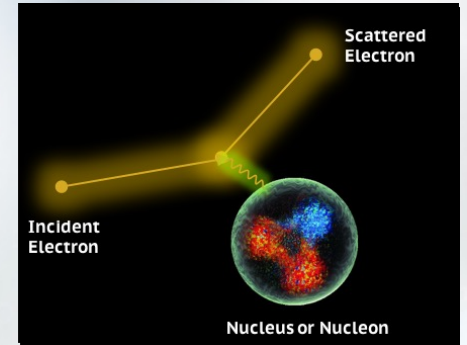
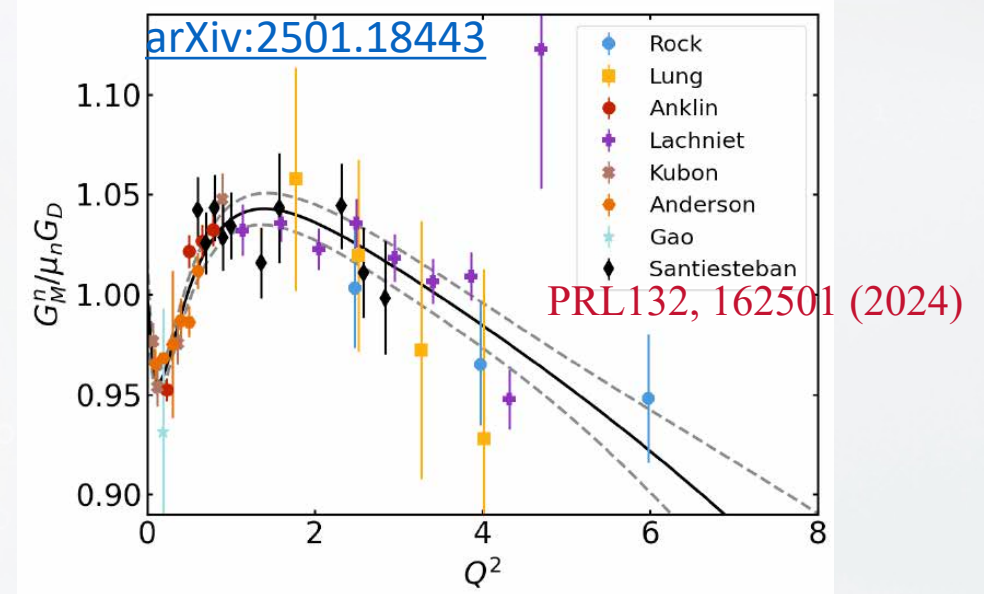

Form-Factors

- ❑ Hall-A SBS aim to measure FF at high- Q^2

The Super Bigbite Spectrometer for GEp



The Super Bigbite Spectrometer

- Large dipole magnet
- Polarimeter
 - GEM tracking layers
 - CH₂ analyzer
 - GEM tracking layers
- Hadron Calorimeter

The Electron Arm

- Poly shield for neutron absorption
- Scintillator based Coordinate Detector
- Electron Calorimeter

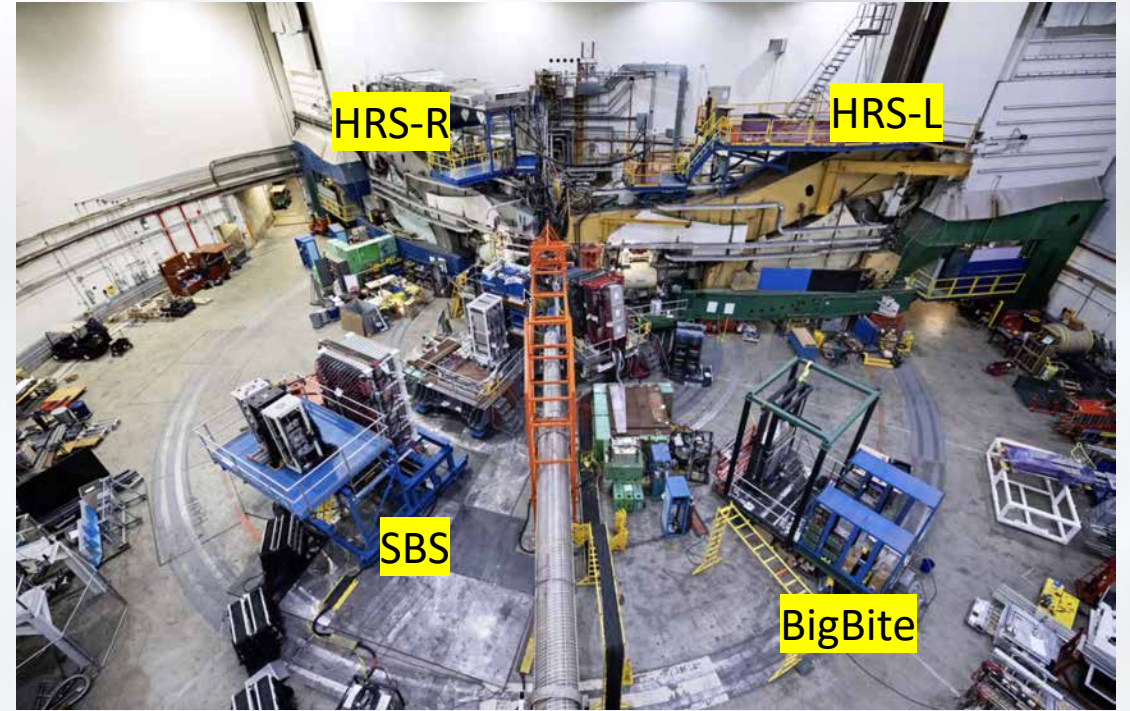
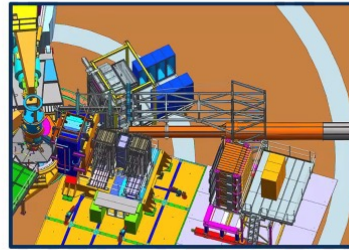
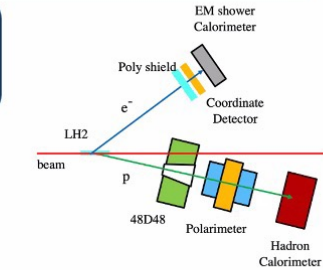
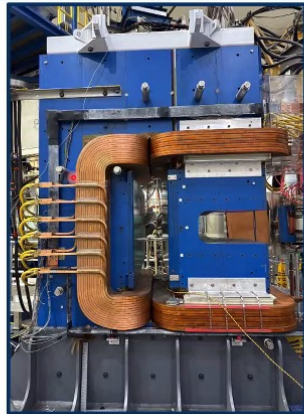

October 19, 2025

Jacob McMurtry, University of Virginia - Chicago, IL

8

- ❑ Data partially taken (Aug 2025);
- ❑ New FF data to be taken in 2028

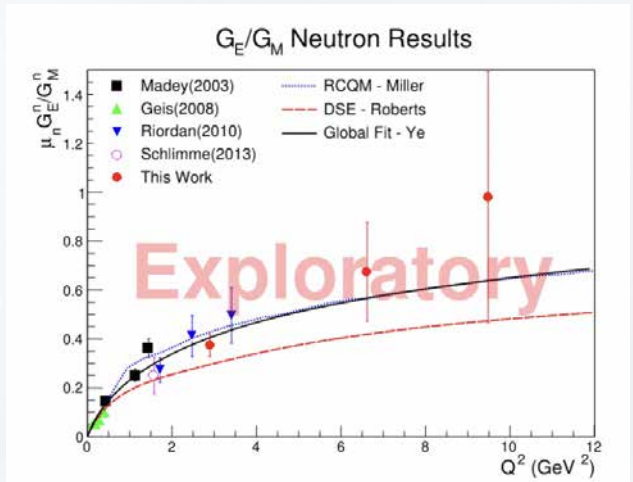
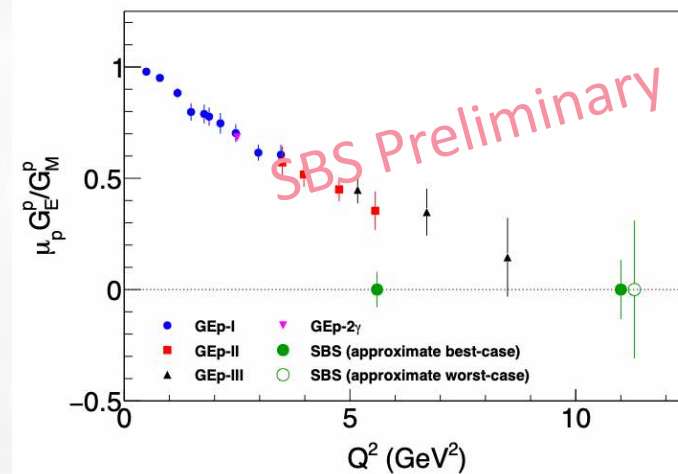

Proton Charged Radius

❑ Proton charged radius can be extrapolated via low-Q² FF data

$$r_p \equiv \left(-6 \frac{dG_E(Q^2)}{dQ^2} \Big|_{Q^2=0} \right)^{1/2}$$

❑ PRAD-I result conformed a smaller radius

❑ PRAD-II aims for completely resolving proton radius puzzle (**running now!**)

Xiong, et. al. *Nature* 575, 47–150 (2019) [JLab]

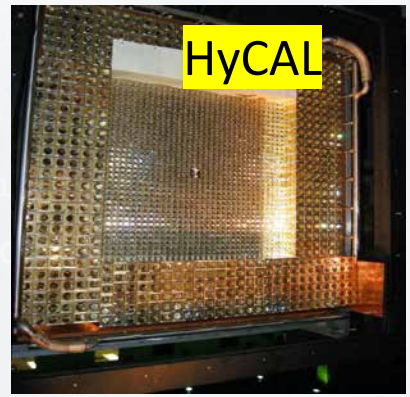
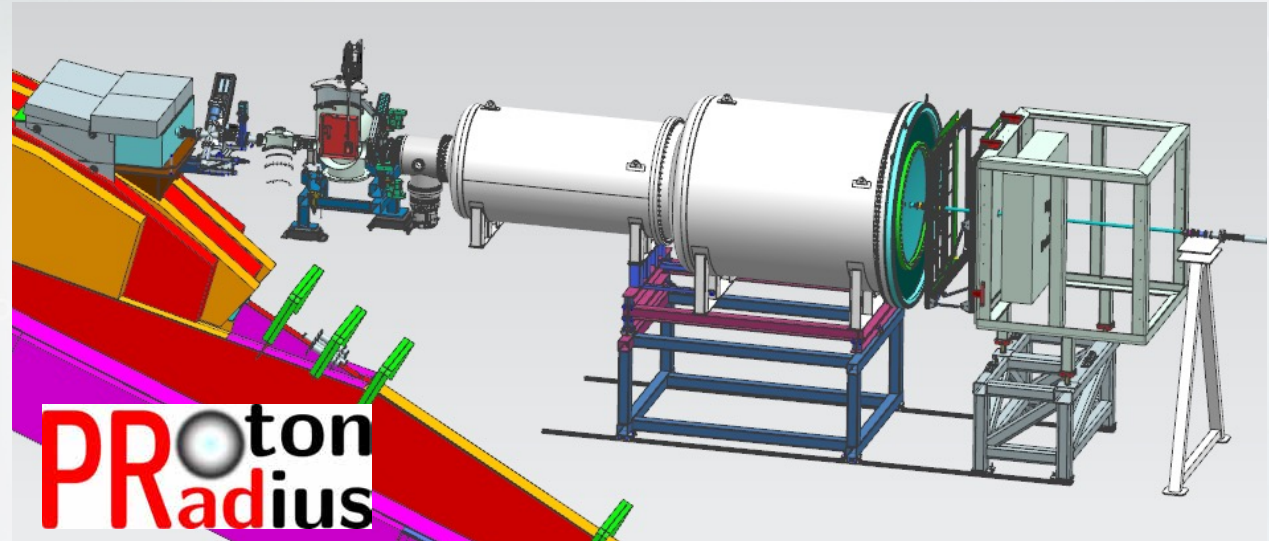
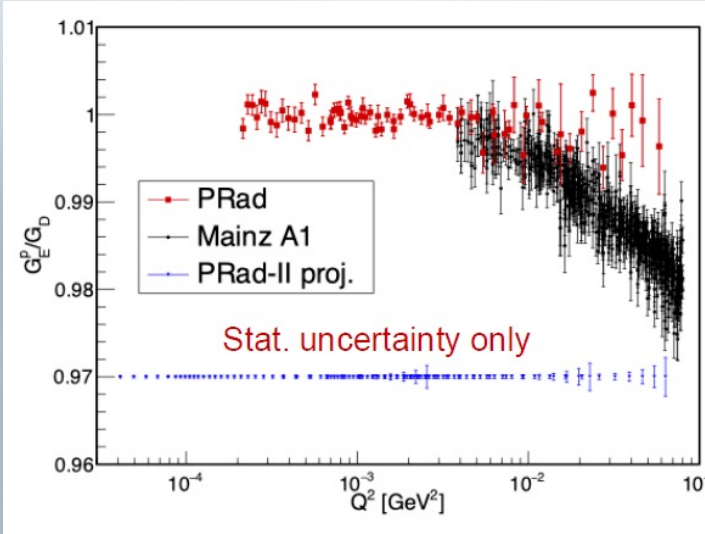
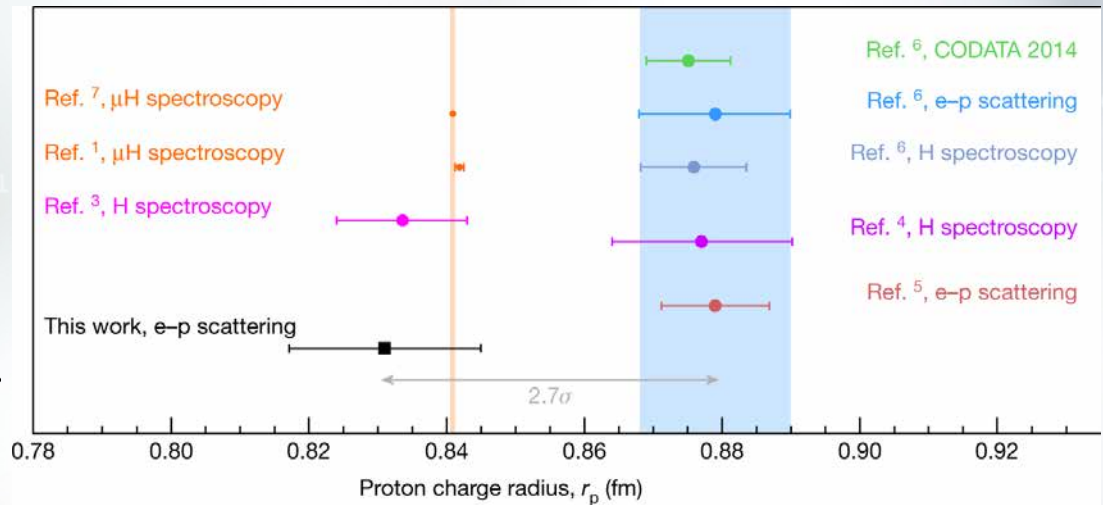

Parton Distribution Function (PDFs)

- DIS cross-section to F_2 , hence to PDF sum:

$$\frac{d^2\sigma}{d\Omega dE'} = \sigma_{\text{Mott}} \frac{2MxF_2}{Q^2\varepsilon} \left(\frac{1+\varepsilon R}{1+R} \right) \quad F_2(x) = x \sum_i e_i^2 f_i(x)$$

- $R = \sigma_L/\sigma_T$, link to mass/high-twist/ P_T -motion, Rosenbluth separation needed; Small at $Q^2 > 10 \text{ GeV}^2$ or $x > 0.5$
- 2D (effective “n”) need high-precision for nuclear-correction (incl. R)
- Hall-C E12-10-002 experiment recently extract σ_D/σ_H at large x
- Measure R in SIDIS π cross-section (E12-06-104/E12-24-001):

$$d\sigma_{\text{SIDIS}} \propto F_{UU,T}(x, Q^2, z, P_{hT}) + \epsilon F_{UU,L}(x, Q^2, z, P_{hT})$$

$$R_{\text{SIDIS}} = \frac{F_{UU,L}}{F_{UU,T}}$$

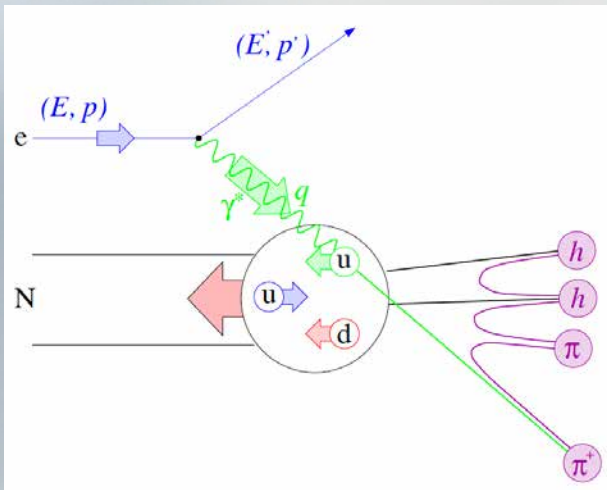

- ✓ Could be big and flavor-dep.
- ✓ Diff. from DIS
- ✓ Difficult in Rosenbluth separation
- ✓ completed run in 2025-2026@ Hall-C
- ✓ More R measurements in 2026/2027

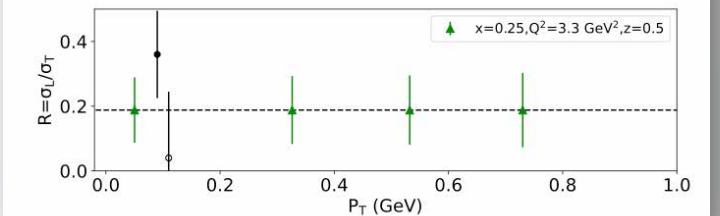
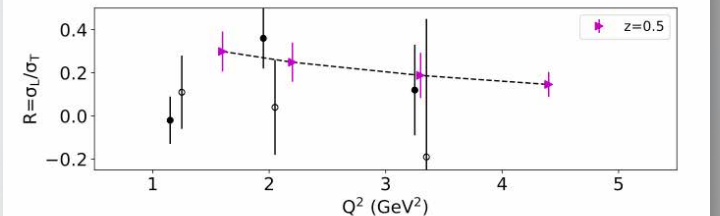
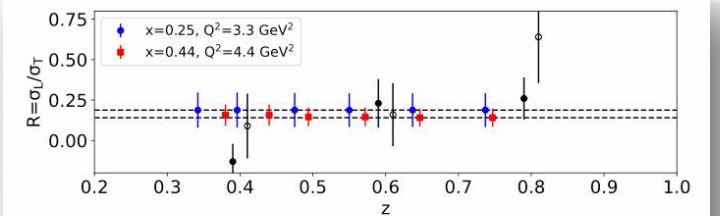
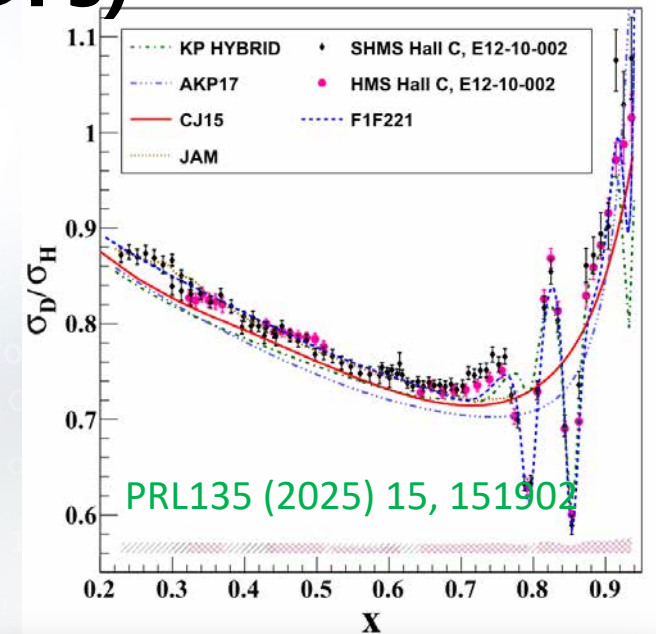

PDFs in Nuclei

- ❑ 1D Partonic Structure in heavy nuclei shows EMC effect
 - 40 years of puzzle waiting to be answer
- ❑ Quark PDFs in light nuclei ($A=3$) is also likely to be modified

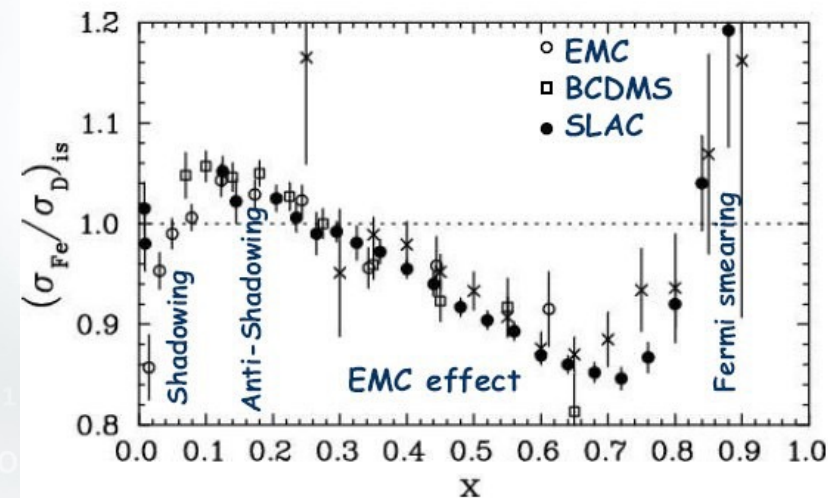
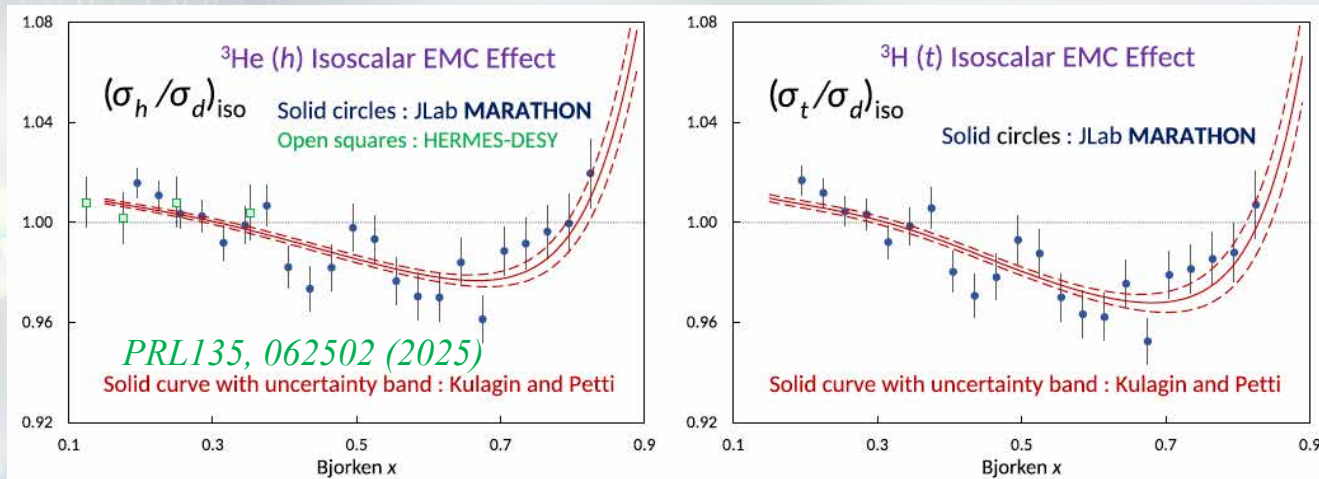

- ❑ Flavor-dependent EMC effect: which quark is modified more?
 - ✓ Second generation Tritium experiment: SIDIS w/ CLAS12
 - ✓ Beam-Time request submitted in 2026 PAC

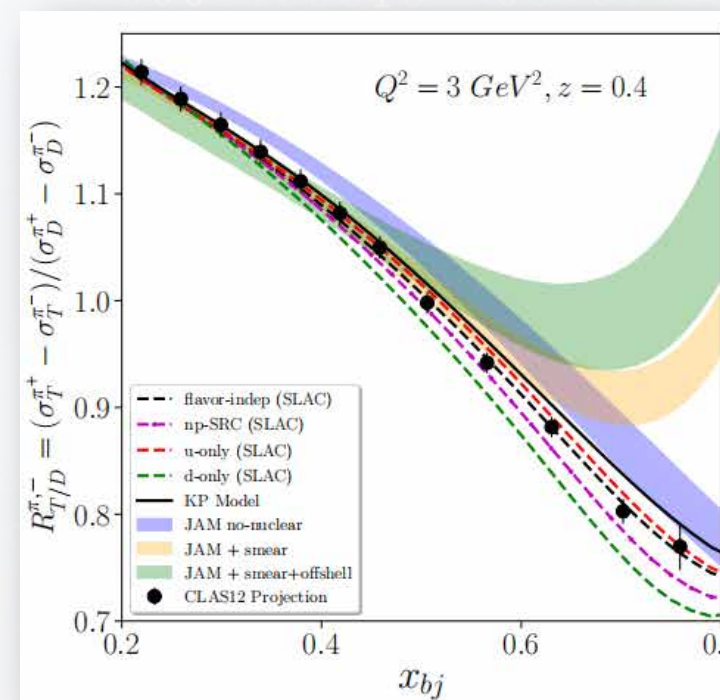
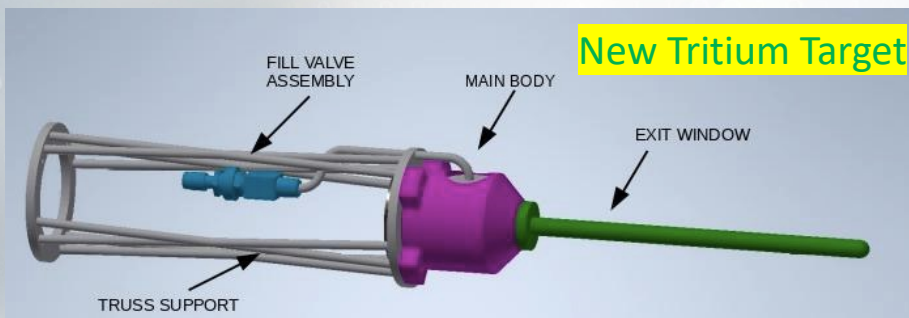

PDFs in Nuclei

❑ EMC link to the SRC?

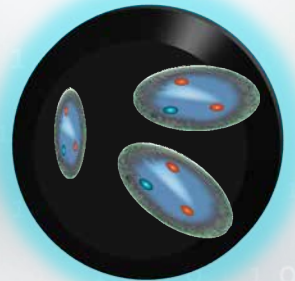

Modified in Medium

or

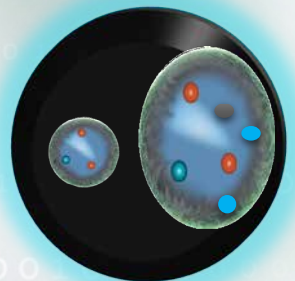

Modified in SRC

❑ Tagged DIS w/ He4 using ALERT@CLAS12, Hall-B

- ✓ ALERT to detect low-P spectator proton
- ✓ Measure EMC@10.6GeV & SRC@6.6GeV
- ✓ Completed in late 2025; Analyzing data now

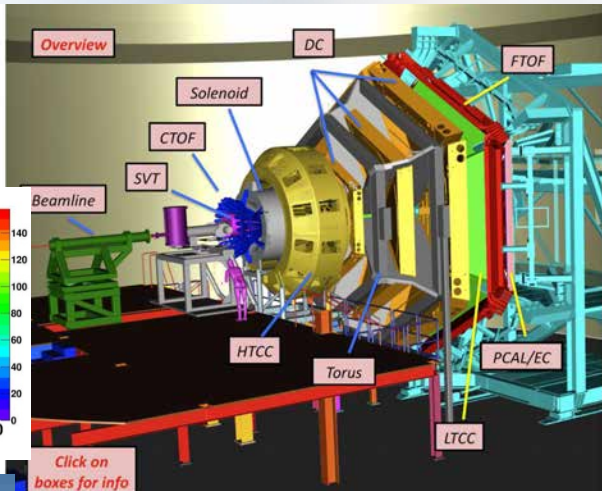
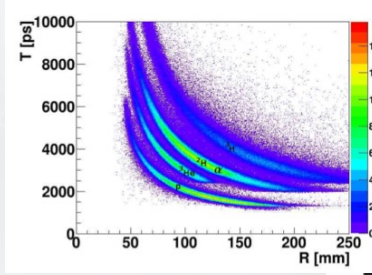
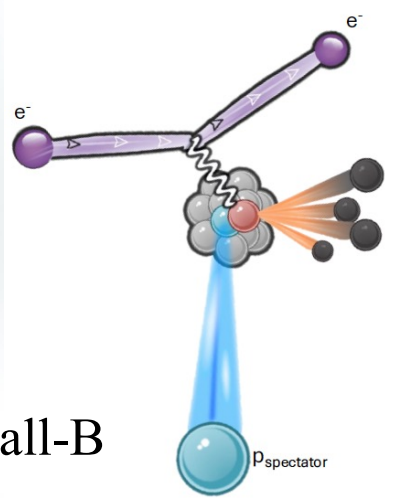

Click on boxes for info

ALERT Recoil Detector

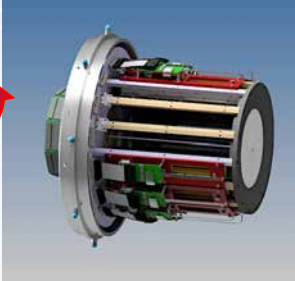

❑ Tagged DIS w/ D2 using LAD @ Hall-C

- ✓ LAD to detect high-P spector proton
- ✓ Completed in mid 2025; Analyzing data now

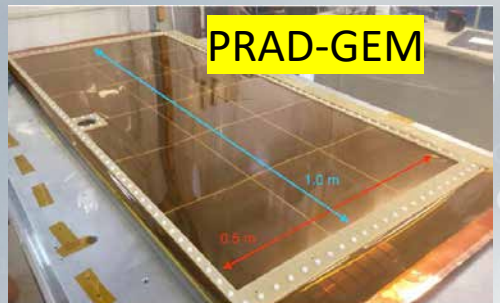
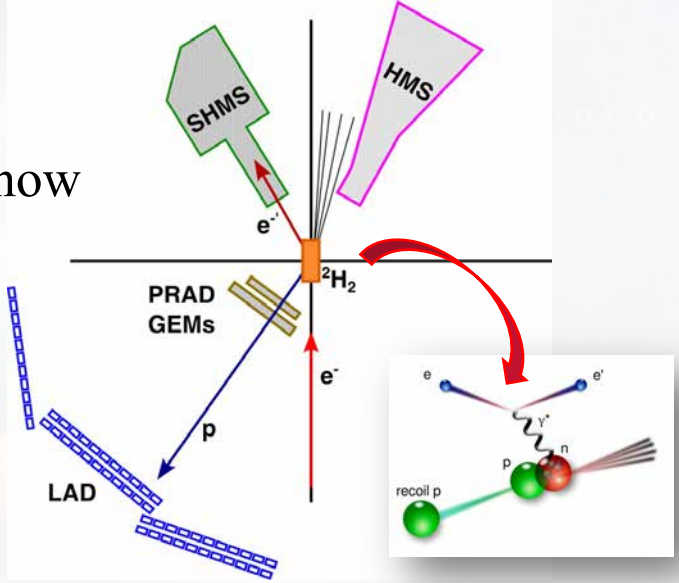

PRAD-GEM

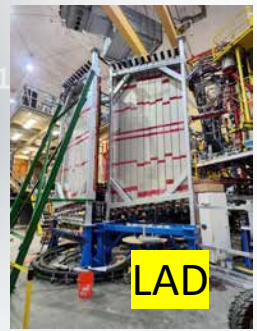

LAD

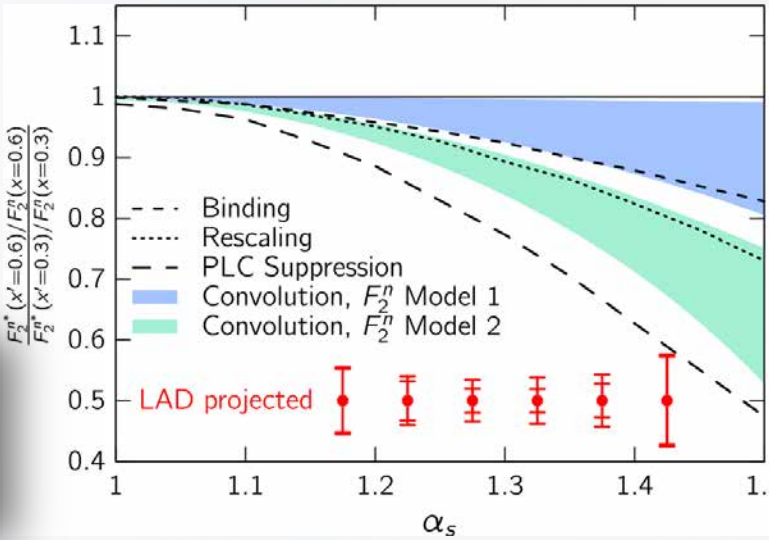

Transverse Momentum Distribution Functions (TMDs)

- ✓ 3D parton distribution in spatial space in momentum space
- ✓ Link to spin and orbital angular momenta
- ✓ 8 Leading Twist TMD, many more high-twist

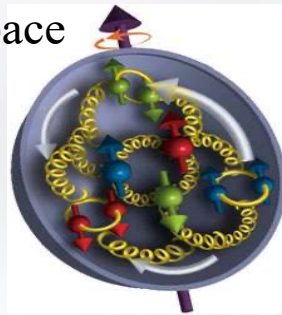

Semi-Inclusive Deep Inelastic Scattering (SIDIS)

- ✓ Beam &/ Target spin asymmetries link to TMD modules
- ✓ TMD & Fragmentation Function needed to decoupled

$$A_{UT}(\phi_h^l, \phi_S^l) = \frac{1}{P} \frac{N^\uparrow - N^\downarrow}{N^\uparrow + N^\downarrow}$$

$$= A_{UT}^{Collins} \sin(\phi_h + \phi_S) + A_{UT}^{Sivers} \sin(\phi_h - \phi_S)$$

$$+ A_{UT}^{Pretzelosity} \sin(3\phi_h - \phi_S)$$

UT: Unpolarized beam
+ Transversely polarized target

- Transversity $A_{UT}^{Collins} \propto \langle \sin(\phi_h + \phi_S) \rangle_{UT} \propto h_1 \otimes H_1^\perp$
- Sivers $A_{UT}^{Sivers} \propto \langle \sin(\phi_h - \phi_S) \rangle_{UT} \propto f_{1T}^\perp \otimes D_1$
- Pretzelosity $A_{UT}^{Pretzelosity} \propto \langle \sin(3\phi_h - \phi_S) \rangle_{UT} \propto h_{1T}^\perp \otimes H_1^\perp$
- Worm-Gear $A_{LT}^{Worm-Gear} \propto \langle \cos(\phi_h - \phi_S) \rangle_{LT} \propto g_{1T} \otimes D_1$

8 Quark-TMDs (leading twist)

Leading Twist TMDs	Quark Polarization		
	Unpolarized (U)	Longitudinally Polarized (L)	Transversely Polarized (T)
Nucleon Polarization	U $f_1(x, k_T^2)$ Unpolarized		$h_1^\perp(x, k_T^2)$ Boer-Mulders
	L $g_1(x, k_T^2)$ Helicity		$h_{1L}^\perp(x, k_T^2)$ Long-Transversity
Nucleon Polarization	T $f_{1T}^\perp(x, k_T^2)$ Sivers	$g_{1T}(x, k_T^2)$ Trans-Helicity	$h_1(x, k_T^2)$ Transversity $h_{1T}^\perp(x, k_T^2)$ Pretzelosity

$$f_1(x) = \int d^2k_\perp f_1(x, k_\perp)$$

$$g_1(x) = \int d^2k_\perp g_{1L}(x, k_\perp)$$

$$h_1(x) = \int d^2k_\perp [h_{1T}(x, k_\perp) + \frac{k_\perp^2}{2M^2} h_{1T}^\perp(x, k_\perp)]$$

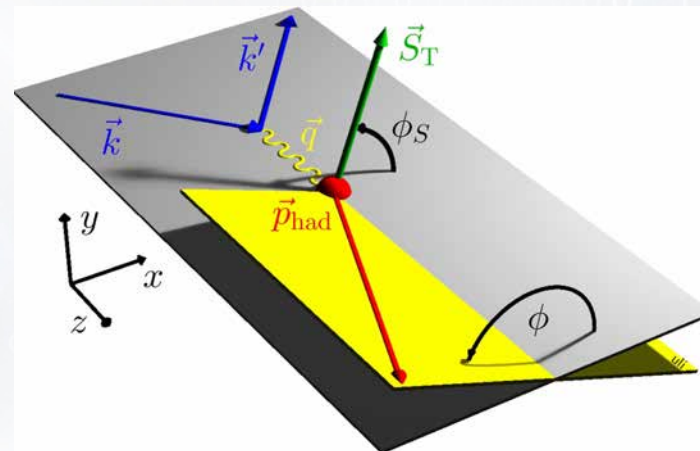

TMDs w/ CLAS12

10.6 GeV SIDIS in kaon production w/ polarized beam @CLAS12

✓ Map out z and P_T dependent in $F_{LU}^{\sin\phi}$ PRC, 112, 055202 (2025)

$$A_{LU}(z, P_T, x_B, Q^2, \phi) = \frac{d\sigma^+ - d\sigma^-}{d\sigma^+ + d\sigma^-} = \frac{A_{LU}^{\sin\phi} \sin\phi}{1 + A_{UU}^{\cos\phi} \cos\phi + A_{UU}^{\cos 2\phi} \cos 2\phi}$$

$$F_{LU}^{\sin\phi} = \frac{2M}{Q} \kappa \left[-\frac{\hat{h}k_T}{M_h} \left(xeH_1^\perp + \frac{M_h}{M} f_1 \frac{\tilde{G}^\perp}{z} \right) + \frac{\hat{h}p_T}{M} \left(xg^\perp D_1 + \frac{M_h}{M} h_1^\perp \frac{\tilde{E}}{z} \right) \right]$$

Twist-3 Boer-Mulder

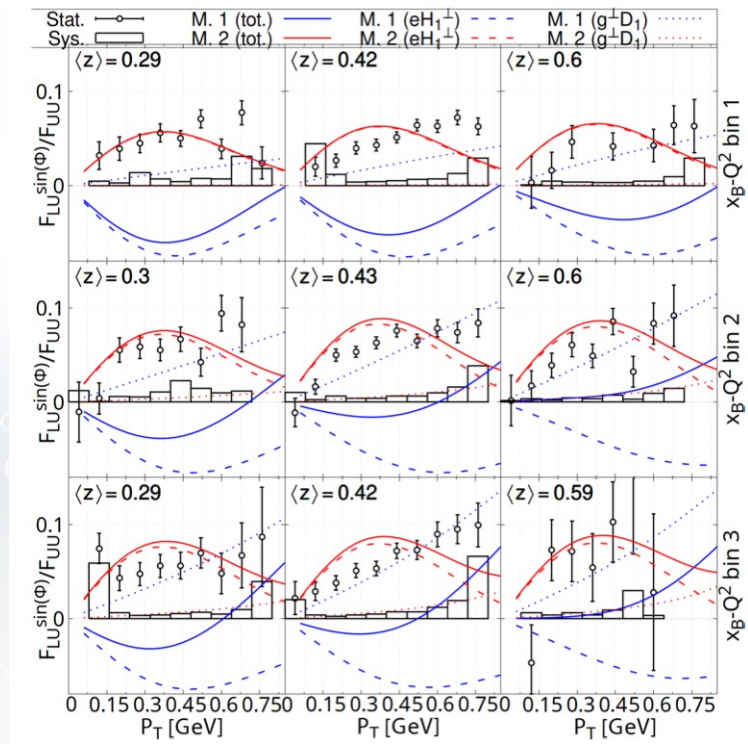

10.6 GeV SIDIS in di-pion production w/ polarized beam @CLAS12

✓ extract di-hadron fragmentation function & twist-PDF

$$A_{LU}^{\sin(m(\phi_h - \phi_{R_\perp}))} \propto f_1 \otimes G_1^\perp$$

DiFF arXiv:2602.1471

$$A_{LU}^{\sin(\phi_{R_\perp})} \propto \left[xe(x)H_1^\perp(z, M_h) + \frac{1}{z} f_1(x)\tilde{G}^\perp(z, M_h) \right]$$

Twist-3

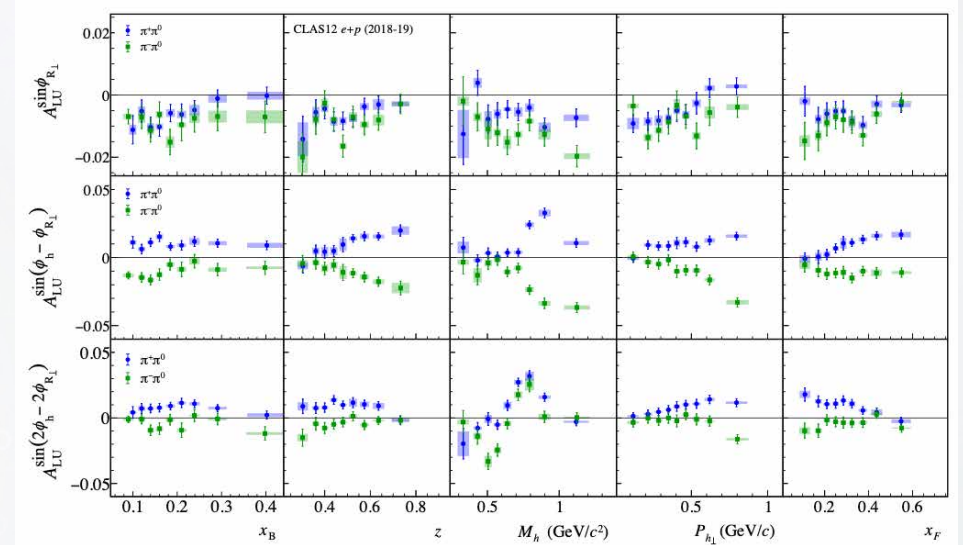

Future SIDIS w/ high-power polarized He3@CLAS12

(see Xiaqing Li's talk on Monday 5pm)

TMDs w/ SBS

Future SBS SIDIS E12-09-018 w/ polarized He3 & new RICH

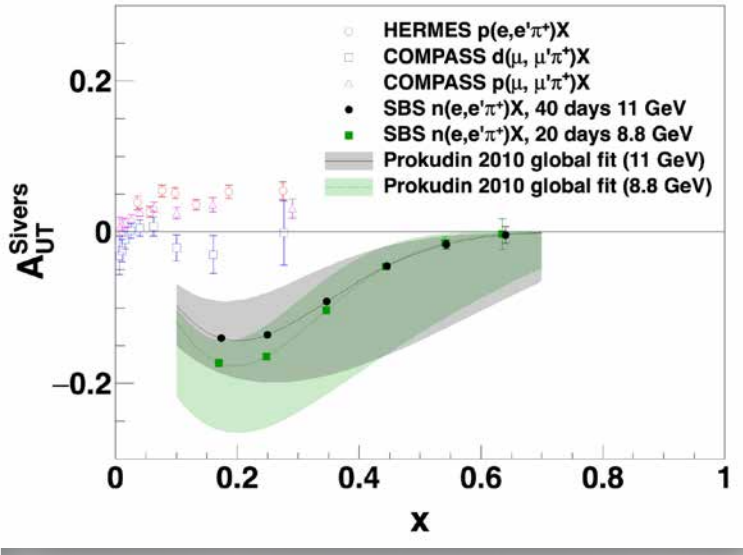
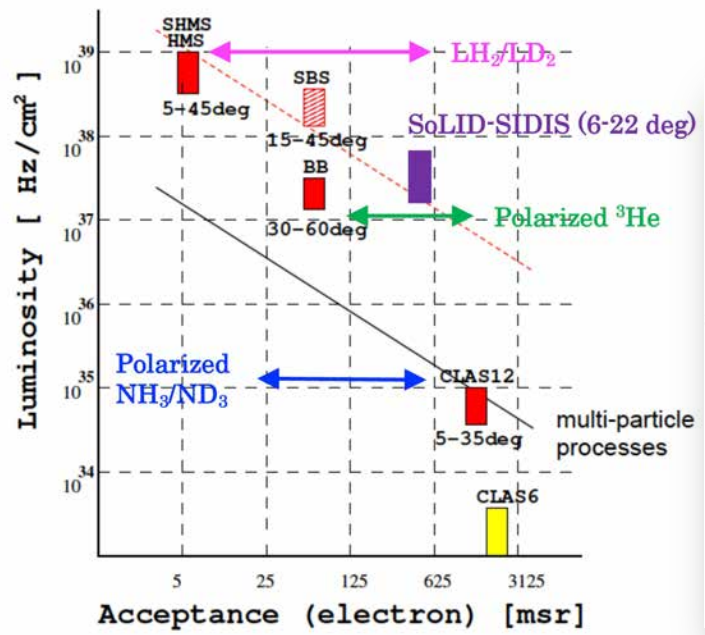
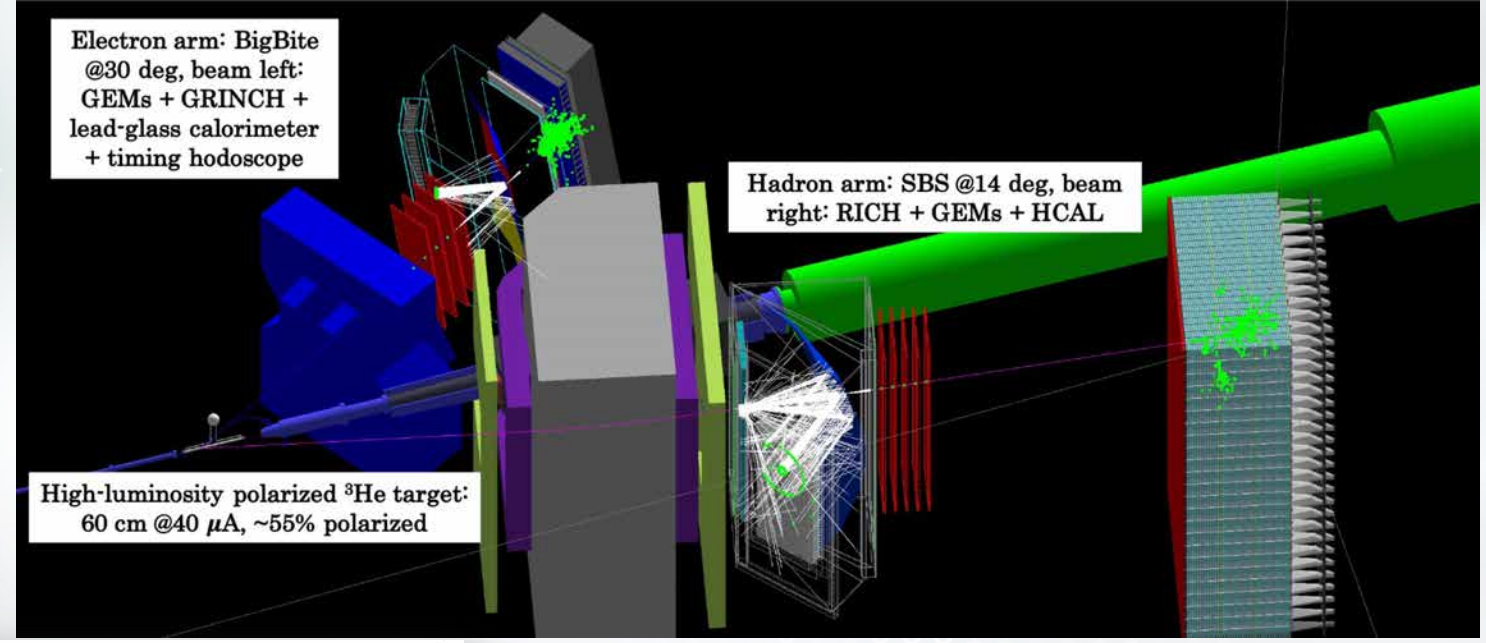

Shown is Mike Souza, our incenon glassblower, holding

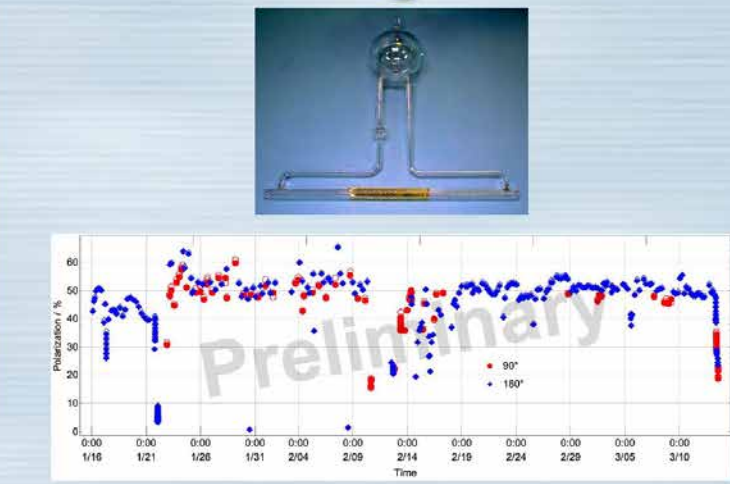

GPDs

Generalized Parton Distributions (GPDs)

- ✓ 3D parton distribution in spatial space
- ✓ 8 leading-twist GPDs

See X.D. Ji's talk on Wednesday

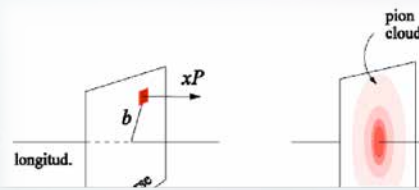

8 Quark-GPDs (leading twist)

		Quark Polarization		
		Unpolarized (U)	Longitudinally Polarized (L)	Transversely Polarized (T)
Nucleon Polarization	U	H		$2\tilde{H}_T + E_T$
	L		\tilde{H}	\tilde{E}_T
	T	E	\tilde{E}	H_T, \tilde{H}_T

Ji's Sum-Rule link GPD to nucleon spin:

$$J_{q/g} = \frac{1}{2} \int_{-1}^{+1} dx \cdot x [H^{q/g}(x, \xi, 0) + E^{q/g}(x, \xi, 0)] \quad (\text{X. Ji, PRL 78, 610 (1997)})$$

GPDs (in fact, Compton form-factors) are measured by exclusive processes:

$$e + N \rightarrow e' + N + \gamma$$

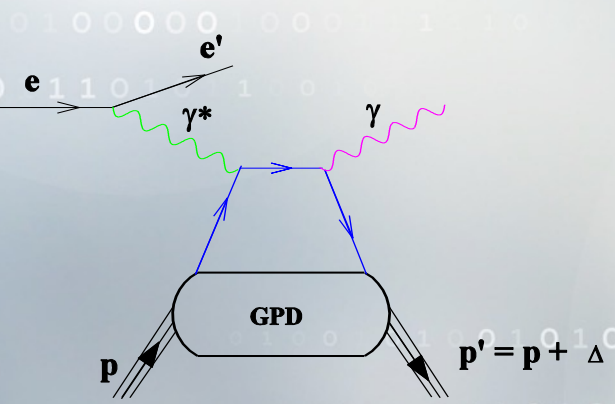

Deeply Virtual Compton Scattering (DVCS)

$$\gamma + N \rightarrow N + l^+ + l^-$$

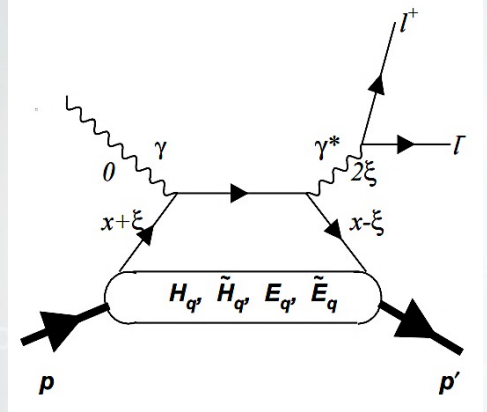

Timelike Compton Scattering (TCS)

$$e + N \rightarrow e' + N' + \text{Meson}$$

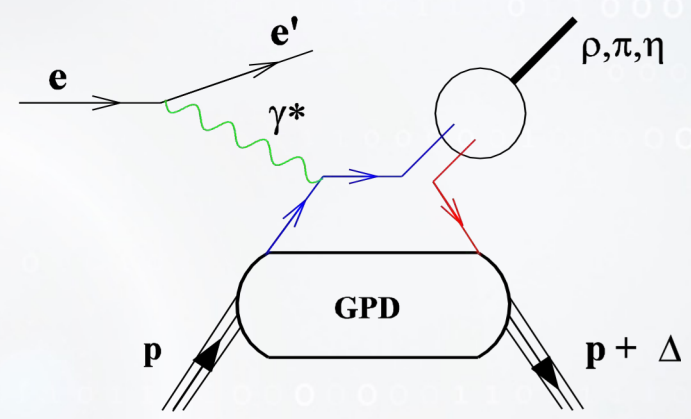

Deep Virtual Meson Production (DVMP)

$$e + N \rightarrow e' + N + l^+ + l^-$$

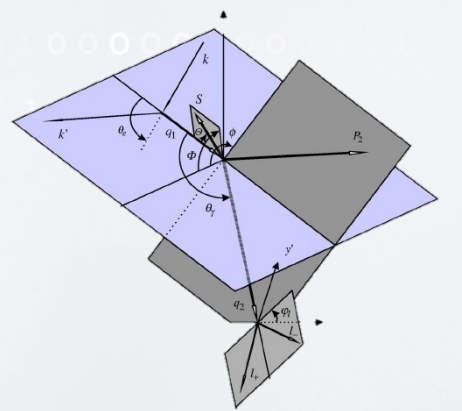

Double-DVCS (DDVCS)

GPDs /CLAS12

➤ First Neutron DVCS with CLAS12 central neutron detector

Phys. Rev. Lett.133, 211903 (Nov. 2024),

➤ ALERT measured DVCS/DVMP in He4

- 1 GPD in He4 (coherence DVCS)
- Nuclear-GPD in He4 (incoherence)
- RG-L (w/ tagged DIS & SRC)
- **Completed in 2025**, analyzing now



A view of the Central Neutron Detector in Hall B's CEBAF Large Acceptance Spectrometer for 12 GeV (CLAS12).

Accessing the Lesser-Known Nucleon

Protons and neutrons – known collectively as nucleons – are the building blocks of matter, but protons have received more attention in certain types of nuclear physics experiments. Until now, [New results published in Physical Review Letters](#) describe a first-time glimpse of the internal structure of the neutron thanks to the development of the Central Neutron Detector installed in Experimental Hall B's CLAS12 detector. To read the full story, [click here](#).

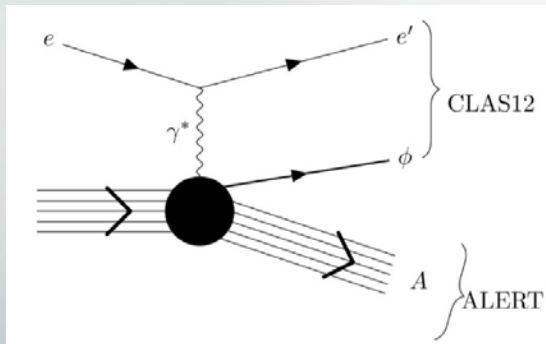
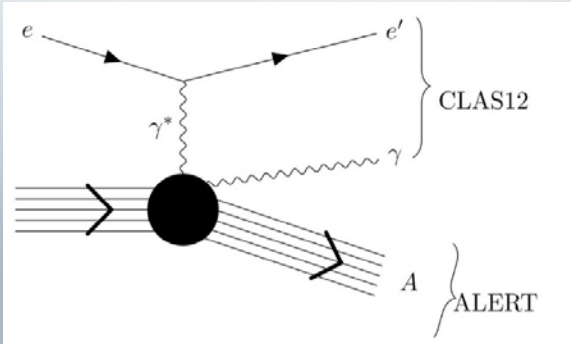
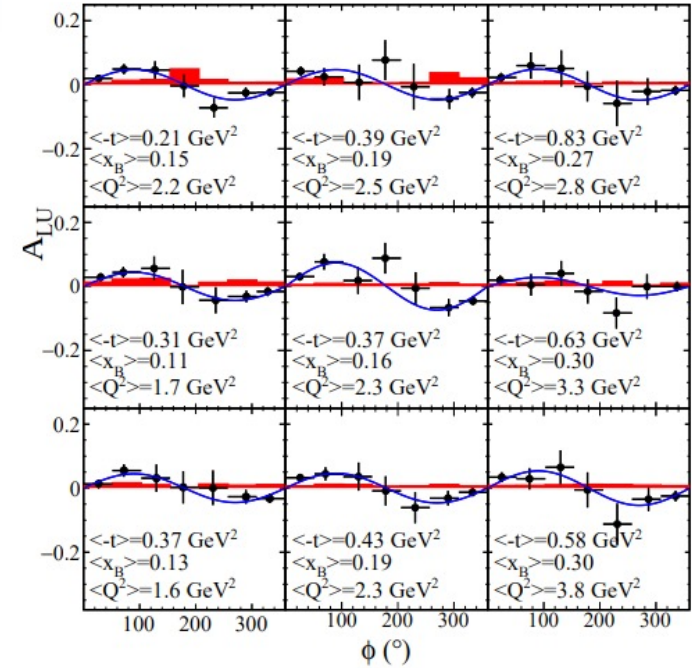

Eur. Phys. J. C manuscript No.
(will be inserted by the editor)

[arXiv:2503.18152](https://arxiv.org/abs/2503.18152)

Open database for GPD analyses

V.D. Burkert¹, A. Camsonne¹, P. Chatagnon^{1,2}, K. Cichy³,
M. Constantinou⁴, H. Dutrieux⁵, I. M. Higuera-Angulo¹, C. Mezrag²,
D. Richards¹, P. Sznajder⁶

➤ Global GPD analysis to extract proton property

GPDs w/ in Hall-C

□ PionLT/KaonLT Experiment in Hall C (completed in 2018):

- ✓ DVMP w/ π^+/K^+ to improve GPD models
($e + p \rightarrow e' + \pi^+/K^+ + n/\Lambda$)
- ✓ First extract of Q²-depd of σ_{LT}/σ_0 in asymmetries

$$A_{LU}(Q^2, x_B, t, \phi) = \frac{\sqrt{2\epsilon(1-\epsilon)} \frac{\sigma_{LT'}}{\sigma_0} \sin \phi}{1 + \sqrt{2\epsilon(1+\epsilon)} \frac{\sigma_{LT}}{\sigma_0} \cos \phi + \epsilon \frac{\sigma_{TT}}{\sigma_0} \cos 2\phi}$$

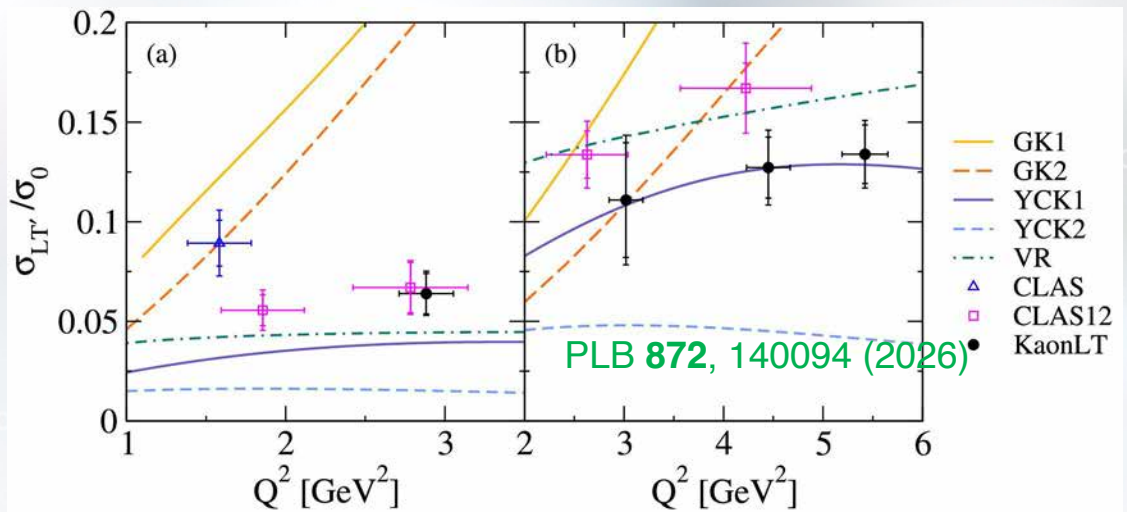

□ NPS Experiments (1st part completed in 2024):

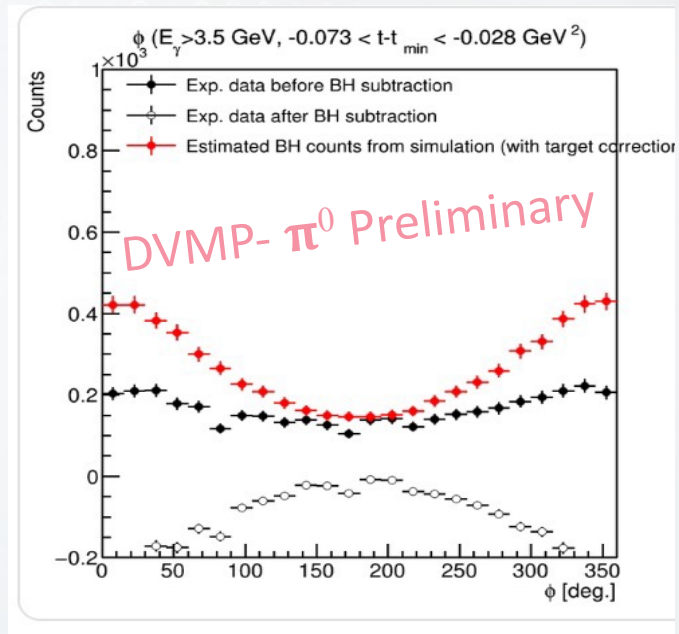
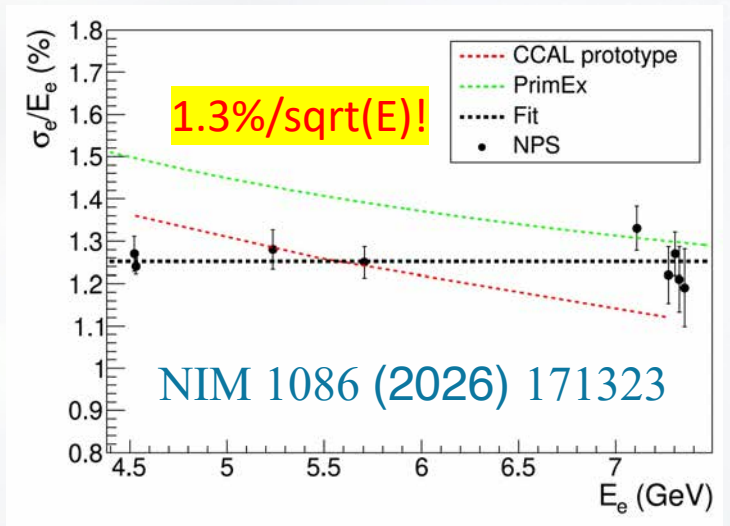
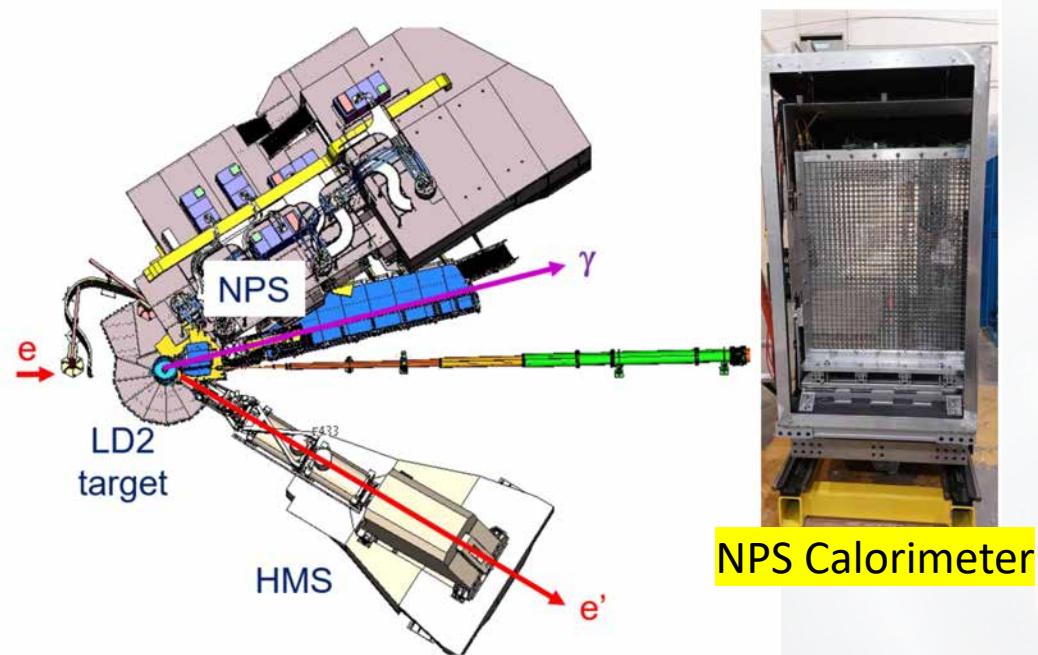

GlueX in Hall-D

□ $A(\gamma, J/\psi p)X$ reaction below threshold PRL 134 (2025) 201903,

▪ Modified of form factors & glue-density in nuclei due to SRC?

□ Next:

✓ JEF & PrimeX-eta

✓ KLF

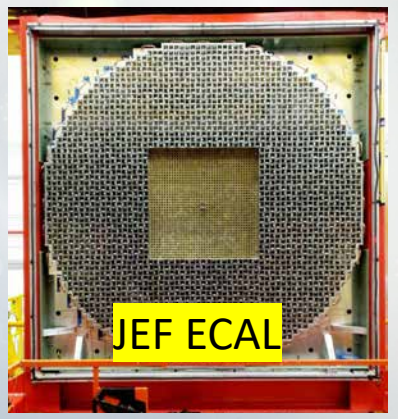

Experiment	name	Title	PAC rating	PAC days	data taken
E12-06-102	GlueX-I	Mapping the Spectrum of Light Quark Mesons and Gluonic Excitations with Linearly Polarized Photons	A	120	100%
E12-12-002	GlueX-II	A study of meson and baryon decays to strange final states with GlueX in Hall D	A	220	46%
	JEF	Eta Decays with Emphasis on Rare Neutral Modes: The JLab Eta Factory(JEF) Experiment	Grp	100	0%
E12-10-011	PrimeX- η	A Precision Measurement of the eta Radiative Decay Width via the Primakoff Effect	A-	79	100%
E12-13-008	CPP/NPP	Measuring the Pion Polarizability in the $\gamma\gamma \rightarrow \pi\pi$ Reaction	A-	25	100%
E12-19-003	SRC/CT	Studying Short-Range Correlations with Real Photon Beams at GlueX	B+	15	100%
<i>Not yet scheduled</i>					
E12-19-001	KLF	Strange Hadron Spectroscopy with Secondary KL Beam in Hall D	A-	200	
E12-20-011	REGGE	Measurement of the high-energy contribution to the Gerasimov-Drell-Hearn sum rule	A-	33	

- JEF: - considerable installation / new equipment required - fully budgeted, installation in progress
- KLF: - partly budgeted, design in progress
- REGGE: - not yet budgeted

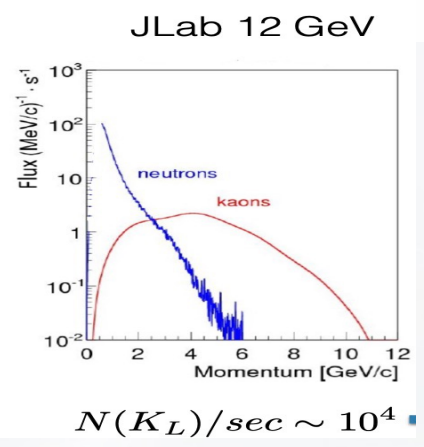
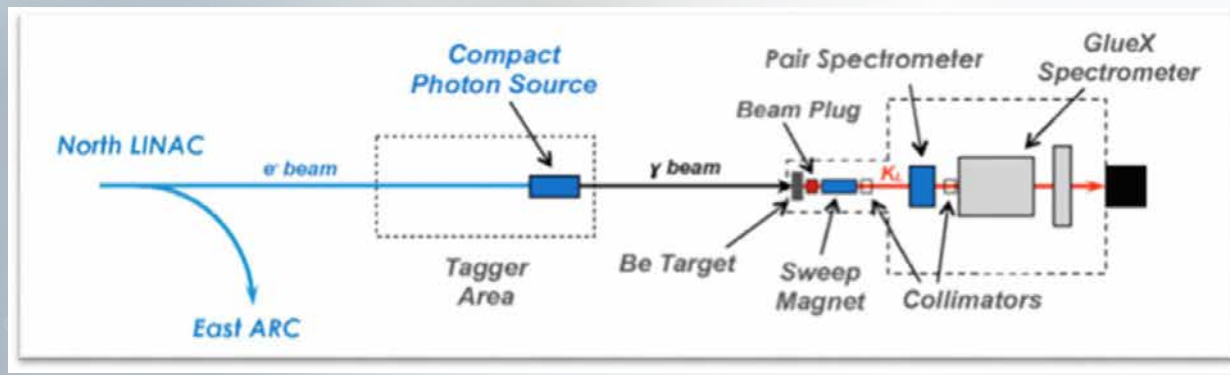
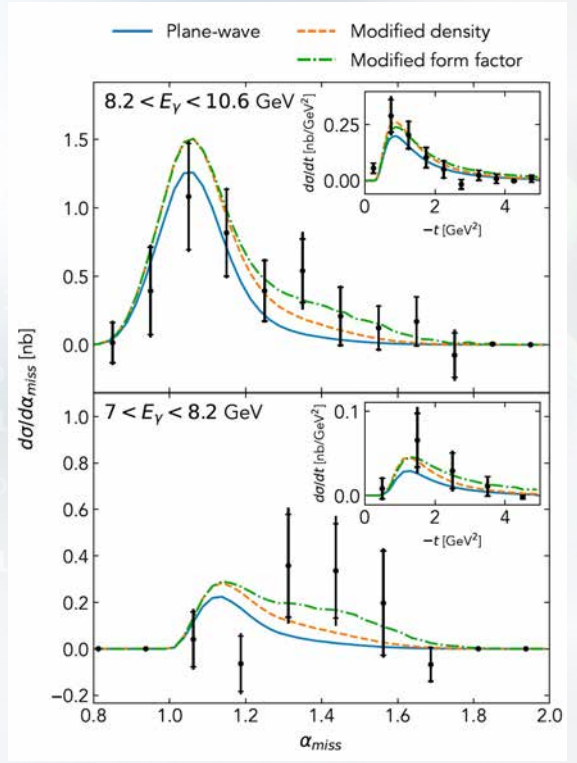

Future Upgrade-muCLAS12

- CLAS12 luminosity to be upgraded to $10^{37} \text{ cm}^{-2}\text{s}^{-1}$.
 - DC to muRWELL trackers
 - Add forward trackers
 - JLab to be MPGD Center in U.S.

➤ Enable the Doubly-DVCS measurements

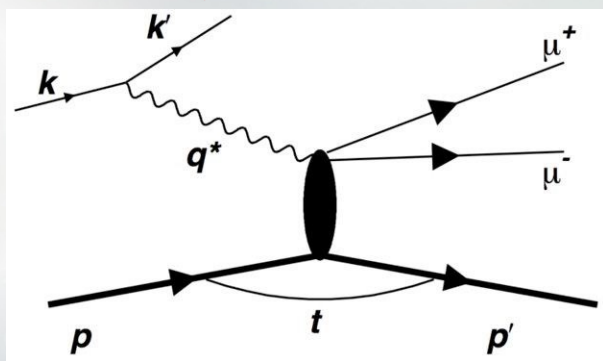

200 days to distinguish models at small-t region

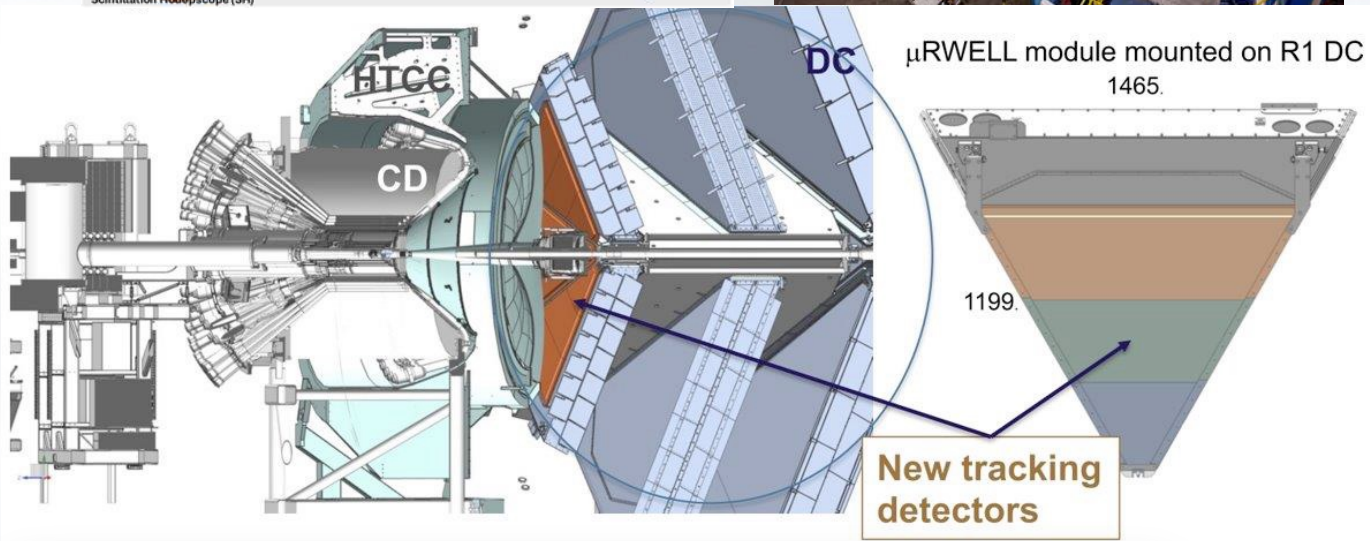
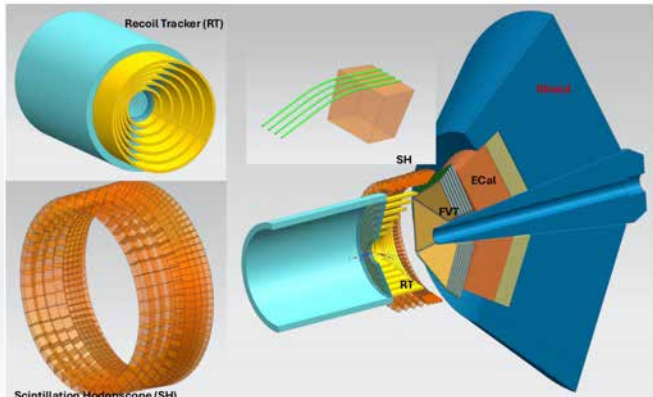
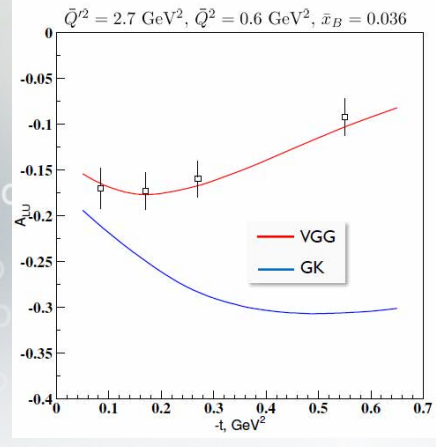
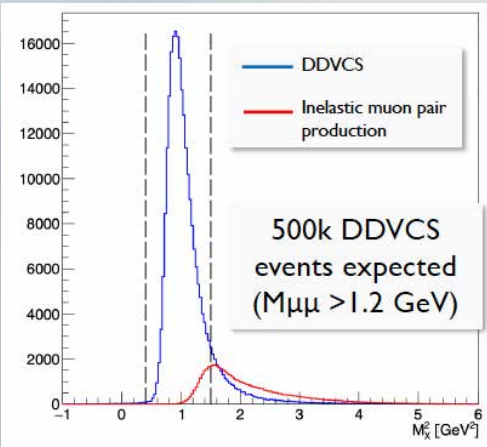

Electro- and photo-production of muon pairs with μ CLAS12: Double Deeply Virtual Compton Scattering, Timelike Compton Scattering, and J/ψ production

A Proposal to PAC 53

Future Upgrade-SoLID

➤ The Solenoidal Large Intensity Device SoLID):

- ✓ handle 10^{37} - 10^{39} $\text{cm}^{-2} \text{s}^{-1}$ luminosities
- ✓ full 2π azimuthal acceptance;
- ✓ Polarized p&n targets.

➤ Provide 4D/5D mappings of TMD & GPD; PVDIS for d/u & BSM

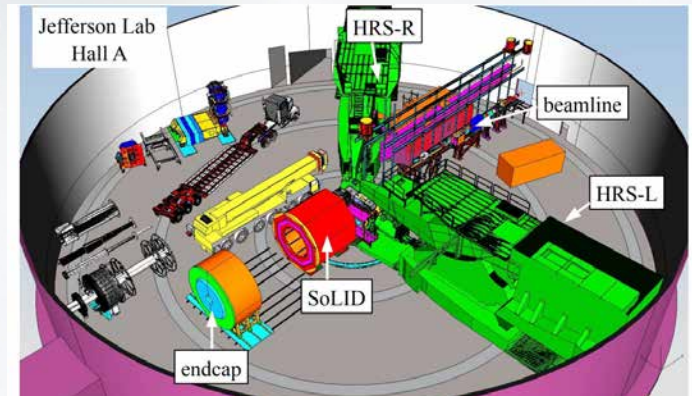
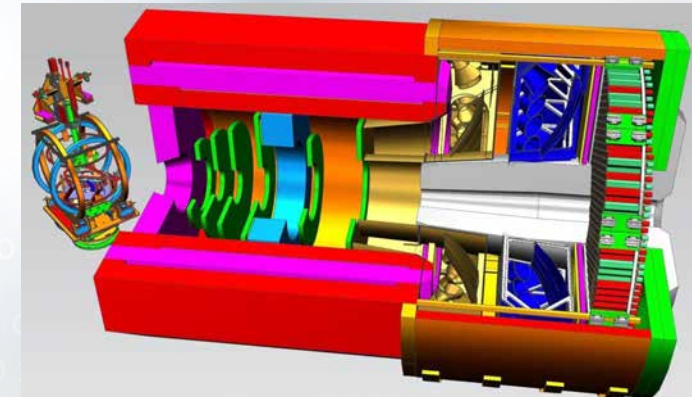
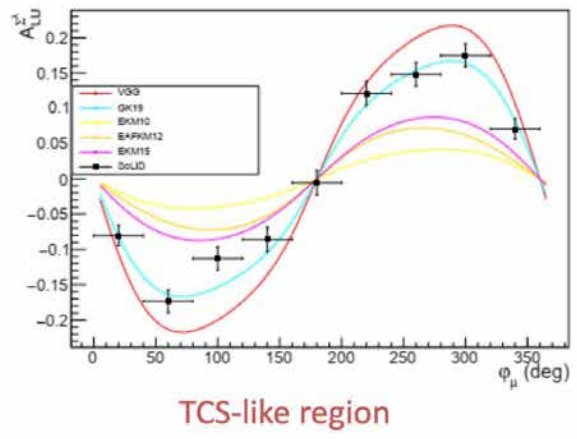
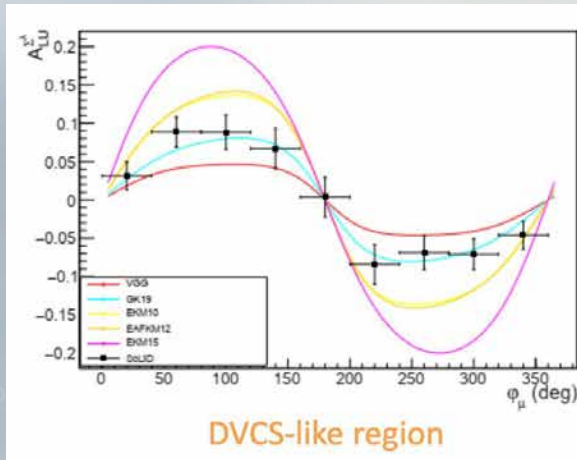
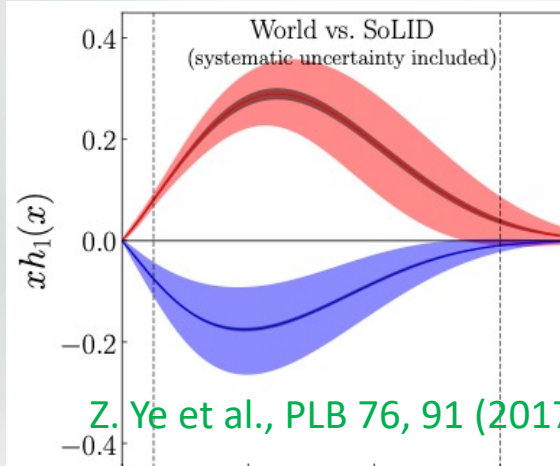
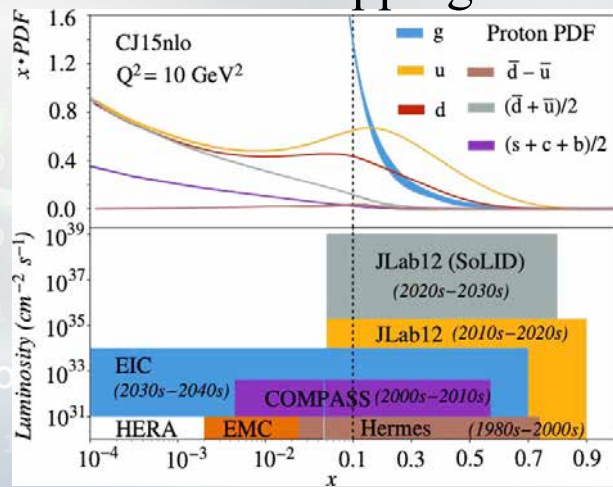

Future Upgrade-22GeV

- ❑ Fixed Field Alternating (FFA) gradient arcs to increase energy to 22 GeV

[Eur. Phys. J. A \(2024\) 60:173](#) [arXiv:2601.05773](#)

- ❑ Impact on Nucleon Structure:

- ✓ Expands DIS to higher Q^2
- ✓ Enlarge phase-space for TMD/GPD
- ✓ From valance quarks to sea
- ✓ Crosses charm threshold, gluonic GFFs and XYZ states
- ✓ EIC Synergy

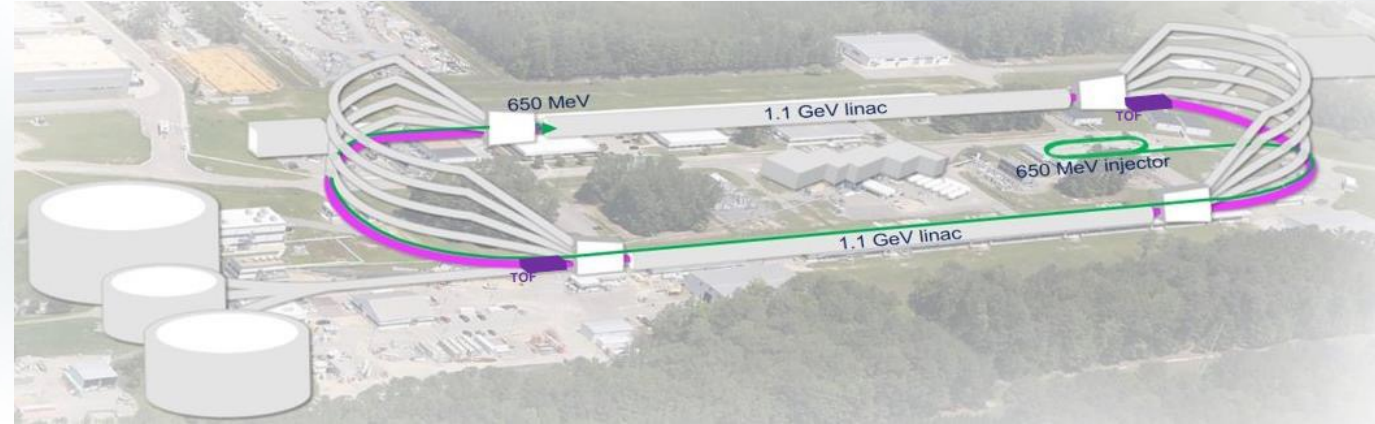

Collins SSA (SoLID@22GeV)

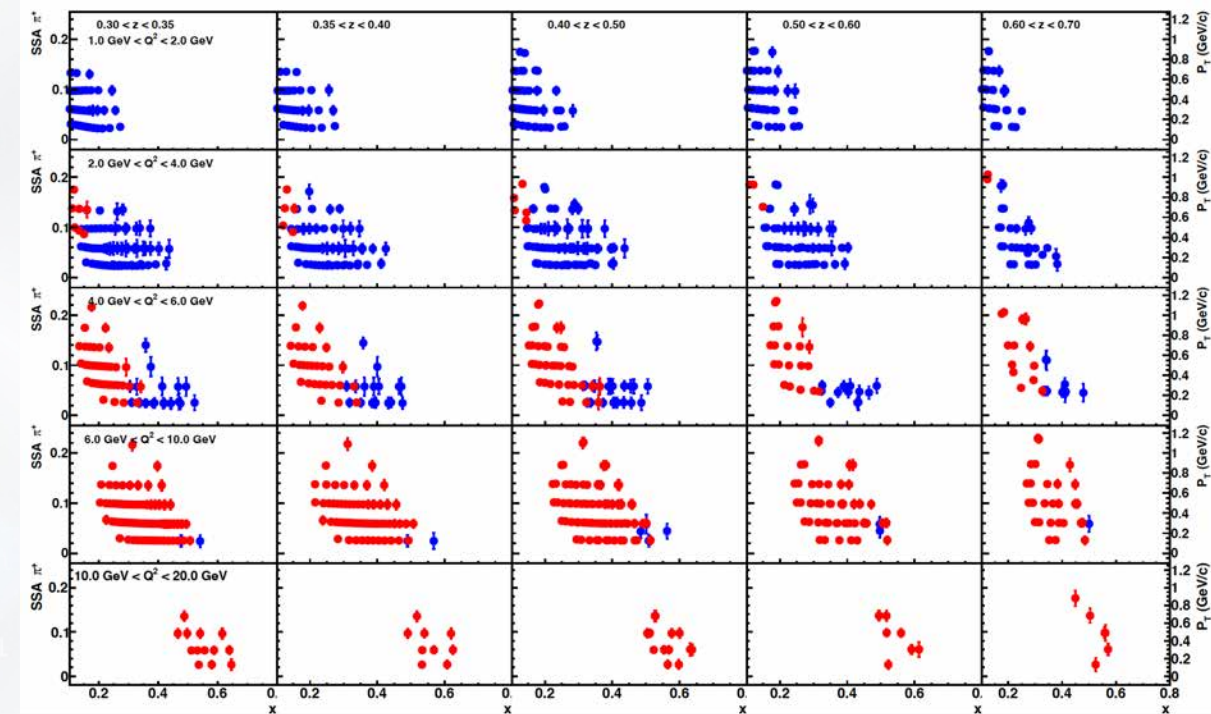
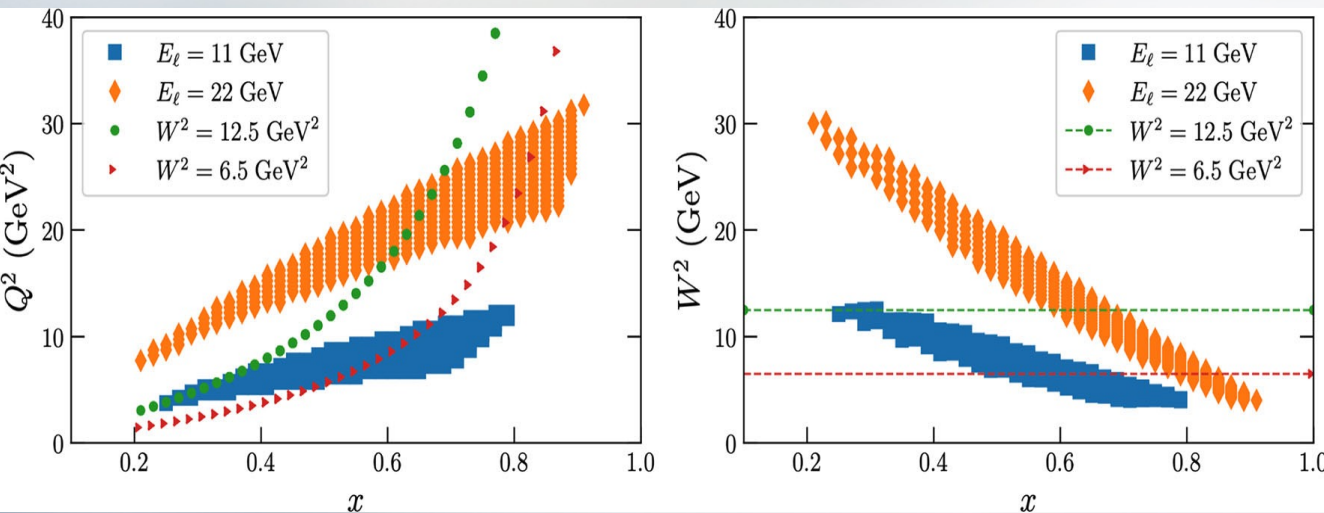

Near-Term Plans

☐ Successful CEBAF Operation in FY25 (22w Physics+2w Restore, >85% & 3000+hrs)

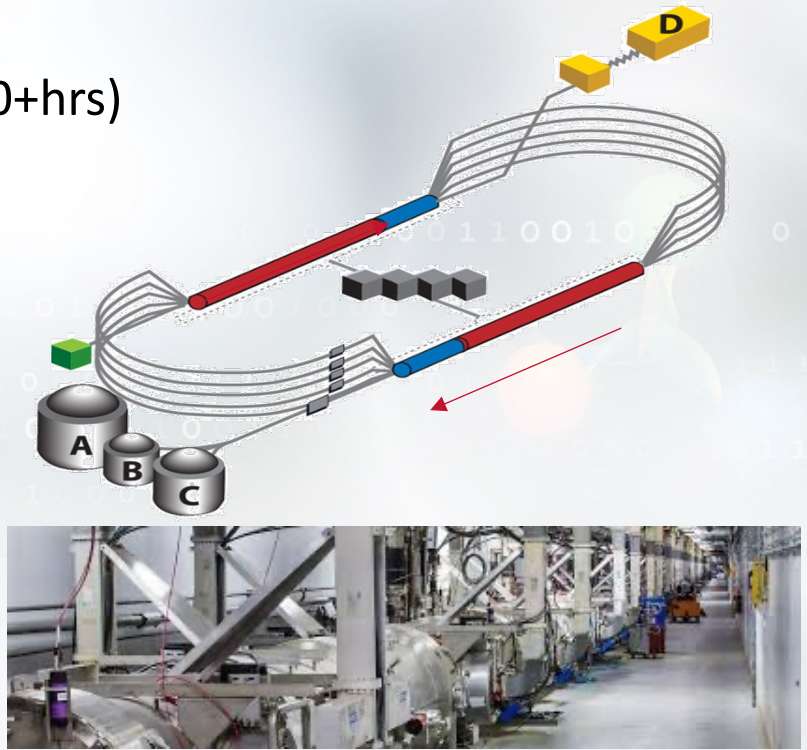
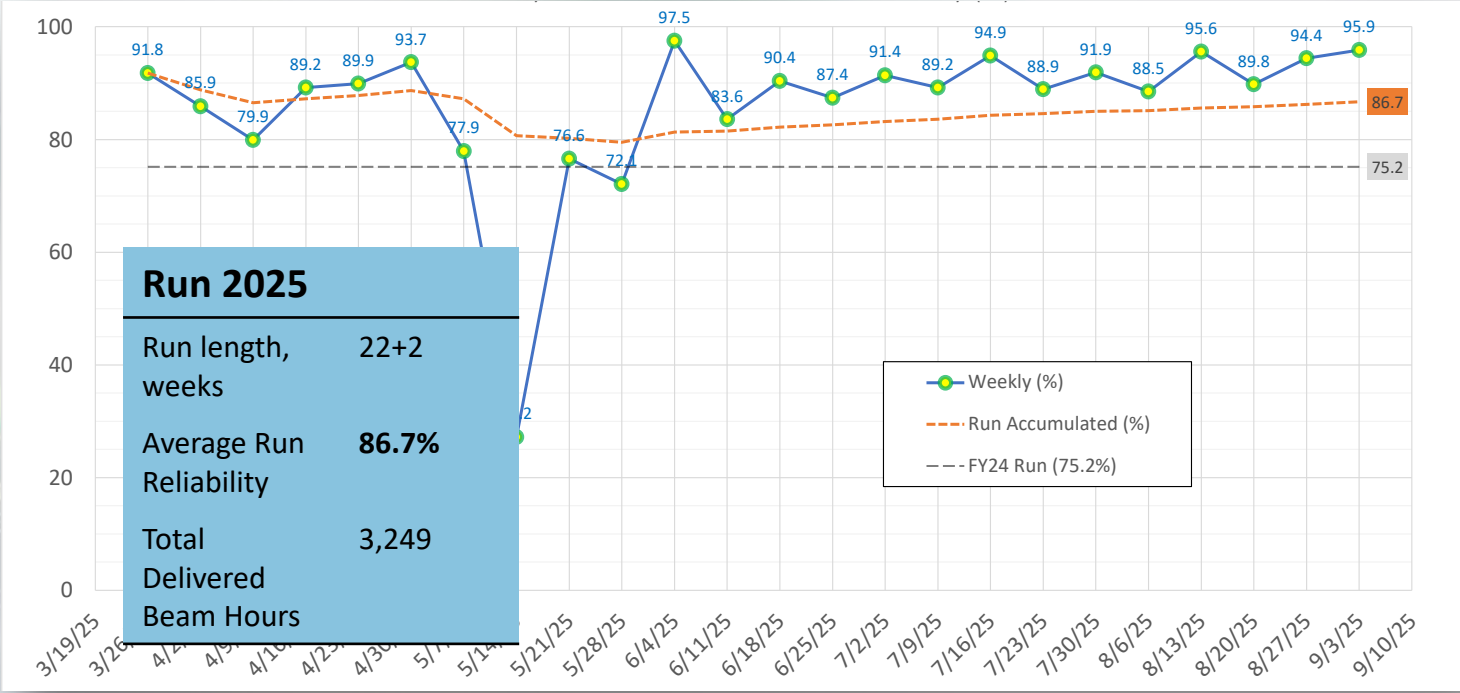

- ☐ Overcame longest government Shutdown
- ☐ Management Changes & Contract with SURA (06/01/2026)
- ☐ Staff Scientists layoffs (~7%)
- ☐ Budget cuts & AI GENESIS Initiative
- ☐ Transition to more applied tasks (e.g. HPDF)



D. Higinbotham (Jan. 2026 Hall-A Collaboration Meeting)

22/23

Experimental Hall A

E12-07-109: SBS Nuclear Form Factors (GEP-V)

MOLLER installation and testing

E12-09-005: MOLLER experiment

Next major installation

FY-2025

FY-2026

FY-2027

FY-2028

FY-2029

FY-2030

Experimental Hall B

Run Group L & E12-23-013: Tagged EMC Effect and SRC with ALLRI

E12-21-003 & 20-004: Hidden Sector New Particle X17 and Proton Radius

Run Groups C & G: 3D Imaging - polarized H & D & polarized EMC Effect

Run Group N: Polarized 3He SIDIS

Run Group H: 3D Imaging - Transverse Polarized Target

Run Group P: SIDIS with three body nuclei 3H and 3He

Experimental Hall C

E12-11-107: In Medium Nucleon Structure Functions with LAD

E12-06-104: I/T Separations in SIDIS

E12-06-107 Pion Color Transparency

E12-14-002: Nuclear R and E12-23-001 Polarizabilities

High luminosity cryotarget experiments

Hypernuclear installation

E12-15-008 and other Hypernuclear Experiments

Tensor Polarized Deuterium Target Installation

E12-13-011 & E12-15-005 DIS and QE Tensor Deuteron experiments

Experimental Hall D

GlueX Detector Upgrade

E12-12-002 & 12-002A: GlueX Phase II with DIRC and JFF

K_Long beam installation

E12-19-001: K_Long

Installation for GlueX Phase III

E12-24-006: GlueX Phase III

[Green bar]

[Hatched bar]

[Green bar]

[Green bar]

[Green bar]

[Green bar]

[Green bar]

[Green bar]

[Hatched bar]

SoLID?

FY25 Version of the CEBAF Long Term Tentative Schedule

PRAD-II&X17

SIDIS LT&R

JEF

K-LONG

Summary

- ❑ **Current Status:** Jefferson Lab retains its preeminence at the intensity frontier, successfully navigating the transition from 1D collinear densities to precision 3D tomographic measurements.
- ❑ **The Science Pipeline:** Emergent data from Hall-A (MARATHON, SBS), Hall-B CLAS12, and Hall-C (KaonLT, NPS, LAD) are resolving fundamental inquiries regarding the d&u PDF, the origins of the EMC effect, and explore TMD & GPD.
- ❑ **The Future Outlook:** muCLAS12, SoLID, and 22 GeV upgrade before EIC.

Backup



JLab Future?

- ❑ JLab Operation while constructing EIC:
 - Complete approved experiment → 2030~2035?
 - If SoLID approved → 2035~2040? [arXiv:2401.16223](https://arxiv.org/abs/2401.16223)
 - If Positron and/or 22GeV → 2045?

Activities	Fiscal Year																			
	24	25	26	27	28	29	30	31	32	33	34	35	36	37	38	39	40	41	42	
Moller (MIE, 413.3B, CD-2/3)	Active	Active	Active	Active	Active															
SoLID (LRP, Rec 4)			Active	Active	Active	Active	Active	Active												
Positron Source (R&D)	Active	Active	Active	Active	Active	Active	Active	Active												
CEBAF Upgrade <u>preCDR/preplan</u>	Active	Active	Active																	
Positron Project (potential)									Active	Active	Active	Active								
Transport e+													Active	Active	Active					
22 GeV Development (R&D)				Active	Active	Active	Active	Active	Active	Active	Active									
22 GeV Project (potential)												Active	Active	Active	Active	Active				
EIC Project (V4.2, CD-1, CD-3A)	Active	Active	Active	Active	Active	Active	Active	Active	Active	Active	Active									
CEBAF Up	Active	Active	Active	Active	Active	Active	Active	Active	Active	Active			Active	Active	Active				Active	

Quark PDFs at High-x

- Precision measurements of the F_2^n/F_2^p ratios to extract d/u at $x \rightarrow 1$;
 ✓ **Test QCD models!**

- Hall-A MARATHON utilized mirror ^3H and ^3He targets (done in 2017)

$$\frac{F_2^n}{F_2^p} = \frac{2\mathcal{R} - F_2^{^3\text{He}}/F_2^{^3\text{H}}}{2F_2^{^3\text{He}}/F_2^{^3\text{H}} - \mathcal{R}}$$

MARATHON, PRL128, 132003 (2022)

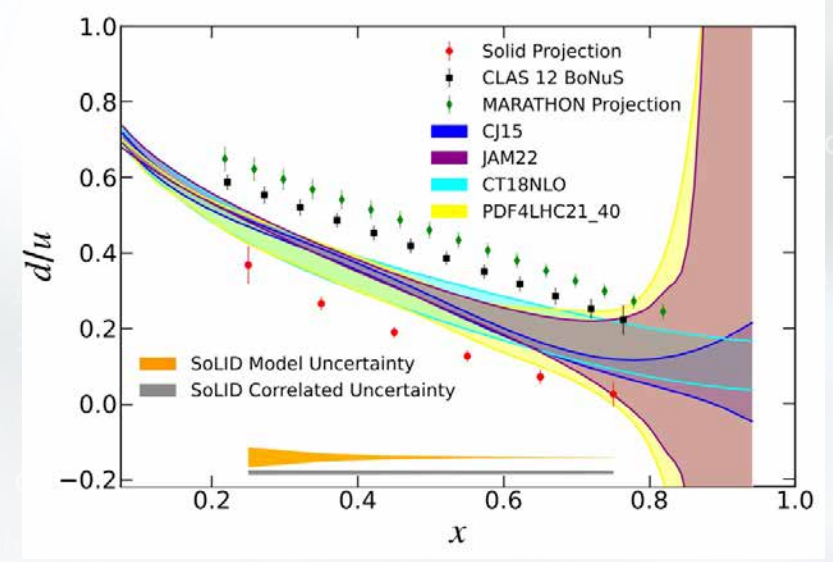
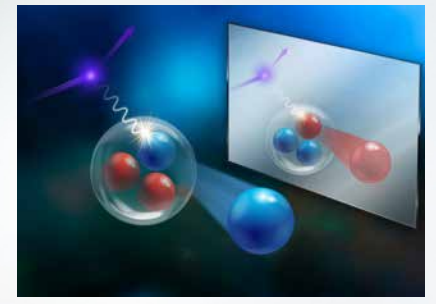

- Hall-B detector recoil proton from eD scattering (BoNUS+CLAS);

- New data in 2020 w/ BoNUS12 + CLAS12
 → published soon

- Future: PVDIS w/ SoLID

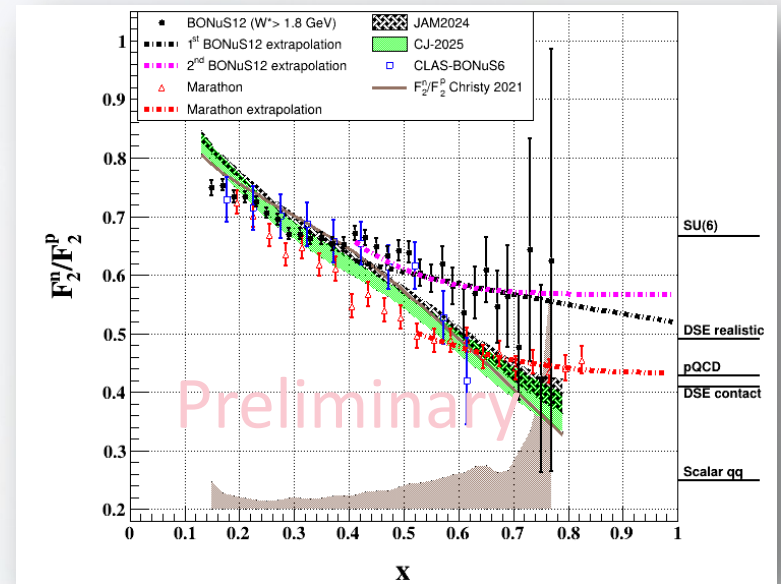
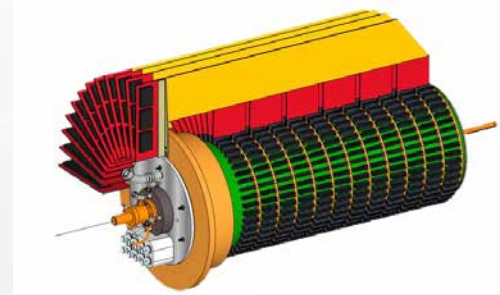
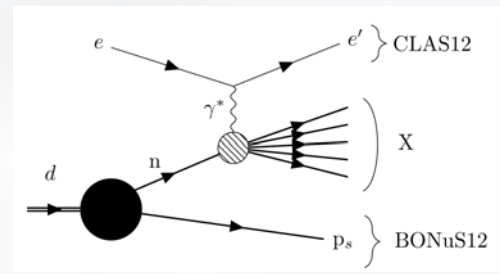

Meson Structure in Hall-C

□ Partonic structure in meson: critical to understand EHM mechanisms

- ✓ Sullivan process to scattering meson cloud
- ✓ L/T separation from KaonLT data → Kaon FF

$$\sigma_L \approx \frac{-tQ^2}{(t - m_K^2)^2} g_{KNN}^2(t) F_K^2(Q^2, t)$$

$$2\pi \frac{d^2\sigma}{dt d\phi} = \varepsilon \frac{d\sigma_L}{dt} + \frac{d\sigma_T}{dt} + \sqrt{2\varepsilon(\varepsilon+1)} \frac{d\sigma_{LT}}{dt} \cos \phi + \varepsilon \frac{d\sigma_{TT}}{dt} \cos 2\phi$$

□ **Rosenbluth Separation:** fix Q^2 and x , measure ε

- In SIDIS, fix z and P_{hT} as well!
- High-precision needed in beam-energy, spectrometer's momentum and angle!

$(e + p \rightarrow e' + \pi^+ / K^+ + n / \Lambda)$

