

PSI Center for
Photon Science

Developments of Hybrid Pixel Detector for Photon Science at PSI

Xiangyu Xie :: Postdoc :: Center for Photon Science
xiangyu.xie@psi.ch
ShanghaiTech University 2026.04.17

Paul Scherrer Institute



Part of the domain of the Swiss Federal Institutes of Technology

- Large scale facilities
- Largest research institute in Switzerland
- ~2300 Employees

X-ray Free Electron
Laser SwissFEL

Synchrotron radiation
Swiss Light Source

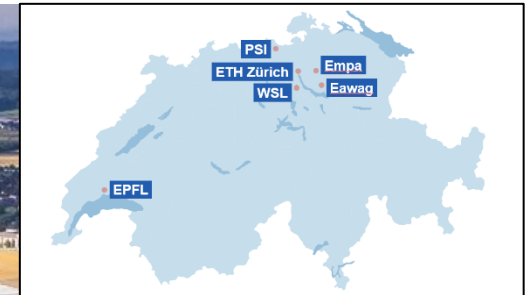

Paul Scherrer Institute



Part of the domain of the Swiss Federal Institutes of Technology

- Large scale facilities
- Largest research institute in Switzerland
- ~2300 Employees



X-ray Free Electron
Laser SwissFEL

Synchrotron radiation
Swiss Light Source2.0



Detector Challenges

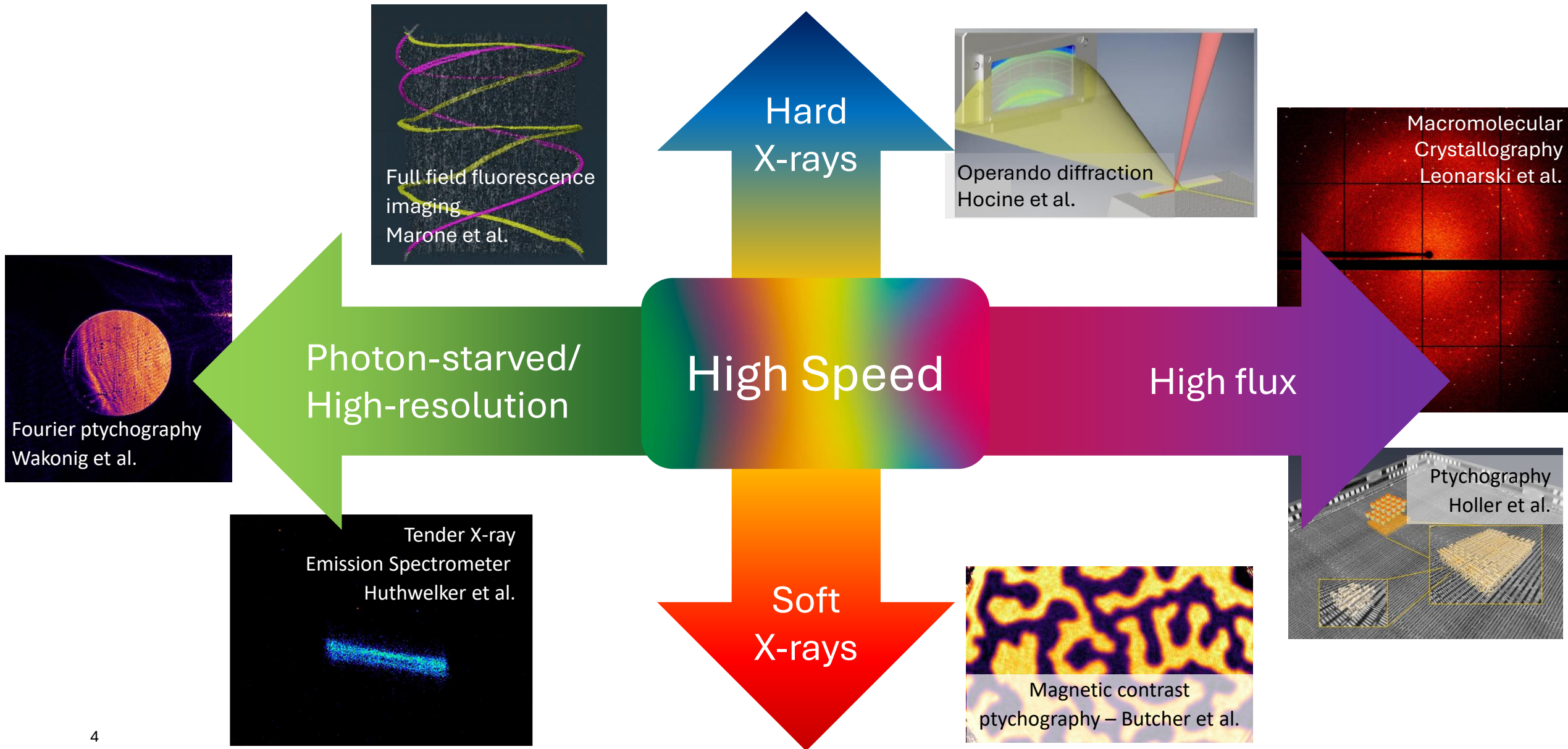

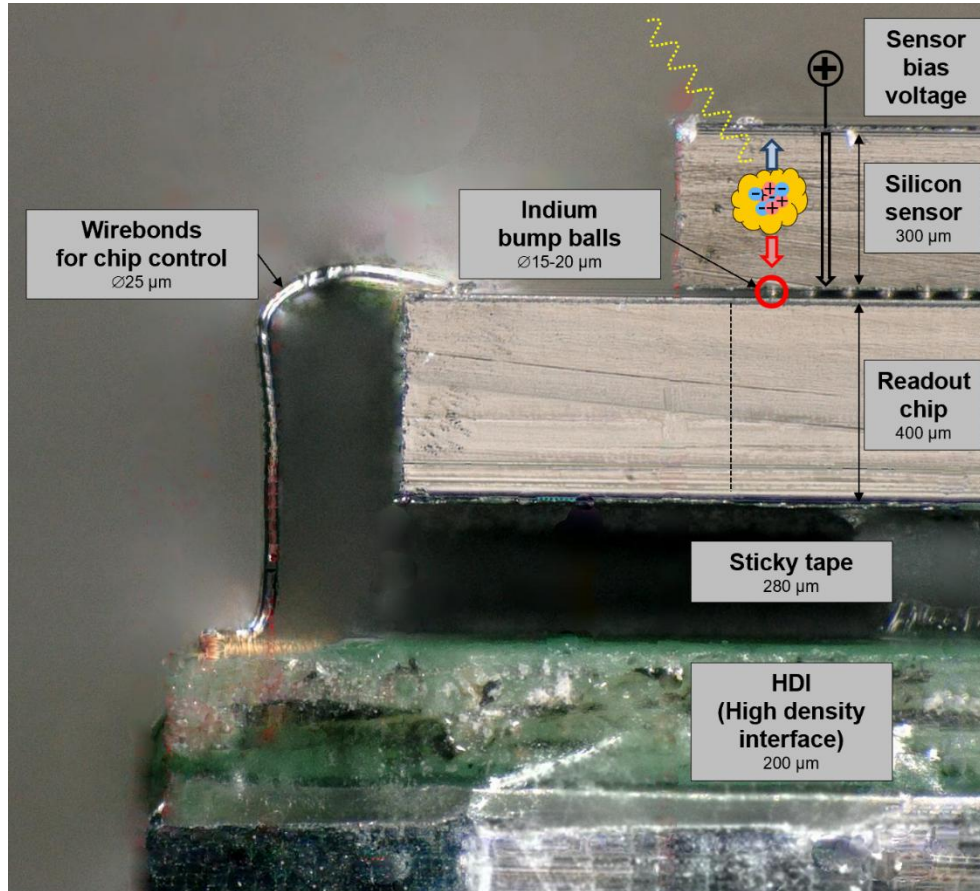

Semiconductor sensor

- Direct conversion

Versatile CMOS readout chip

- Fast readout
- Radiation hardness

Bump bonding

- Flexible combination of chips and sensors
- Noise due to input capacitance

Large area by tiling

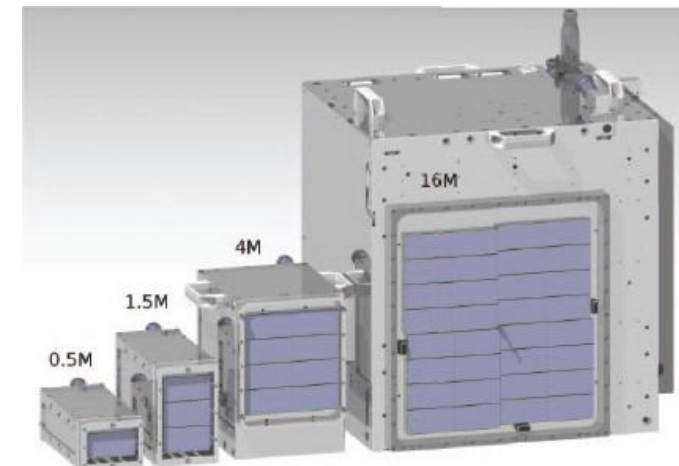

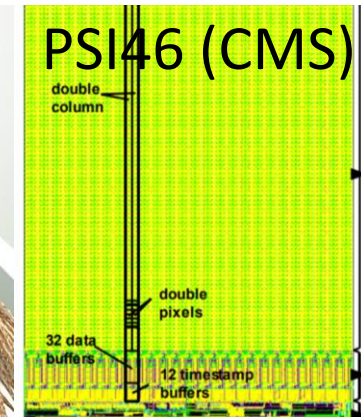
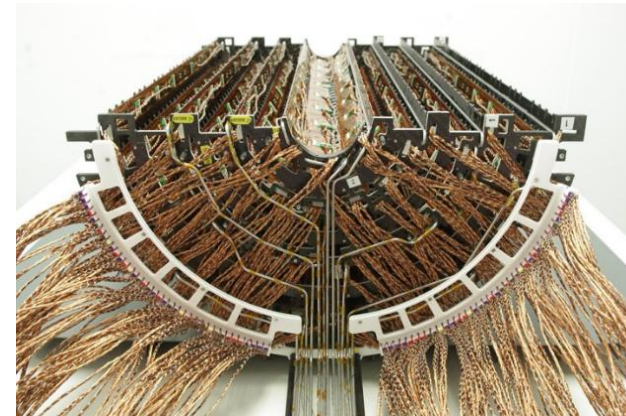
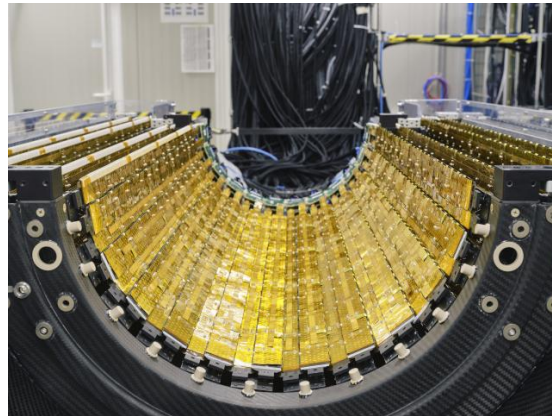

Developments at CERN

1996: Prototyped by M. Campbell etc.

- Spined off Medipix group
- Adapted to Medipix1 for medical imaging

Since 2000s: **Medipix** (energy resolving) and **Timepix** (fast timing) series

- Licensed to various companies: ADVACAM, Quantum Detectors etc.

Developments at PSI

1996: Prototyped by R. Horisberger etc.

- Spined off Photon Science Detector Group
- Adapted to PILATUS1 for photon science

Since 2000s: a series of **single photon counting** and **charge-integrating** detectors

- **Revolutionized** X-ray applications
- Spined off Dectris LTD

Center for Photon Science Detector Group





Develop detectors for the SLS and SwissFEL

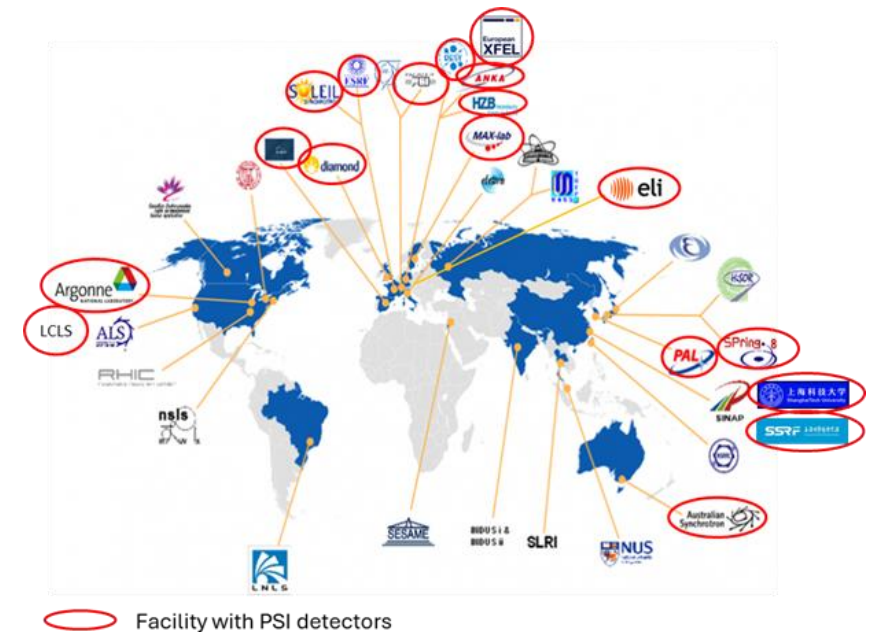
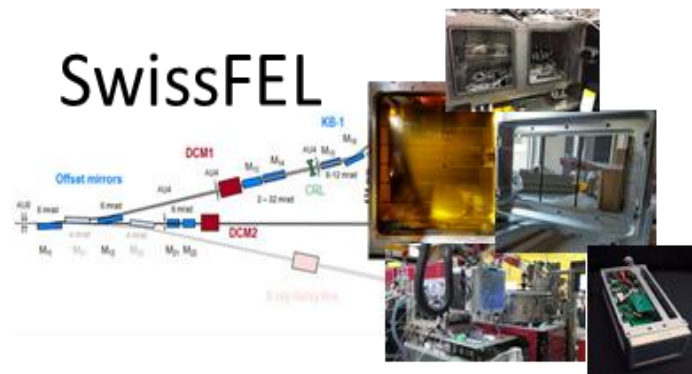
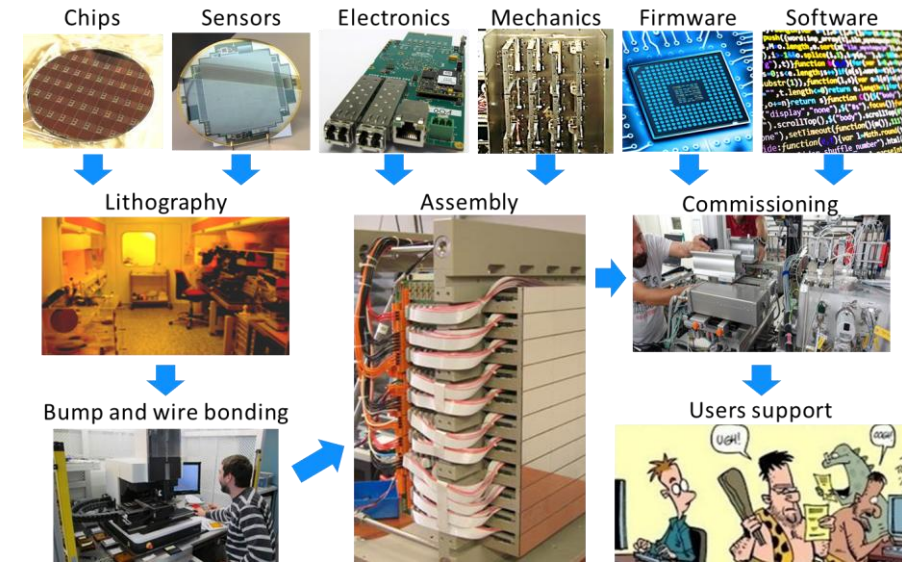

- Detector R&D
- Chip/Sensor design and detector production
- Characterization and commissioning

Extending detector applications

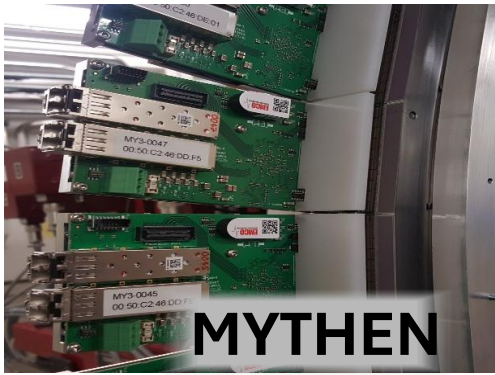
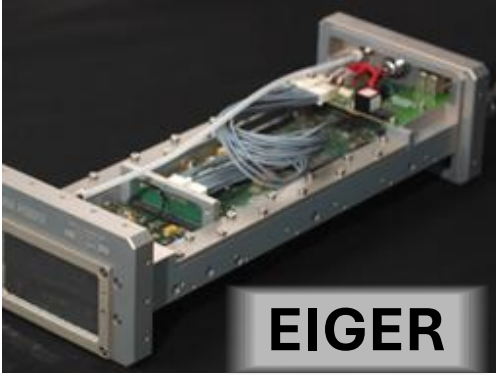
- Ultrafast Electron Diffraction
- Electron Microscopy

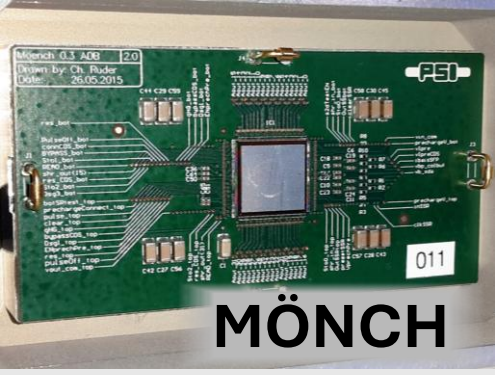

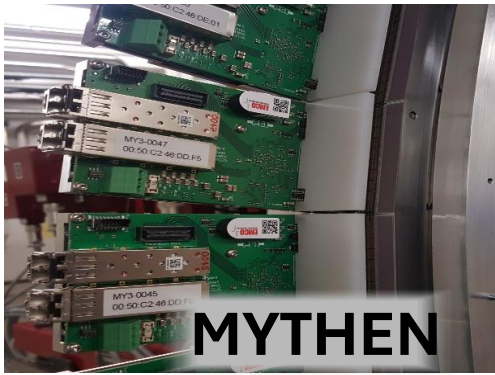
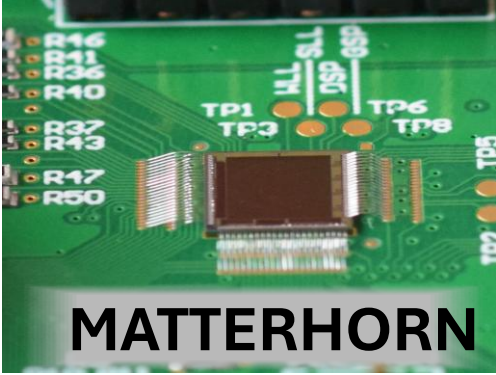
	Microstrip 1D	Pixel 2D	
	25/50 μm pitch	75 μm pitch	25 μm pitch
Single photon counting	 <p>MYTHEN</p>	 <p>EIGER</p>	
Charge integrating	 <p>GOTTHARD</p>	 <p>JUNGFRAU</p>	 <p>MÖNCH</p>

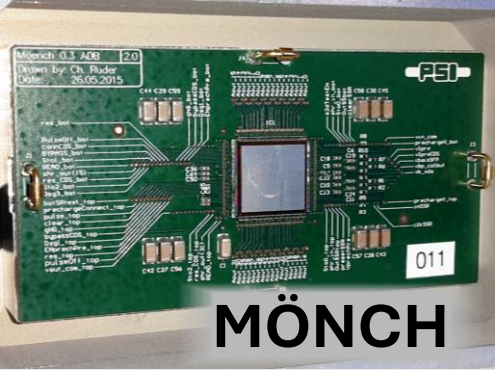
	Microstrip 1D	Pixel 2D	
	25/50 μm pitch	75 μm pitch	25 μm pitch
Single photon counting	 <p>MYTHEN</p>	 <p>MATTERHORN</p>	
Charge integrating	 <p>GOTTHARD</p>	 <p>JUNGFRAU</p>	 <p>MÖNCH</p>

MATTERHORN: the Next Peak for Single Photon Counting For 4th Generation Synchrotrons



	EIGER	MATTERHORN
Pixel size	75x75 μm^2	
Module size	4x8 cm^2	
Thresholds	1	4
Min Threshold	~ 3 keV	~ 1.5 keV
Counter depth	12 bit	4 x 16 bit
Max. Frame rate	10 kHz (burst, 8 bit)	20 kHz (continuous)
Count rate (90% efficiency)	0.35 Mcounts/pixel/s	20 Mcounts/pixel/s
Gating	~ 1 x μs	~ 4 x 20 ns

Characterization in progress

- Count rate capability **>7.5 MHz** (3 counters)
- Below expectation, to be tuned and optimized

Fast, operando, time resolved imaging and diffraction applications

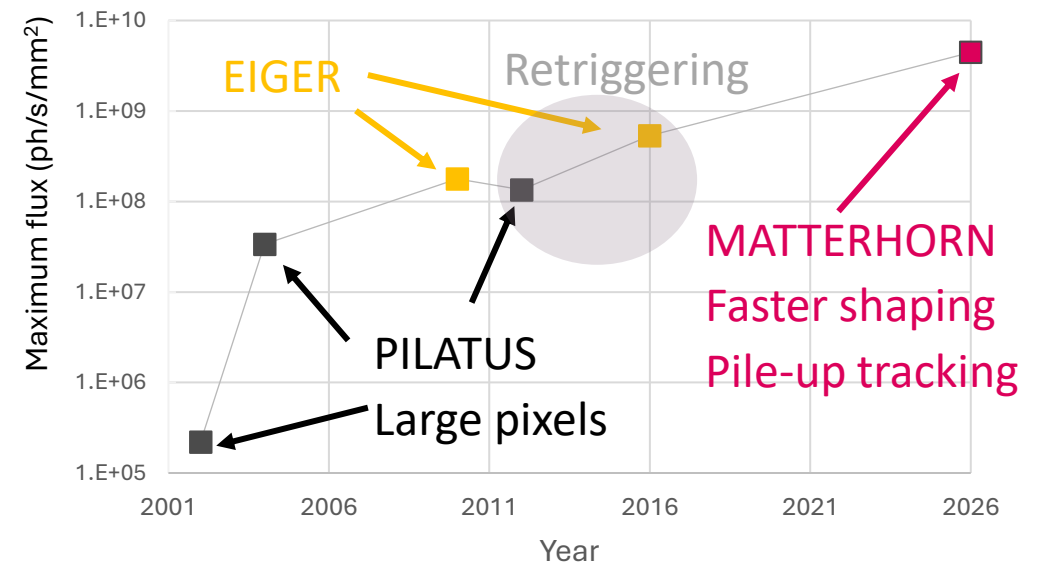
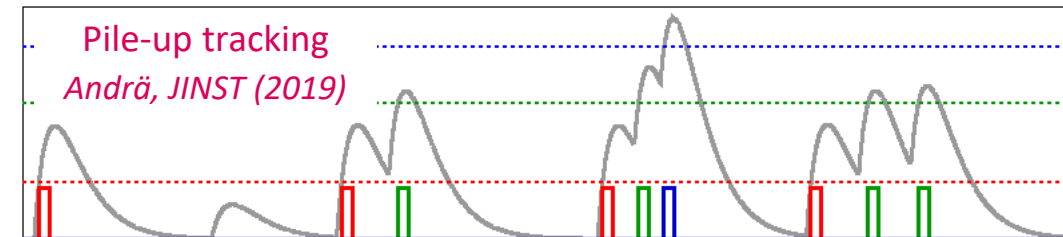

10 MATTERHORN systems planned for SLS2.0 (>50M pixels)

JUNGFRAU: Charge-integrating Detector with Dynamic Gain Switching for Free Electron Lasers

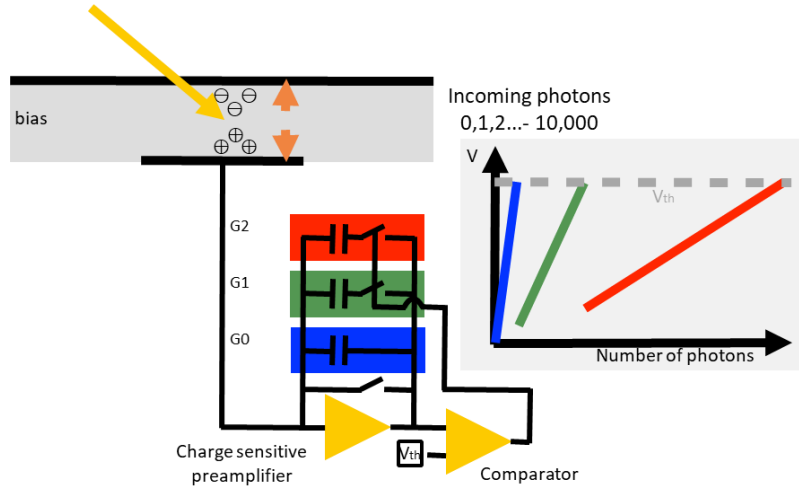

Challenge: too many photons in one pulse

Solution: charge-integrating + dynamic gain switching

- Automatically add capacitors to extend the dynamic range
- Noise remains below Poisson statistical limit
- **Single photon resolution and large dynamic range**

No efficiency loss due to corner effect

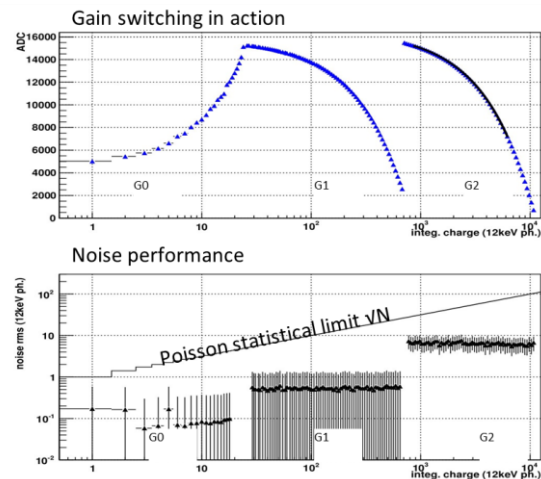

Single photon counting equivalent data quality!

EIGER loses efficiency in the corner of pixels →
JUNGFRAU provides better data quality

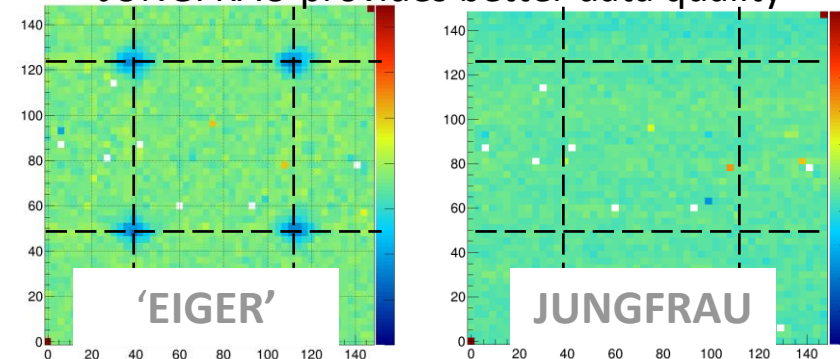

20 keV pencil beam scans

>30 JUNGFRAU systems (>140M pixels) installed in >11 facilities

JUNGFRAU2: Faster, even Higher Intensities



	JUNGFRAU	JUNGFRAU2
Pixel size	75x75 μm^2	75x75 μm^2 Rebin-able
Module size	4x8 cm^2	4x8 cm^2
Dynamic range (12 keV)	10^4	10^4
Min Energy*	~ 800 eV	~ 600 eV
Max Frame rate	2.2 kHz	10 kHz
Max count rate (12 keV)	22 Mcounts/pixel/s	100 Mcounts/pixel/s
Storage cells (burst mode)	16	16 Rebin-able

* with single photon resolution, standard silicon

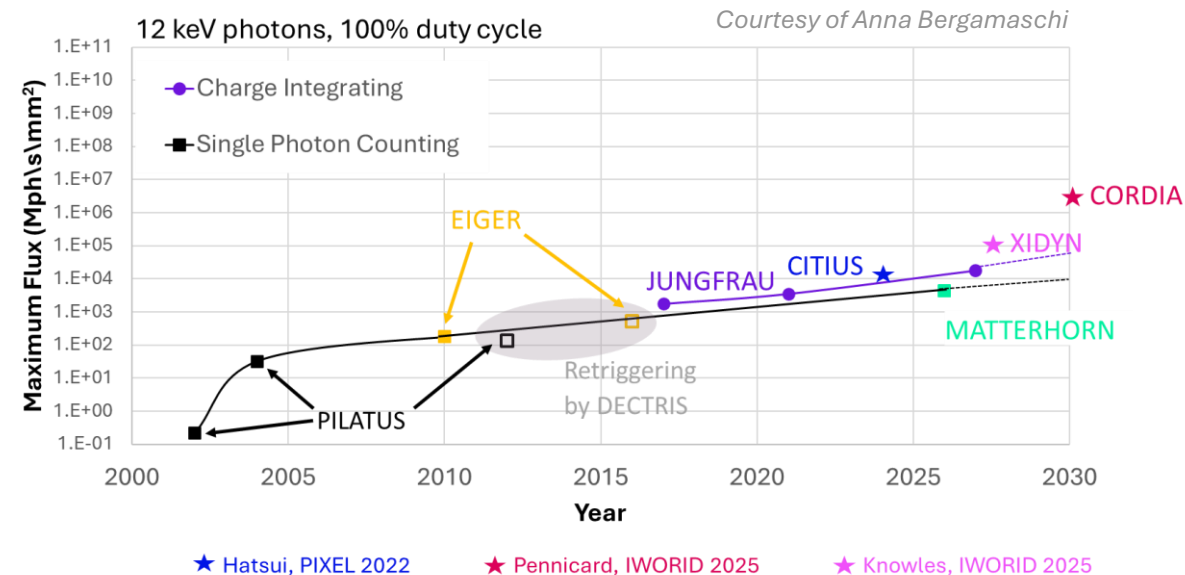

Science enabled by soft X-rays

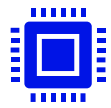

L-edges of many **important metals**

Mn, Fe, Cu ...



“**Water window**” and **light elements**

C and O K-edges (282 – 543 eV), Na, Mg, ...

- Resonant Inelastic X-ray scattering (RIXS)
- Coherent Diffraction Imaging

Commonly used commercial detectors for soft X-rays

- Readout speed ~ 1 Hz – 70 Hz
- Area ~ 2x2 – 4x4 cm²
- Limited dynamic range
- Radiation fragile

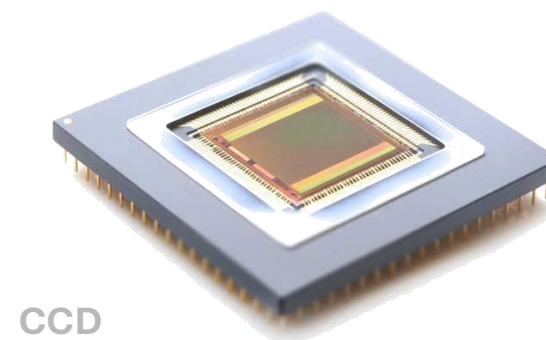
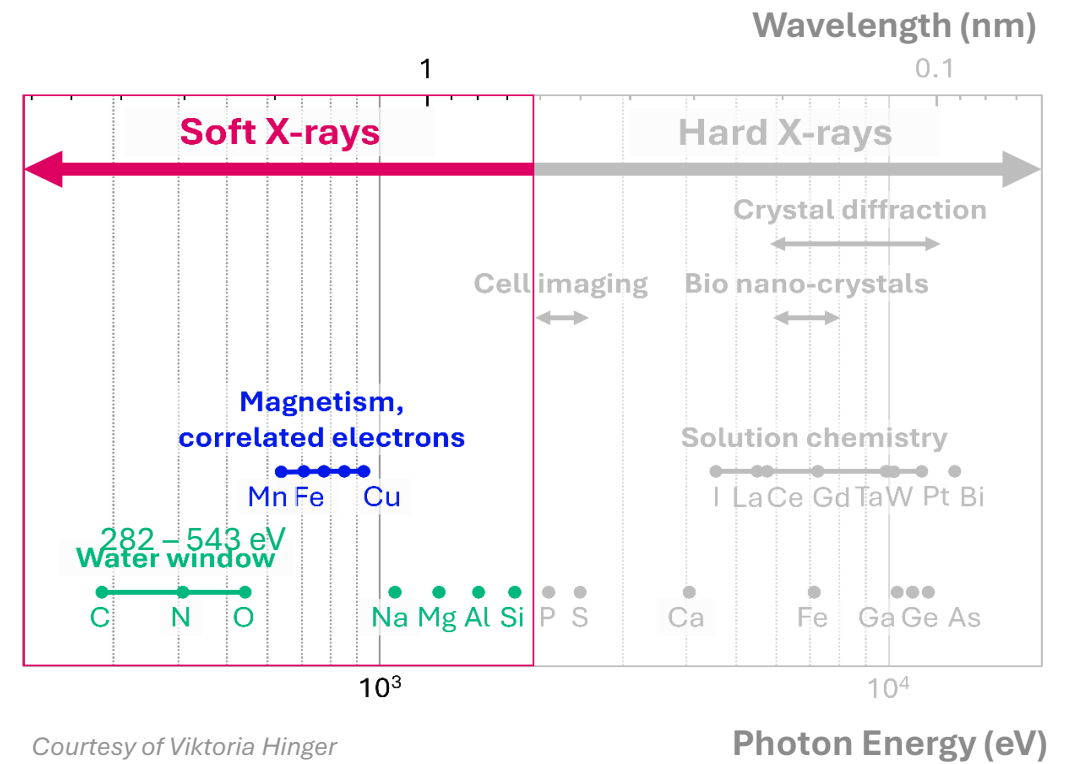

Low Quantum Efficiency (QE)

- Due to Shallow absorption depth of low-energy photons (100 nm @ 250 eV)
- Solution: **Thin Entrance Window (TEW)** technology

Poor Signal-to-Noise Ratio (SNR)

- Due to small charge created in the silicon sensor (70 e/h pair @ 250 eV)
- Solution: **Low Gain Avalanche Diode (LGAD)**

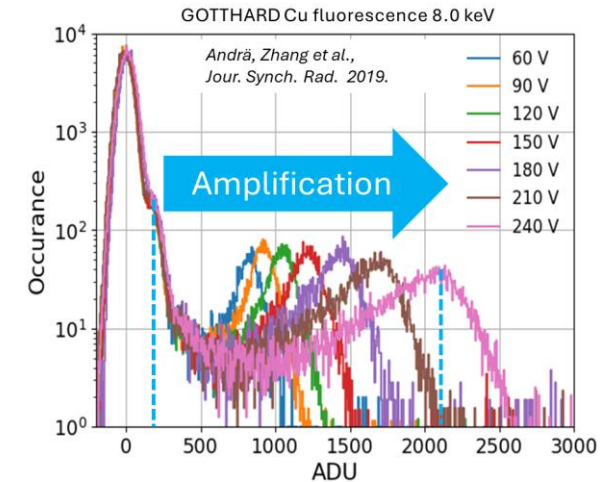
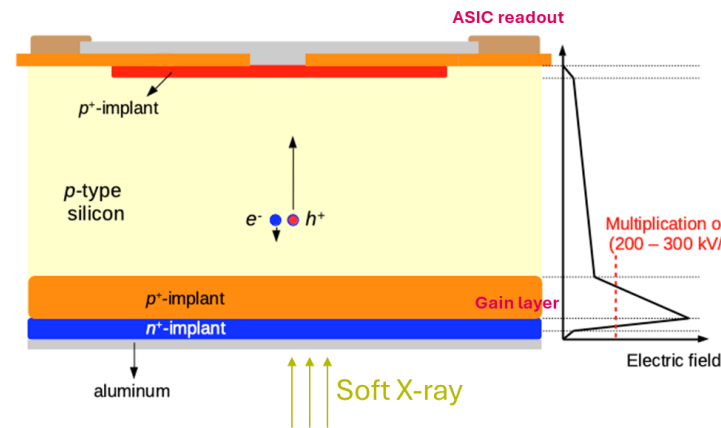
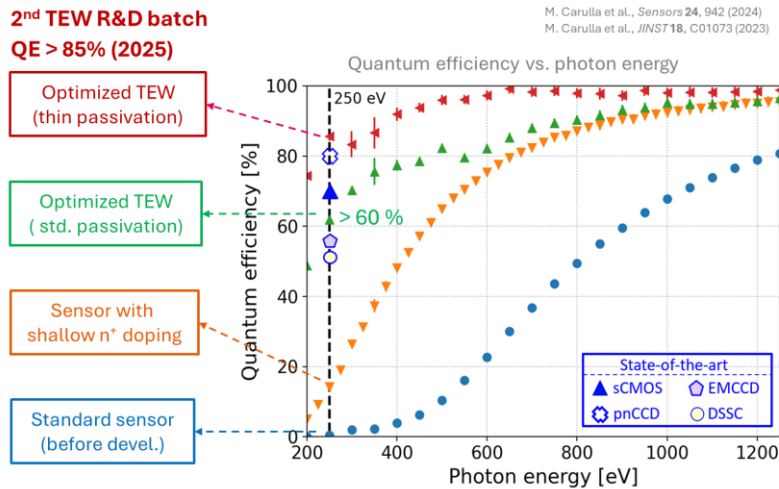

Single photon resolution down to ~400 eV

4 detector systems with LGAD planned for SLS2.0

MÖNCH: High Spatial and Energy Resolution for Photon-Starved Applications

	MÖNCH0.3	MÖNCH1.0
Pixel size	25x25 μm^2	
Chip size	160 kpixel 1x1 cm^2	≈ 1 Mpixel 2x2.5 cm^2
Module size		≈ 2 Mpixel 4x5 cm^2
Min Energy	~ 600 eV	~ 400 eV
Max Frame rate	6 kHz	0.5 kHz (ROI)

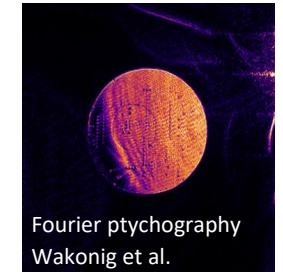
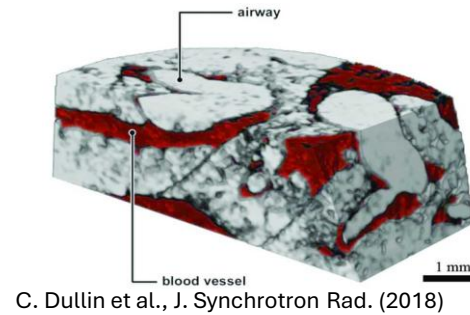

650 μm thick silicon

500 μm thick GaAs

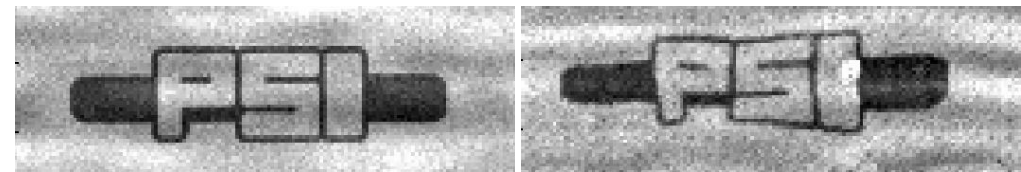
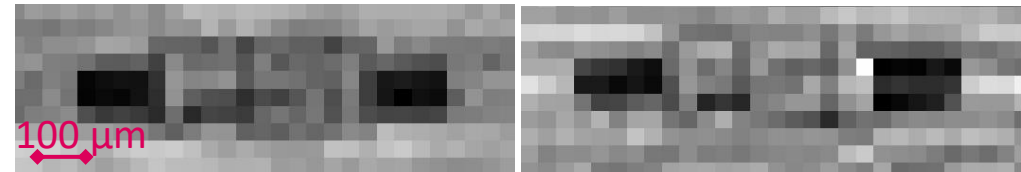

With fast frame rates and low fluxes

- Energy resolution \lesssim keV
- Super-resolution $\sim \mu\text{m}$

Developments to sustain higher fluxes

- Faster frame rates
- **Deep learning** to handle pile-up

LGAD sensor (unpublished)

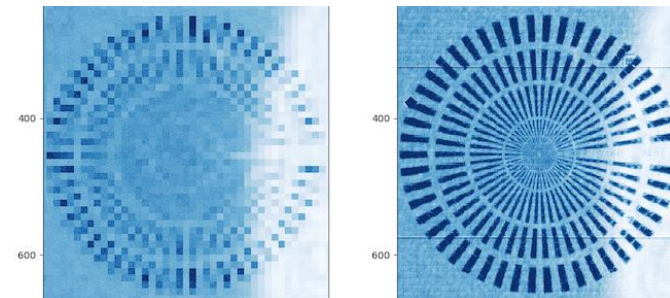

Super Resolution via Deep learning

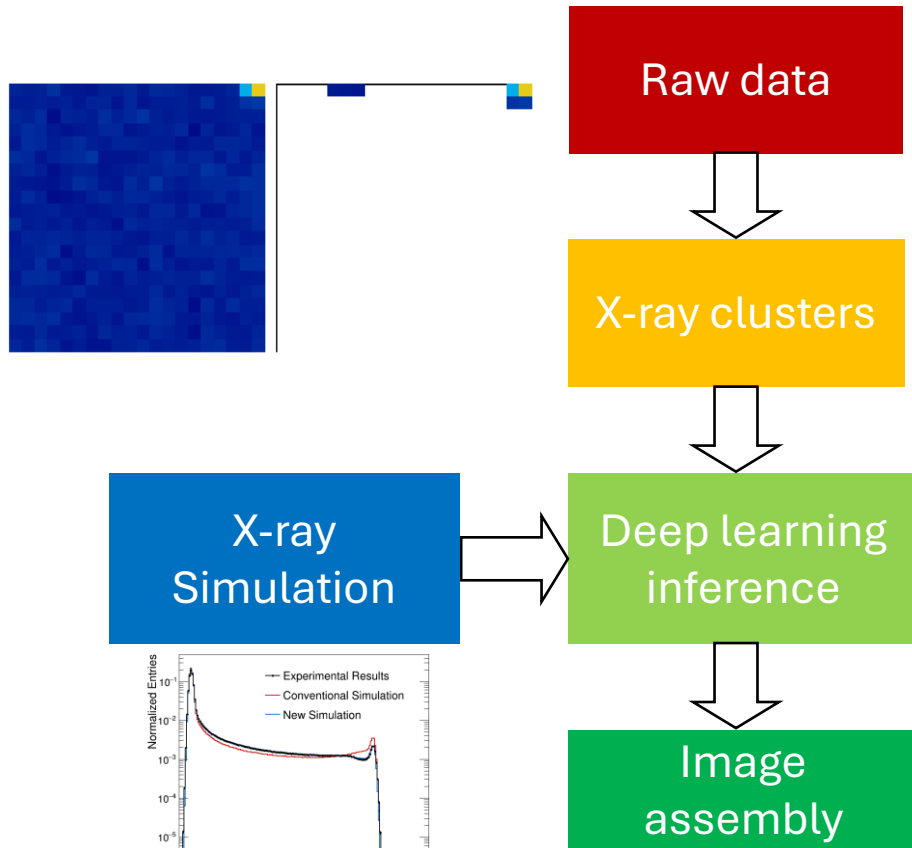

Xie, et al. NIMA 2026, 1081, 170894

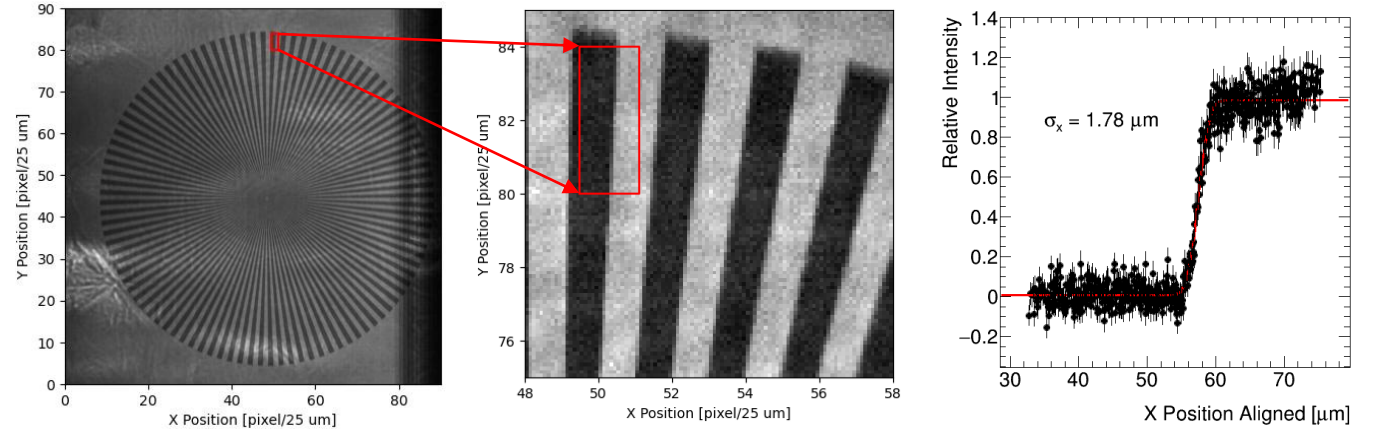

**Single photon localization: $\sigma_{DL} = 1.8 \mu\text{m}$ at 15 keV,
24% better than Eta interpolation**

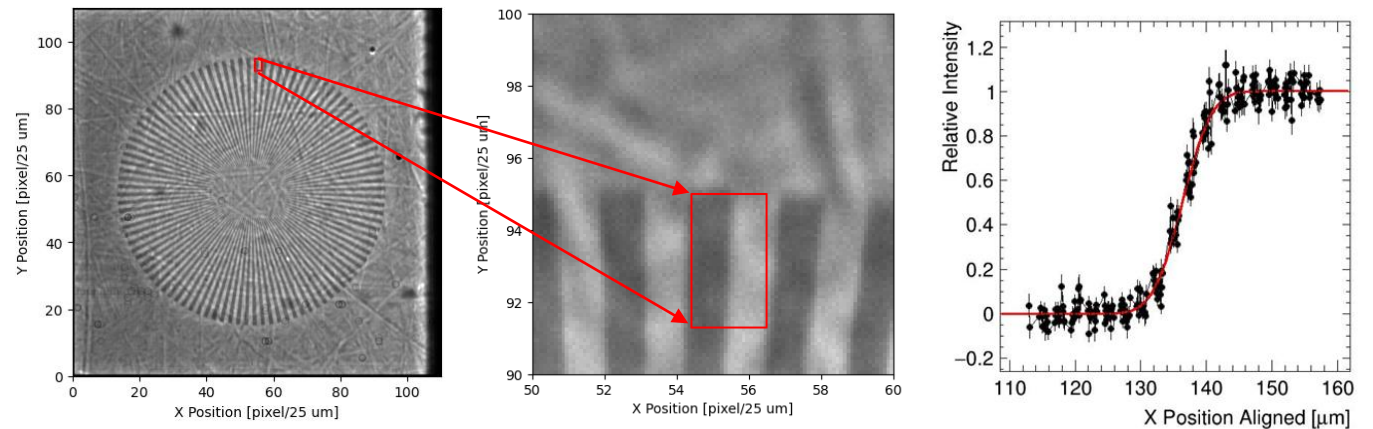

**Double photon localization: $\sigma_{DL} = 5.0 \mu\text{m}$ at 15 keV
Sub-pixel reconstruction becomes possible**

Thank you!



Back: V. Kedych, M. Müller, P. Sieberer, K. Ferjaoui, M. Brückner, E. Fröjdh, J. Heymes, C. Lopez-Cuenca.

Middle: K. Moustakas, C. Ruder, J. Mulvey, S. Silletta, V. Hinger, A. Mozzanica, M. Carulla, X. Xie,.

Front: R. Dinapoli, A. Bergamaschi, S. Li, D. Thattil, J. Zhang, A. Mazzoleni, V. Gautam, D. Mezza, T. King, B. Schmitt.

Missing: S. Ebner, D. Greiffenberg, S. Hasanaj, K.A. Paton, C. Posada, A. Haugdal.

Thank you!

