



*Introductory Part*

# *Collider Physics*

*Toni Baroncelli*  
*Haiping Peng*  
*USTC*

*Year 2024*



# Practicalities

These slides (and the Lecture Notes) will be made available at an Indico page being prepared

<http://cicpi.ustc.edu.cn/indico/categoryDisplay.py?categId=309>

Attending a course in English is difficult for young persons who are not too familiar with foreign languages

*I understand your difficulty and appreciate your effort  
The world of HEP (High Energy Physics) is a world-wide collaboration and English is the  
standard tool of communication. Attending these lectures will help you to improve your foreign  
language skills*

There are several ways to contact me:

1. By sending a mail to [toni.baroncelli@cern.ch](mailto:toni.baroncelli@cern.ch), please indicate “Student of Collider Physics” in the subject
2. Knock at my Office, 6<sup>th</sup> floor of the Modern Physics building (A606)

Do not hesitate to contact me for any question concerning the course

At the beginning of each new lecture I will give a short summary of the previous lecture with a list of main physics points

*Lecture notes will be prepared for (most) of the course*



# Overview of the Course

The Course will be shared between  
Haiping Peng and me, Toni Baroncelli

And is organized in several parts, lasting in total 16 weeks + 2 weeks for examinations:

(Tentative schedule)

Topic	Weeks	Who	from	→	# lectures
Introduction to basic concepts	2	T.Baroncelli	27/02/24	08/03/24	4
Deep Inelastic Scattering	1	T.Baroncelli	05/03/24	15/03/24	6
Accelerators	1	T.Baroncelli	12/03/24	22/03/24	8
Detectors	1	T.Baroncelli	19/03/24	29/03/24	10
Measurements at Colliders	3	T.Baroncelli	09/04/24	19/04/24	16
Standard Model Theory	2	H.Peng	24/04/24	03/05/24	4
CPV theory and experiment (BELLE, BABAR, LHCb)	2	H.Peng	08/05/24	17/05/24	8
Hadron physics (BESIII, STCF)	2	H.Peng	22/05/24	31/05/24	12
Higher Symmetries (GUT, SUSY, Superstrings....)	2	H.Peng	05/06/24	14/06/24	16



# Lecture Notes



Collider Physics

Haiping Peng  
Toni Baroncelli

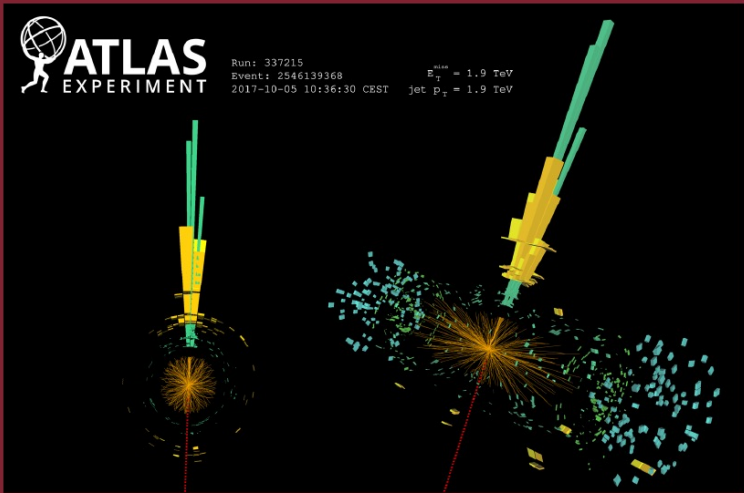

Lecture Notes for the 2022  
"Collider Physics"  
Course at USTC

I have prepared Lecture Notes for most of the course  
(.. Dynamic document, it will evolve with passing lectures).

Freely available



Collider Physics Course, Year 2021

- The points on the plot are seen to group in two families, corresponding to "Lepton Colliders" and "Hadron Colliders". Both families exhibit a similar growth as a function of time.
- "Lepton Colliders" (in practice today we only accelerate electrons and positrons), however, are significantly below the "Hadron Colliders" family. This is due to difficulties in the acceleration of electrons that limit the maximum centre of mass energy achievable.
- The linear trend observed in years 1960 to 2000 seems to curb due to technological limits both for hadron and lepton machines.
- The Livingston plot is also populated by 'future' accelerators indicating that, even though slower, the evolution of accelerators is expected to make available new generations of machines within a timescale of ~thirty years.
- All this indicates that it will be more and more difficult to access new accelerators and that once a new machine is built this will have to be exploited for decades.

8.

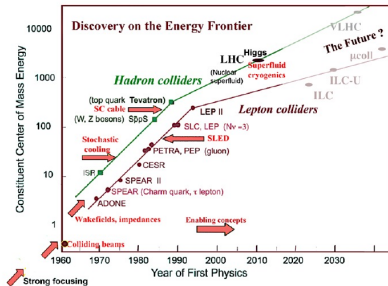

9. Figure 2-3: The Livingston plot.

As we have seen, in the last half a century, the physicists have been able to gain a factor 10 in  $\sqrt{s}$  by colliding two head-on beams. The complex technology that is at the base of these very accurate probes is perhaps at the limit of its reach. Also, the cost of these colliders is exploding at the level that no

Country alone in the world can sustain the cost of an accelerator of the future.

10. We all hope we will continue to have access to more and more powerful machines, but at some point, we will need a new technology breakthrough, since not many funds will be easily available in the foreseeable future.



Collider Physics Course, Year 2021

term  $E_M^2 (1 - \cos\theta)$  puts in correlation the scattering angle and the scattering energy of the electron. If we increase the target mass  $M$  the energy transfer  $E-E'$  increases as well.

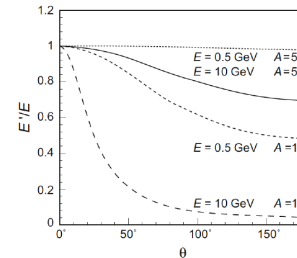

32. Figure 7-3: Ratio  $E'/E$  for two different values of the electron energy (0.5 and 10 GeV) and for two values of the atomic number

The correlation plot between  $\theta$  and the ratio  $E'/E$  is shown in the Figure 7-3 for two different values of the electron energy (0.5 and 10 GeV) and for two values of the atomic

number ( $A=1$ , hydrogen,  $A=50$ , tin). While for hydrogen the ratio  $E'/E$  is seen to vary very significantly, going from 0.6 to less than 0.1 at large angles, for high mass values the variation is much less important.

## 7.2. Rutherford scattering

First scattering experiments tried to give an answer to a basic (for the time) question: is the target of our scattering experiment a point-like object? What is the size of the scattering centres of our experiment? The approach followed by Rutherford was that of taking a source of alpha particles (easy, use a radio-active source) and collimated emitted alpha particles against a thin foil of Gold (Au). Later physicists realised that the results of the Rutherford experiment were interesting but could not be used beyond some level: using

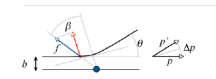

33. Figure 7-4: Kinematics of the  $e-p$  scattering

electrons (a real point-like projectile) was much better and the results could be used to study structures much smaller than with complex and massive alpha particles.

The kinematics of the scattering process is sketched in Figure 7-4. The projectile travels at a transverse distance  $b$  (see Figure 7-5)



Collider Physics Course, Year 2021: Deep inelastic scattering

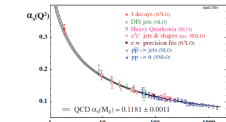

62. Figure 9-9: Evolution of  $\alpha_s$  as a function of  $Q^2$

## 10.3. Measuring (= Counting) the number of colours<sup>7</sup>

When the concept of colour was introduced above, we said that there are three colours, red, green and blue. This is not an information that comes down from the sky, it descends from an experimental observation that is described below.

This experimental observation is based on

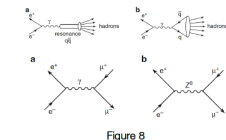

Figure 8

the study the production of

- $q\bar{q}$  pairs and of
- $\mu^+\mu^-$  pairs

in  $e^+e^-$  interactions where only virtual photons can be exchanged during the interaction between electrons and positrons.

The production of  $q\bar{q}$  pairs is shown in top part of figure 8. In the bottom part the Feynman diagrams for a  $\mu^+\mu^-$  pairs creation is shown (mostly mediated by photons, the exchange of the Z boson contributing very little).

In both final states,  $q\bar{q}$  pairs and  $\mu^+\mu^-$  pairs, the cross section depends on  $\alpha_s^2$ . Let us write the formula for the cross section in both cases:

$$\sigma(e^+e^- \rightarrow \mu^+\mu^-) = \frac{4\pi\alpha_{em}^2\hbar^2}{3s}$$

In this expression the charge squared of the muon,  $q_\mu^2$ , has been omitted since it is equal to 1. Things are different in the hadronic final state, which is the superposition of many different states,

$$\sigma(e^+e^- \rightarrow \gamma \rightarrow q\bar{q}) = N_c \frac{4\pi\alpha_{em}^2\hbar^2}{3s} \sum_{n=1}^N q_n^2$$

For both the final states the structure is the same but in the hadronic many more possible final states are open: this number is just given by  $N_c \sum_{n=1}^N q_n^2$  where  $N_c$  is the number

<sup>7</sup> Section 9.2 of [3]



# Forward: (Particle) Physics?

Experimental Science! Observation of *different* variables 1...n+3

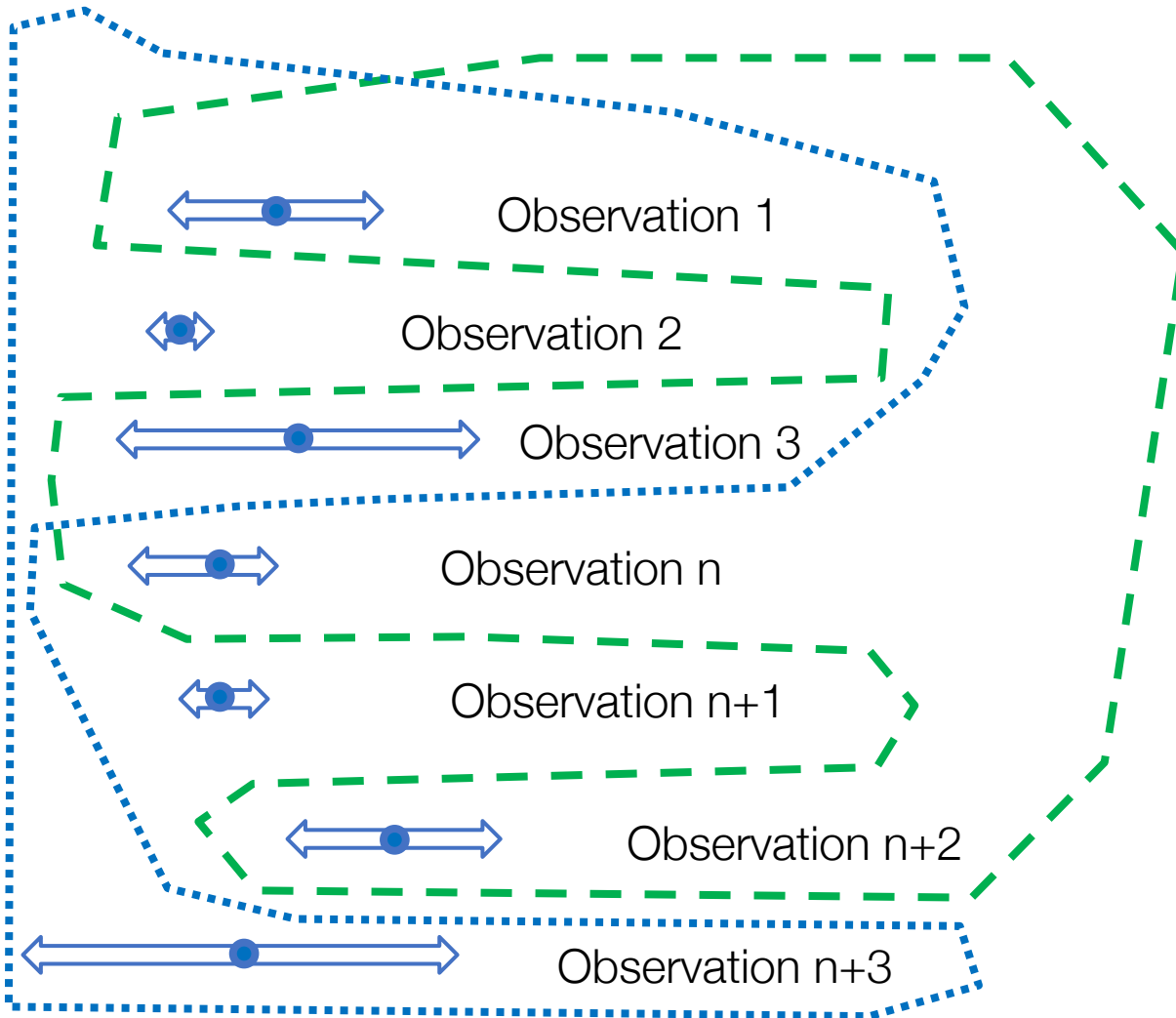

*Theory: establishes relations among observables (experiments)*

- All observables are accounted for in the theory → numerical predictions;
- Errors in the measurement;
- Infinite theories may describe the same set of observables;
- Two different theories are different IF they predict different observables or different outcomes of the same observables;
- → consistency of the theory
- → accuracy in the prediction;
- A theory can be falsified because of wrong predictions (... better say 'incompatible with observables');
- A theory cannot be qualified (proven) because a newer experiment can always disprove an older theory → THEORIES EVOLVE !



# Forward: why 'Collider Physics'?

We will see that to access the intimate structure of matter we have to use probes with wave-lengths as small as possible → high energy!

1. Accelerate particles onto targets (used in the past) or
2. Collide two beams against each other

The second option became accessible only with ~modern technologies.

Unprecedented high energies are reached → many discoveries

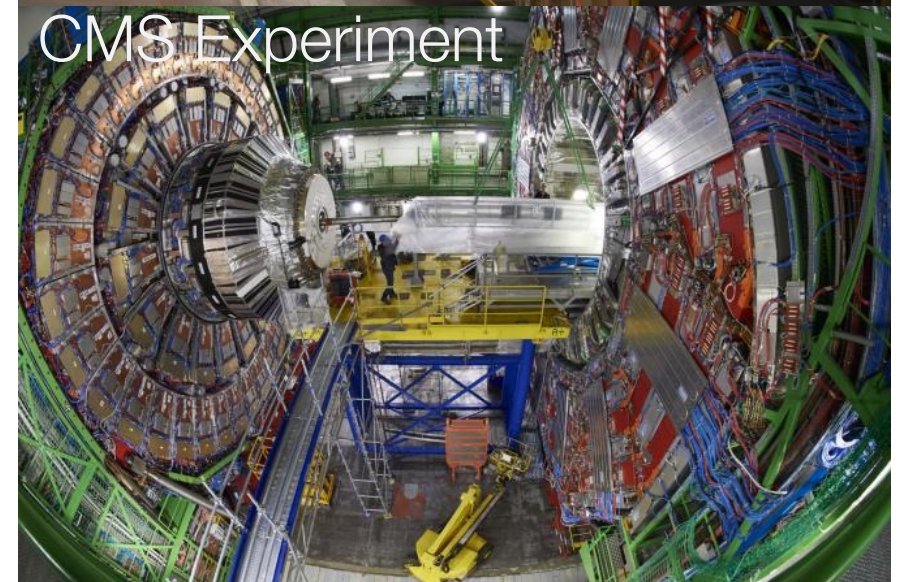
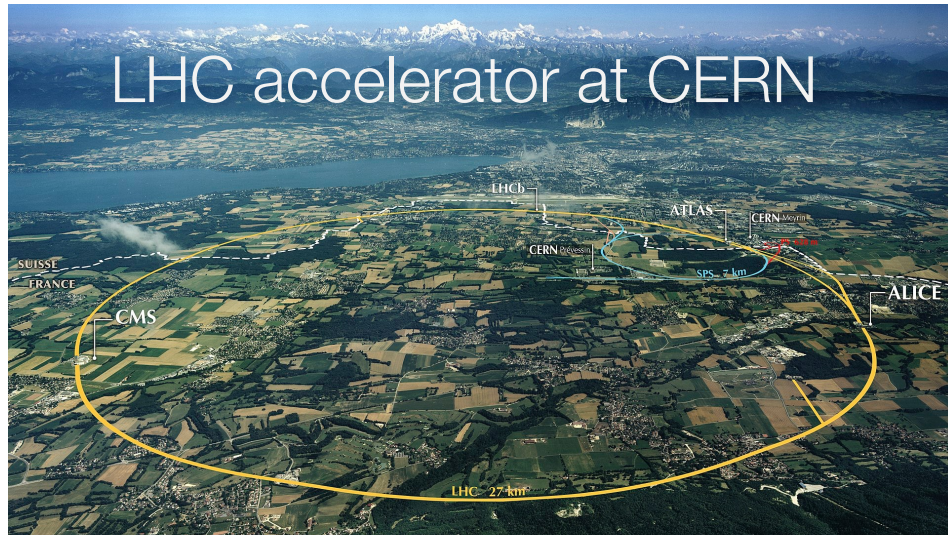



# Part One - Structure

## Topics

1. Probing the Structure of Matter
  2. Constituents of Matter & Quantum Numbers
  3. The Standard Model, Interactions and Vector Bosons
  4. Symmetries and Conservation Laws
  5. The Electro-Magnetic Case
  6. Feynman diagrams
  7. Cross Sections & the Golden Rule
  8. Electron – Nucleus Scattering
  9. Rutherford Scattering
  10. Form Factors
- The way we see things today,  
no historical approach → SM
- Basic Ingredients
- First Experiments



# Prologue: Many Order of Magnitude

(Reduced) Planck's Constant ( $\hbar = h/2\pi$ )  $h$

The uncertainty principle:  
 "position  $x$  (with uncertainty  $\Delta x$ ) and momentum  $p_x$  (with uncertainty  $\Delta p_x$ ) cannot simultaneously be known to better than

$$\Delta x \Delta p_x \sim \hbar/2.$$

A relation for the energy is obtained by multiplying  $c$ ,

$$\Delta x \Delta E \sim \frac{\hbar c}{2}$$

which gives numerically,

$$\Delta E (MeV) = \frac{1.973^{-11} (MeV \text{ cm})}{2 \Delta x (cm)}$$

Also  $\Delta x = c \Delta t \rightarrow \Delta t \Delta E \sim \frac{\hbar}{2}$

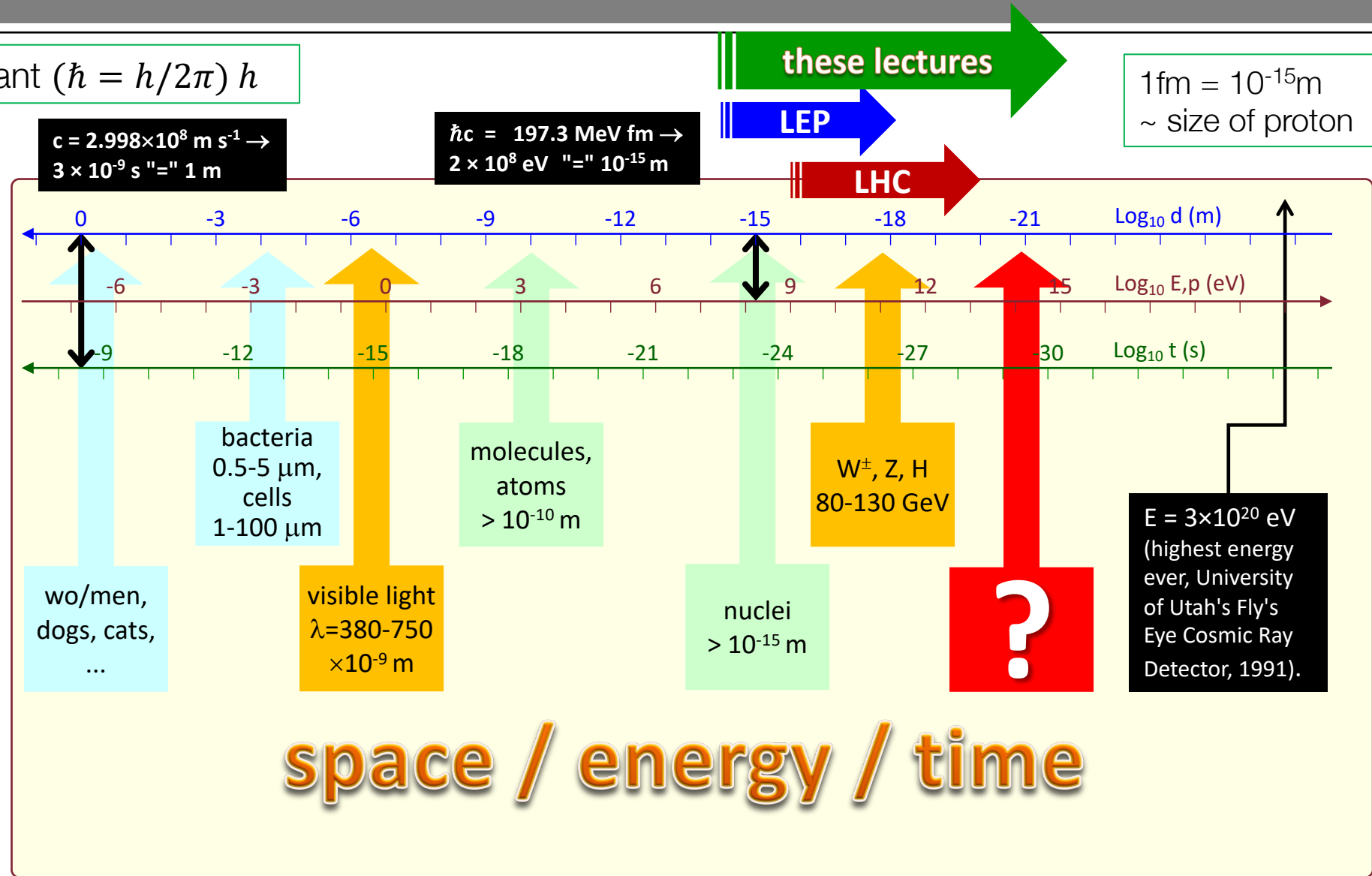





# *Prologue: the Quest for High Energy*

- Discovery range is limited by available data, i.e. by resources (like a microscope).
- The true variable is the resolving power of our microscope.

Quantum Mechanics, wave-particle duality:

- a particle has wave-like properties. A wave is characterized by its wavelength;
- a wave has particle-like properties.; a particle is characterized by its energy or its momentum.

The larger the particle energy, the smaller the associated wavelength.



# Prologue: the Quest for High Energy

- Resolving Power  $\propto$  Energy transferred in interaction,  $1/\sqrt{Q^2}$  [i.e.  $\propto 1/\sqrt{s}$ , the CM energy]
- For *non point-like objects*, replace  $\sqrt{s}$  with the CM energy at component level,  $\sqrt{\hat{s}}$  ( $\sqrt{\hat{s}} < \sqrt{s}$ ) (quarks in a proton, will see later).

$\Delta x$ (cm)	$E$	Tool
$10^{-5}$	2 eV	Microscopes
$10^{-8}$	2 keV	X rays
$10^{-11}$	2 MeV $\simeq 4m_e$	$\gamma$ rays
$10^{-14}$	2 GeV $\simeq 2m_p$	Accelerators
$10^{-16}$	200 GeV $\simeq 2m_{W,Z}$	Accelerators
$10^{-17}$	2 TeV	Accelerators

## LHC, as an example

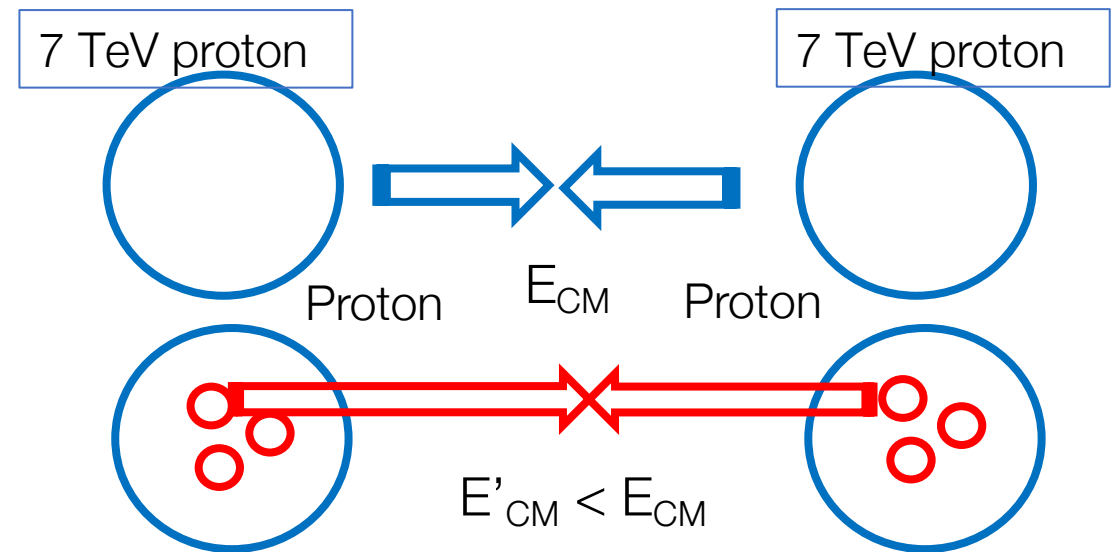

The CM energy at component level is lower! Quarks carry a fraction of the proton energy



# Prologue: the Quest for High Energy

- In the last half a century, the physicists have been able to gain a factor 10 in  $\sqrt{s}$  every 10 years (see the "Livingston plot").
  - Fixed target (1 beam on a thin target)
  - Two head-on beams (more complex technology)
- **No Country** in the world can sustain the cost of an accelerator of the future
- Hope it will continue like that, but needs IDEAS, since not many \$\$\$ (or €€€) will be available.

CEPC in China(\*)?

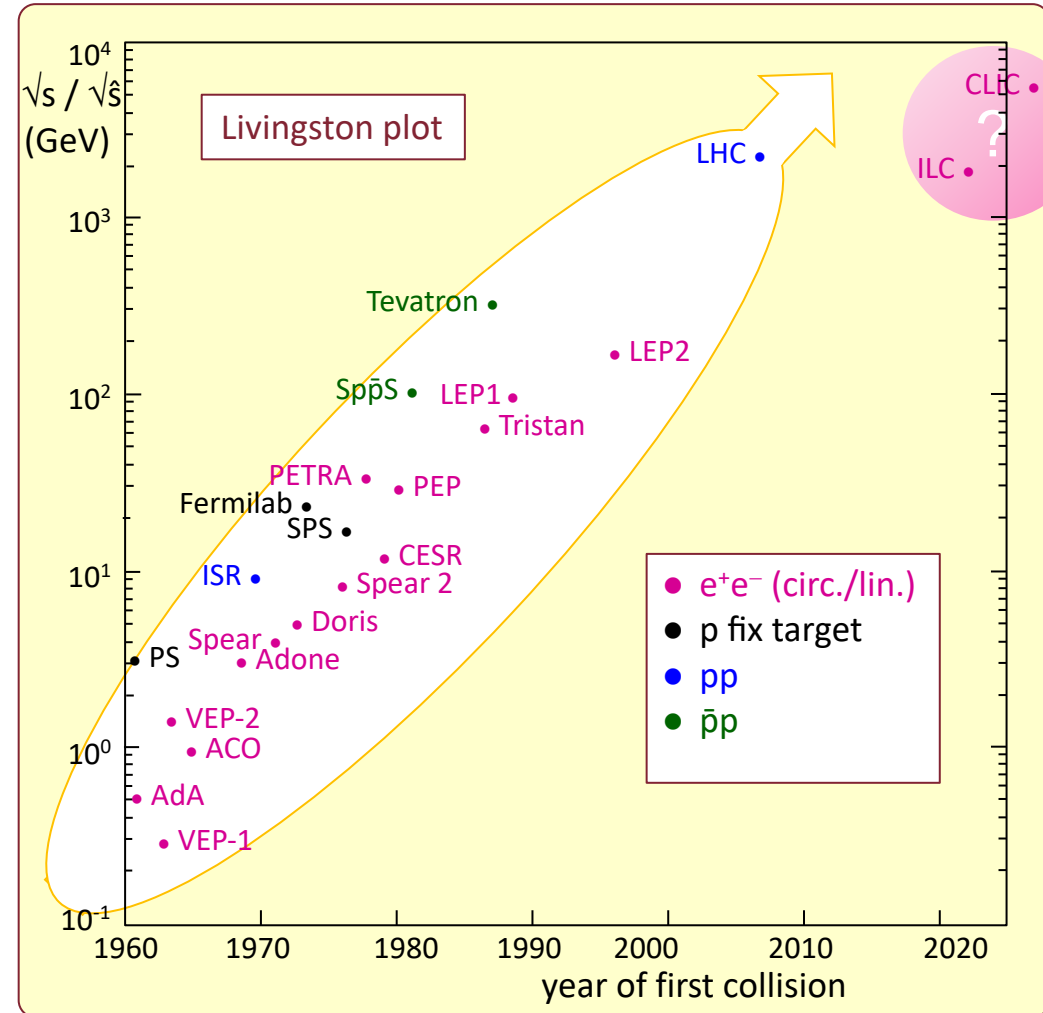

(\*) <http://cepc.ihep.ac.cn/intro.html>



# The Livingston Plot

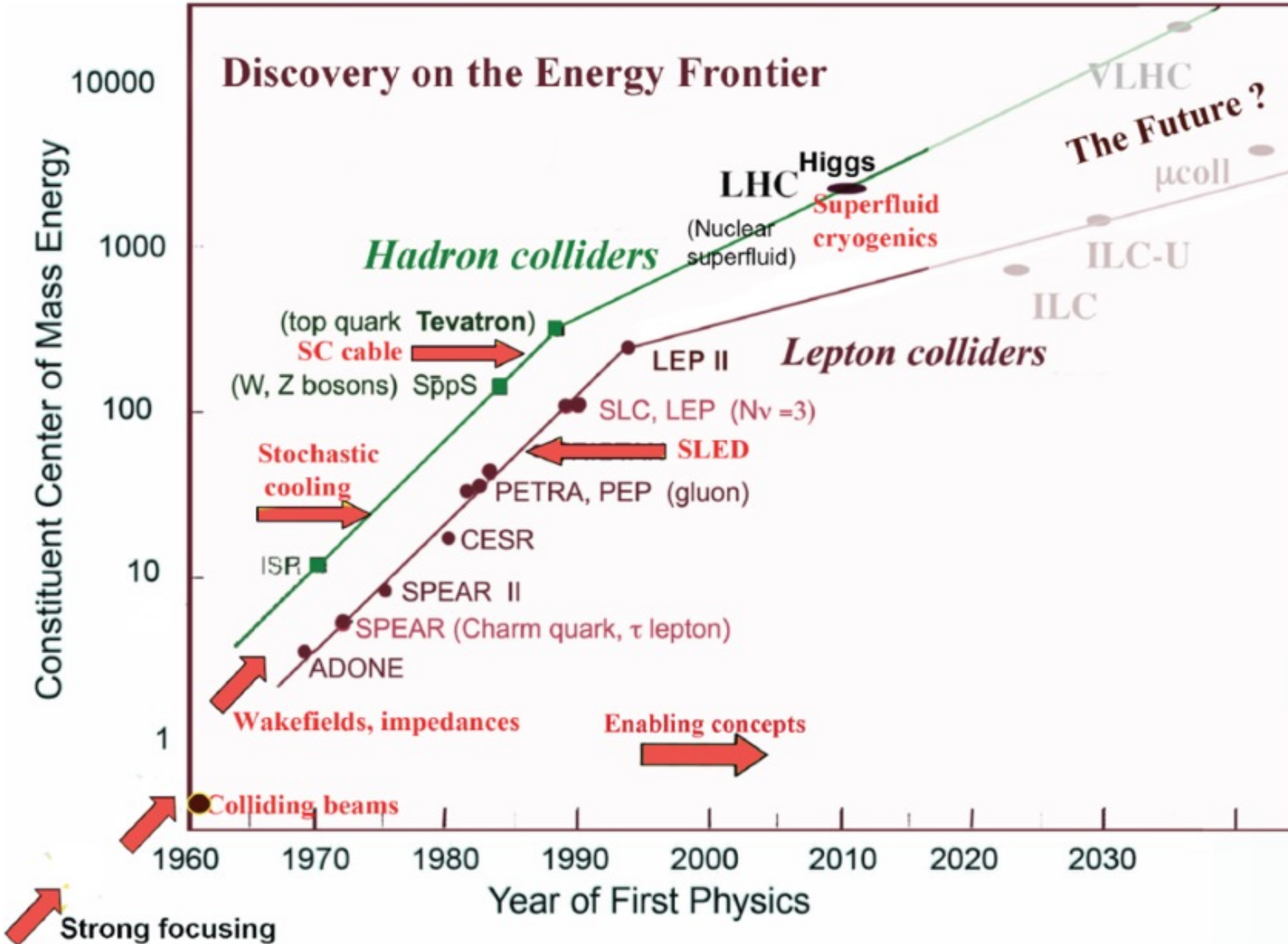



# Prologue: The Standard Model

- SM designates the theory of the Electromagnetic, Weak and Strong interactions. The theory has grown in time, the name went together.
- The development of the SM is an interplay between new ideas and measurements.

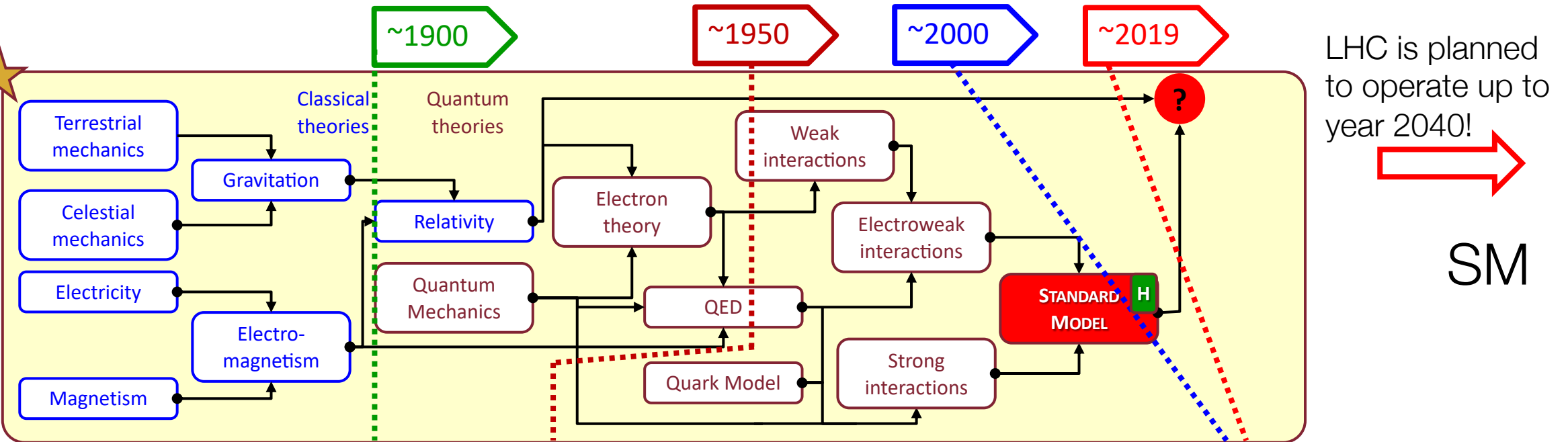

- Many theoreticians contributed : since the G-S-W (S.Glashow, A.Salam,S.Weinberg) model is at the core of the SM, it is common to quote them as the main authors.



# Theory and Experiments

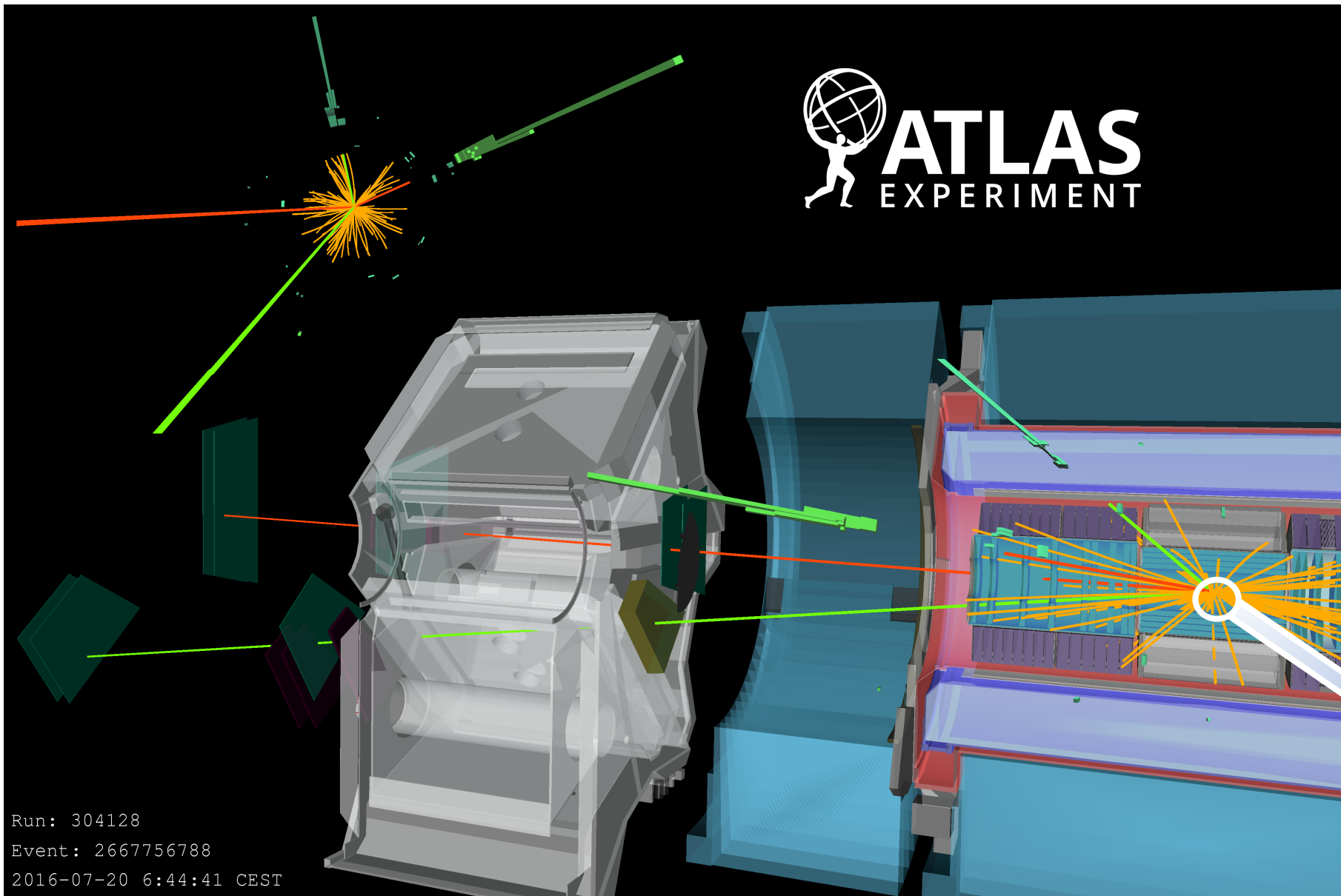

Experiments: instruments and devices that allow you to 'see' the result of an interaction described by Theory.

'see' is a proxy for 'visualise'!

Theory! You do not see what is (happens) inside.



# Reminder (mostly) of Quantum Mechanics

*Look at Lecture Notes!*

- Contravariant four vectors (index up)  $x^\mu = (t, x, y, z)$
- Covariant four vectors (index down)  $x_\mu = (t, -x, -y, -z)$
- $x^\mu x_\mu = x^0 x_0 + x^1 x_1 + x^2 x_2 + x^3 x_3$

QM = Quantum Mechanics  
 $\hbar$  = Planck Constant

- all the information regarding a physical system is contained in the corresponding wavefunction
- Free particles (we use natural units  $\hbar, c = 1$ ) can be expressed as

$$\psi(\mathbf{x}, t) = N \cdot e^{i(\mathbf{p} \cdot \mathbf{x} - Et)}$$

- Operators acting on a wavefunction return an observable (real number)  $\hat{A}\psi = a\psi$
- Hamiltonian:  $E = H = T + V$

Natural Units

Quantity	kg, m, s	$\hbar, c, \text{GeV}$	$\hbar = c = 1$
Energy	$\text{kg m}^2 \text{s}^{-2}$	GeV	GeV
Momentum	$\text{kg m s}^{-1}$	GeV/c	GeV
Mass	kg	$\text{GeV}/c^2$	GeV
Time	s	$(\text{GeV}/\hbar)^{-1}$	$\text{GeV}^{-1}$
Length	m	$(\text{GeV}/\hbar c)^{-1}$	$\text{GeV}^{-1}$
Area	$\text{m}^2$	$(\text{GeV}/\hbar c)^{-2}$	$\text{GeV}^{-2}$

- If an Hamiltonian leaves unchanged an observable then  $[\hat{H}, \hat{O}] = \hat{H}\hat{O} - \hat{O}\hat{H} = 0$
- $\hat{p} = -i\nabla$  and  $\hat{E} = i\frac{\partial}{\partial t}$
- $\hat{p}$  returns  $\mathbf{p}$ ,  $\hat{E}$  returns E



# Non-relativistic Schrödinger equation

$$E = H = T + V = \frac{\mathbf{p}^2}{2m} + V \sim \text{Valid at low energy}$$

$\hat{p} = -i\nabla$  and  $\hat{E} = i\frac{\partial}{\partial t}$  applied to  $\psi(\mathbf{x}, t) = N \cdot e^{i(\mathbf{p}\cdot\mathbf{x} - Et)}$  gives

$$\rightarrow \hat{H}\psi(\mathbf{x}, t) = \frac{1}{2m} (-i\nabla)^2 \psi(\mathbf{x}, t) + \hat{V}\psi(\mathbf{x}, t)$$

$$i \frac{\partial \psi(\mathbf{x}, t)}{\partial t} = -\frac{1}{2m} \frac{\partial^2 \psi(\mathbf{x}, t)}{\partial x^2} + \hat{V}\psi(\mathbf{x}, t)$$

Two 'weak' points:

- it contains 2<sup>nd</sup> order derivatives in space and 1<sup>st</sup> order in time → it is not relativistic invariant → inadequate to describe high energy phenomena (low energy approximation)
- Has some other theoretical weakness





# The Klein-Gordon Equation

The *Schrödinger* equation is not relativistic invariant → go to the Einstein relation between energy and momentum:

$$E = \frac{\mathbf{p}^2}{2m} \rightarrow E^2 = \mathbf{p}^2 + m^2$$

(Note that you go from  $E$  to  $E^2$  )

The  $E^2$  and  $\mathbf{p}^2$  terms of this equation are interpreted as operators that act on a wavefunction (as before  $\hat{p} = -i\nabla$  and  $\hat{E} = i \frac{\partial}{\partial t}$ ):

$$\hat{E}^2 \psi(x) = \hat{\mathbf{p}}^2 \psi(x) + m^2 \psi(x)$$
$$(\partial^\mu \partial_\mu + m^2) \psi(x, t) = 0$$

Where

$$\partial^\mu \partial_\mu = \frac{\partial^2}{\partial t^2} - \frac{\partial^2}{\partial x^2} - \frac{\partial^2}{\partial y^2} - \frac{\partial^2}{\partial z^2}$$

It gives an unphysical negative energy solution !

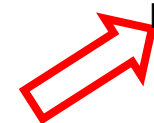

Problem is that the solution gives  $E = \pm \sqrt{p^2 + m^2}$   
(and other theoretical difficulties)

*Alternative solution needed*



# The Dirac Equation

Dirac tried a different approach and wrote an equation with first order derivatives only

$$\hat{E}\psi(\mathbf{x}, t) = (\boldsymbol{\alpha} \cdot \hat{\mathbf{p}} + \beta \cdot m) \cdot \psi(\mathbf{x}, t)$$

Attention!! Terms  $\alpha$  and  $\beta$  are NOT necessarily numbers!

If we write this explicitly (using the usual replacement  $\hat{\mathbf{p}} = -i\nabla$  and  $\hat{E} = i\frac{\partial}{\partial t}$ ) we get

$$i\frac{\partial}{\partial t}\psi = \left(-i\alpha_x\frac{\partial}{\partial x} - i\alpha_y\frac{\partial}{\partial y} - i\alpha_z\frac{\partial}{\partial z} + \beta m\right)\psi$$

$$E^2 = \mathbf{p}^2 + m^2$$

The solutions of the Dirac equation have to be a solution of the Klein-Gordon equation. → Constraints on the  $\alpha$  and  $\beta$  terms.

$$\begin{aligned} \alpha_x^2 &= \alpha_y^2 = \alpha_z^2 = I \\ \alpha_j\beta + \beta\alpha_j &= 0 \\ \alpha_j\alpha_k + \alpha_k\alpha_j &= 0 \quad (j \neq k) \end{aligned}$$

Where I represents unity. →  $\alpha$  and  $\beta$  are matrices. It can be shown that  $\alpha$  and  $\beta$  matrices, have even dimensions, the minimum value being 4x4

- have trace 0
- have eigenvalues  $\pm 1$
- are Hermitian

the solution for the Dirac equation has to be a four-component (*Dirac-spinor*) wavefunction:

$$\psi = \begin{pmatrix} \psi_1 \\ \psi_2 \\ \psi_3 \\ \psi_4 \end{pmatrix}$$



# Physical Interpretation – Association to Spin

It is natural to think of spinors as associated to spin

$$u_1(E, \mathbf{p}) = N \begin{pmatrix} 1 \\ 0 \\ \frac{p_z}{E+m} \\ \frac{p_x+ip_y}{E+m} \end{pmatrix} \text{ and } u_2(E, \mathbf{p}) = N \begin{pmatrix} 0 \\ 1 \\ \frac{p_x-ip_y}{E+m} \\ \frac{-p_z}{E+m} \end{pmatrix}$$

Positive energy solution,  $u_1$  and  $u_2$  wave functions with positive energy and spin up and spin down respectively

$$u_3(E, \mathbf{p}) = N \begin{pmatrix} \frac{p_z}{E-m} \\ \frac{p_x+ip_y}{E-m} \\ 1 \\ 0 \end{pmatrix} \text{ and } u_4(E, \mathbf{p}) = N \begin{pmatrix} \frac{p_x-ip_y}{E-m} \\ \frac{-p_z}{E-m} \\ 0 \\ 1 \end{pmatrix}$$

Negative energy solution,  $u_3$  and  $u_4$  wave functions with *negative* energy and spin up and spin down respectively

These solutions satisfy both the Einstein relation  $E^2 = p^2 + m^2$  and the Dirac equation.

- The first two solutions have  $E = \sqrt{p^2 + m^2}$  while
- the other two solutions have  $E = -\sqrt{p^2 + m^2}$ .

Again negative energy solutions !!

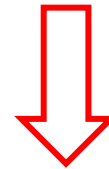



# Physical Interpretation – Negative Energies?

The existence of negative energy solutions is a problem.

Dirac tried to solve it by saying that all negative energy states are ‘occupied’ and there is no room to accept ‘positive states’. → Historical interest only

Later *Stückelberg* and *Feynman* proposed a different interpretation:

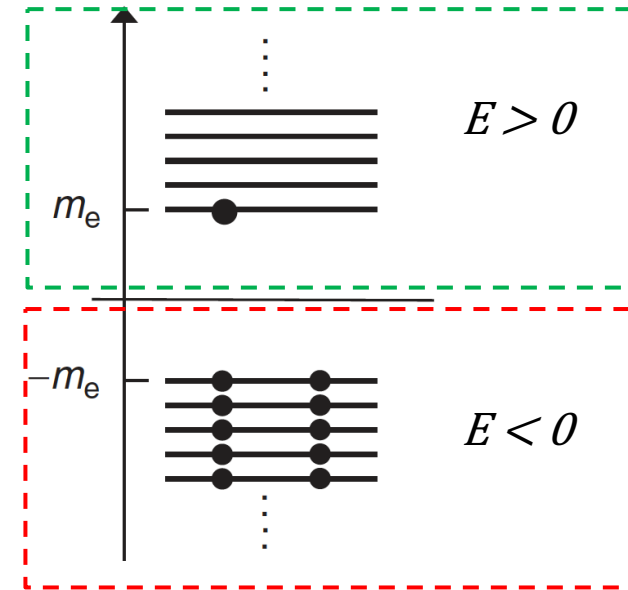

The time dependence of the solutions to the Dirac equation is

$$e^{-iEt}$$

term. If you change

$$t \rightarrow -t \text{ and } E \rightarrow -E$$

the time behaviour is unaffected.

**Solution** → existence of an antiparticle with positive energy, opposite charge to that of the corresponding particle and propagating forward in time.

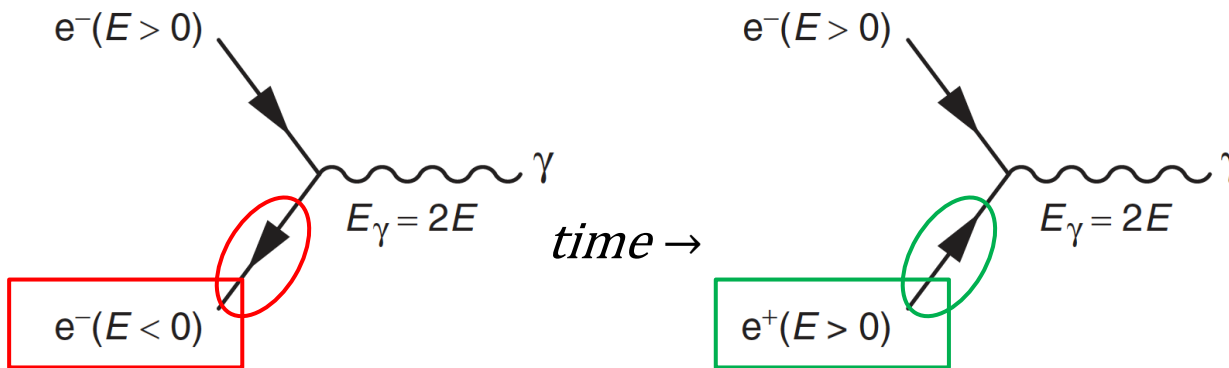

This interpretation was later validated by many experimental observations.



# Dirac equation, spin & negative energy values

Let us elaborate a bit more:

$$\psi(\mathbf{x}, t) = u(E, \mathbf{p})e^{i(\mathbf{p}\cdot\mathbf{x}-Et)}$$

For a particle at rest

$$\psi(\mathbf{x}, t) = u(E, \mathbf{0})e^{-iEt}$$

$$E \begin{pmatrix} 1 & 0 & 0 & 0 \\ 0 & 1 & 0 & 0 \\ 0 & 0 & -1 & 0 \\ 0 & 0 & 0 & -1 \end{pmatrix} \begin{pmatrix} \phi_1 \\ \phi_2 \\ \phi_3 \\ \phi_4 \end{pmatrix} = m \begin{pmatrix} \phi_1 \\ \phi_2 \\ \phi_3 \\ \phi_4 \end{pmatrix}$$

With 4 solutions:

Positive energy solutions

$$u_1(E, 0) = N \begin{pmatrix} 1 \\ 0 \\ 0 \\ 0 \end{pmatrix}, u_2(E, 0) = N \begin{pmatrix} 0 \\ 1 \\ 0 \\ 0 \end{pmatrix}$$

Negative energy solutions

$$u_3(E, 0) = N \begin{pmatrix} 0 \\ 0 \\ 1 \\ 0 \end{pmatrix}, u_4(E, 0) = N \begin{pmatrix} 0 \\ 0 \\ 0 \\ 1 \end{pmatrix}$$



# Explicit solutions to the Dirac equation

$$\psi_1 = N \begin{pmatrix} 1 \\ 0 \\ 0 \end{pmatrix} e^{-imt}, \quad \psi_2 = N \begin{pmatrix} 0 \\ 1 \\ 0 \end{pmatrix} e^{-imt}, \quad \psi_3 = N \begin{pmatrix} 0 \\ 0 \\ 1 \end{pmatrix} e^{+imt} \quad \text{and} \quad \psi_4 = N \begin{pmatrix} 0 \\ 0 \\ 0 \end{pmatrix} e^{+imt}.$$

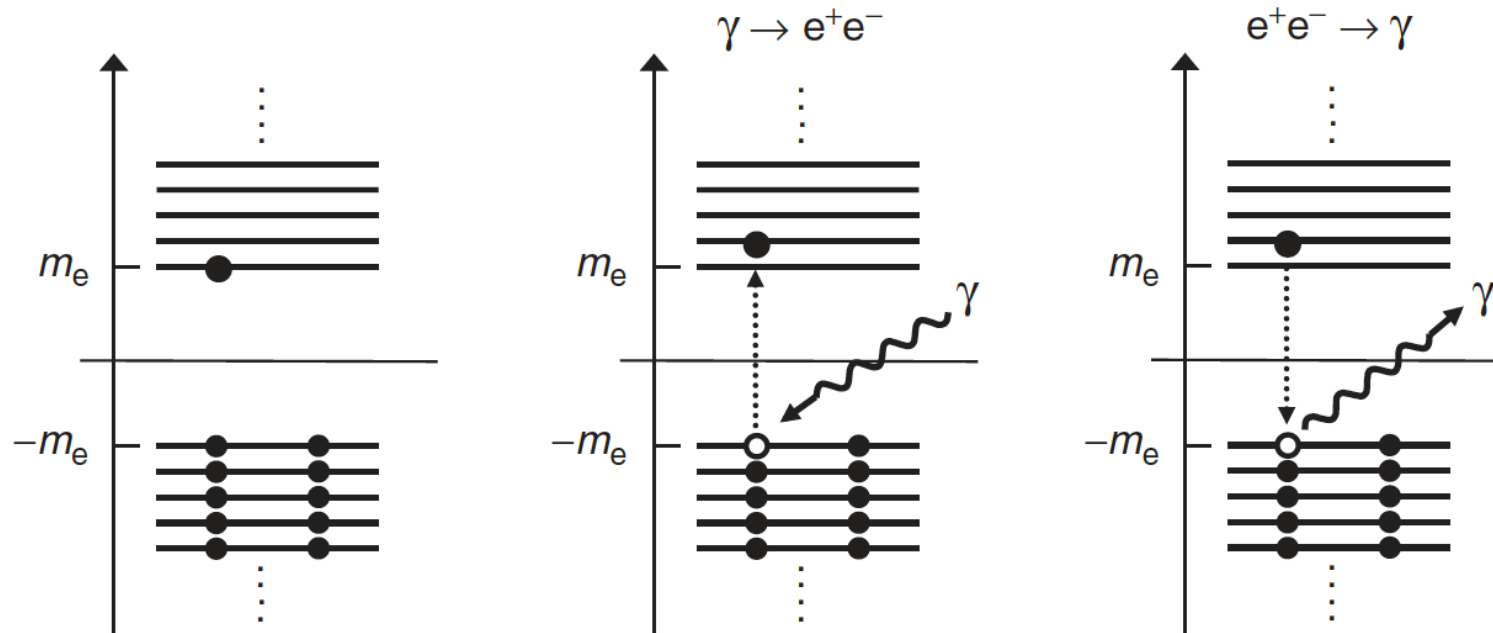

Existence of the physical state of an antiparticle with positive energy, opposite charge to that of the corresponding particle and propagating forward in time

Two explanations:

- Dirac: negative energy states are all occupied, the Pauli principles makes impossible to fill one such state with two identical particles;
- Feynman observed that : the time dependence is contained in the  $e^{-iEt}$  term. If you change  $t \rightarrow -t$  and  $E \rightarrow -E$  the time behaviour is left unaffected;
- When one 'negative energy' state is excited (by a photon)  $\rightarrow$  leaves a 'hole' state with less negative energy and a positive charge with respect to the fully occupied  $-E$  states.



# Spin and Helicity

At this point we may introduce two antiparticle spinors  $v_1(E, \mathbf{p})$  and  $v_2(E, \mathbf{p})$  where, simply,  
the sign of  $E$  and  $\mathbf{p}$  have been reversed:

$$v_1(E, \mathbf{p})e^{-i(\mathbf{p}\cdot\mathbf{x}-Et)} = u_4(-E, -\mathbf{p})e^{-i(-\mathbf{p}\cdot\mathbf{x}-(-E)t)}$$

$$v_2(E, \mathbf{p})e^{-i(\mathbf{p}\cdot\mathbf{x}-Et)} = u_3(-E, -\mathbf{p})e^{-i(-\mathbf{p}\cdot\mathbf{x}-(-E)t)}$$

If we choose  $p_z \neq 0, p_{x,y} = 0,$  (as an example!) the spinors for particles and anti particles become

$$u_1(E, \mathbf{p}) = N \begin{pmatrix} 1 \\ 0 \\ \frac{p_z}{E+m} \\ 0 \end{pmatrix} \text{ and } u_2(E, \mathbf{p}) = N \begin{pmatrix} 0 \\ 1 \\ 0 \\ \frac{-p_z}{E+m} \end{pmatrix}$$

$$v_1(E, \mathbf{p}) = N \begin{pmatrix} \frac{p_z}{E-m} \\ 0 \\ 1 \\ 0 \end{pmatrix} \text{ and } v_2(E, \mathbf{p}) = N \begin{pmatrix} 0 \\ \frac{-p_z}{E-m} \\ 0 \\ 1 \end{pmatrix}$$

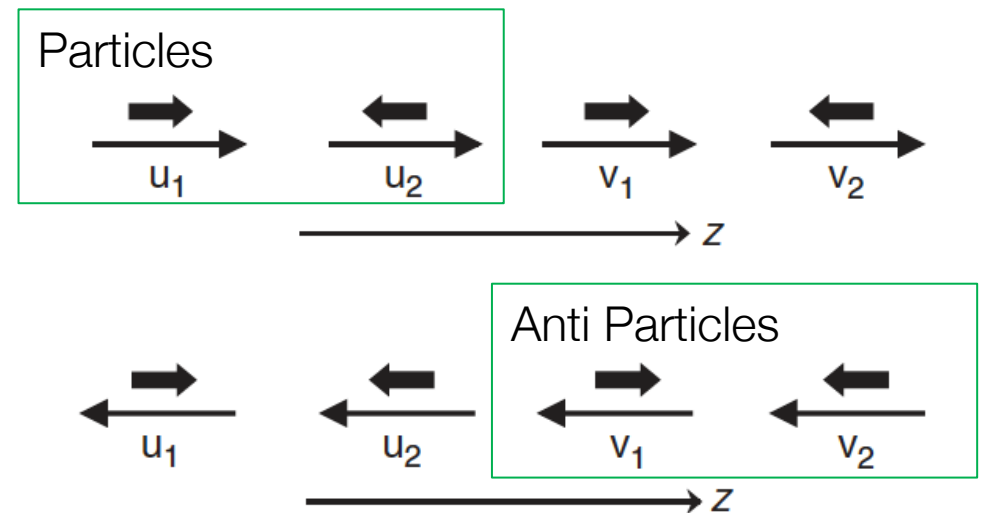



# Spin and Helicity

If we define a spin-operator and we apply it to the spinors just introduced we get

$$\hat{S}_z = 1/2 \begin{pmatrix} \sigma_z & 0 \\ 0 & \sigma_z \end{pmatrix} = \begin{pmatrix} 1 & 0 & 0 & 0 \\ 0 & -1 & 0 & 0 \\ 0 & 0 & 1 & 0 \\ 0 & 0 & 0 & -1 \end{pmatrix}$$

$$\begin{aligned} \hat{S}_z u_1(E, 0.0, \pm p) &= +1/2 u_1(E, 0.0, \pm p) \\ \hat{S}_z u_2(E, 0.0, \pm p) &= -1/2 u_2(E, 0.0, \pm p) \\ \hat{S}_z v_1(E, 0.0, \pm p) &= +1/2 v_1(E, 0.0, \pm p) \\ \hat{S}_z v_2(E, 0.0, \pm p) &= -1/2 v_2(E, 0.0, \pm p) \end{aligned}$$

A generalisation has to be introduced by defining the concept of helicity  $h$ :

$$h = \frac{\mathbf{S} \cdot \mathbf{p}}{p}$$

*The helicity  $h$  is the component of the spin along the direction of motion. The corresponding operator  $\hat{h}$  is now defined as (see the 'Matrix section' in the Lecture Notes)*

$$\hat{h} = 1/2 \begin{pmatrix} \sigma \cdot \hat{p} & 0 \\ 0 & \sigma \cdot \hat{p} \end{pmatrix}$$

- The helicity commutes with the free-particle Hamiltonian  $\rightarrow$  the spinors are both eigenstates of the helicity operator and of the free particle Hamiltonian.
- The corresponding eigenvalues are  $\pm 1/2$ .
- Particles with helicity  $+1/2$  are righthanded, particles with helicity  $-1/2$  are lefthanded.





# The Standard Model

*The Standard Model (SM) is the best description we have today of the microscopic world*

- Describes accurately known phenomena
- Important predictive power
- Incorporates known particles, forces and the interaction among them
- Predicted the existence of the Higgs Boson (discovered in 2012).

However the SM is not really a theory, it is rather a 'Model':

- Many parameters(\*) have to be fixed 'by-hand' to describe data
- *SM* created an infrastructure with locations for particles and forces but is not able to explain why it is like that

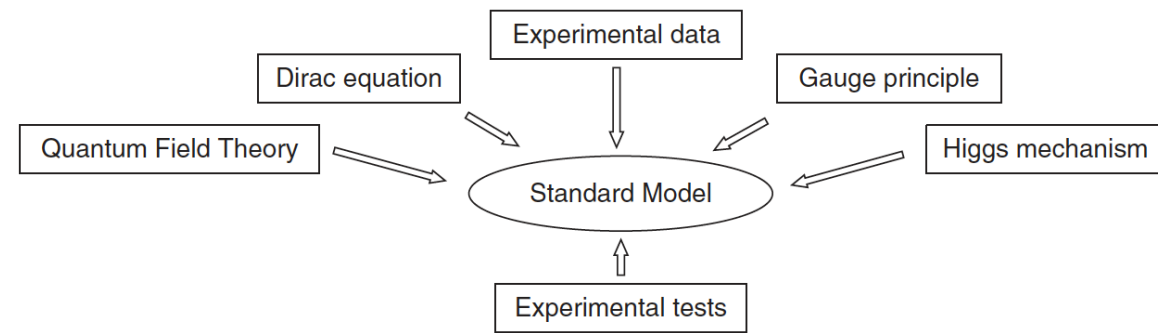

The *SM* is not the end of the story!  
More has to exist and needs to be discovered.

→ *BSM* is called the '*Beyond Standard Model*' Physics. It will incorporate the *SM* and its capacity to describe / predict microscopic phenomena

(\*) SM parameters: masses of twelve fermions, three strengths of gauge interactions, two parameters for the Higgs potential, eight parameters of the mixing matrix CKM → 25 parameters



# Constituents of Matter (a 'picture of the World')

**Table 1** : Fundamental fermions and bosons in the standard model of the microcosm

## Fermions

$\begin{pmatrix} u \\ d \end{pmatrix}$	$\begin{pmatrix} c \\ s \end{pmatrix}$	$\begin{pmatrix} t \\ b \end{pmatrix}$	Quarks
$\begin{pmatrix} \nu_e \\ e^- \end{pmatrix}$	$\begin{pmatrix} \nu_\mu \\ \mu^- \end{pmatrix}$	$\begin{pmatrix} \nu_\tau \\ \tau^- \end{pmatrix}$	Leptons

First family    Second family    Third family

Leptons and quarks considered to be the *ultimate* fermionic constituents of matter. Quarks (and antiquarks) appear in three different colours (and anticolours)

## Bosons

Fundamental Interactions	Mediators
--------------------------	-----------

Strong	8 gluons
Electromagnetic	$\gamma$
Weak	$W^+, W^-, Z^0$

the force carriers of the fundamental interactions, the vector (*spin 1*) bosons, must be added

Gravitational	Graviton
---------------	----------

Higgs Boson	$H^0$
-------------	-------

scalar (*spin 0*) Higgs boson. The Higgs boson has been observed; it is thought to be the main ingredient in the mechanism that attributes mass to the particles.

The fact that there are so many particles and that so few constitute the present **stable matter** is not currently understood. It is also unclear why the ultimate fermionic constituents appear in **three families**, each constituted of two leptons and two quarks, and each being a replica of the same type, see Table 1



# Quantum Numbers of Quarks and Leptons

**Table 2** : Leptons and quarks (spin  $\frac{1}{2}$  fermions) of the first family

For each particle we have an *anti-particle*: it has the opposite quantum numbers of the *particle* and opposite charge but same mass and spin

First family				
	Symbol	$Q$	$L_e$	$B$
Leptons	$\nu_e$	0	1	—
	$e^-$	-1	1	—
Quarks	$u$	+2/3	—	+1/3
	$d$	-1/3	—	+1/3

$Q$  is the electric charge in unit of the proton charge,  $L_e$  is the electronic lepton number,  $B$  the baryonic number.

Stable particles are:

- photon
- neutrinos and the antineutrinos
- the electron, the positron
- proton and the antiproton  $p$

All others are unstable.

- The first family includes the quarks  $u, d$  and the leptons  $e, \nu_e$ .
- The ordinary matter is constituted of quarks  $u, d$  and of electrons  $e$ .
- The second and third families seem to be "replicas" of the first one. Leptons and quarks of generations higher than first can be produced at accelerators



# The Standard Model (2)

Force Carrier	Photon	W & Z Boson	Gluons	Graviton
	EM	Weak	Strong	Gravitational
Quarks	✓	✓	✓	✓
Leptons	✓	✓		✓
Neutrinos		✓		

the neutrinos, being uncharged, are only subject to the weak interaction

The *hadrons* are composed of quarks and are known in two topologies:

- those constituted by three quarks (the *baryons*, like the proton and neutron) and
- those constituted by a quark-antiquark pair (the *mesons*).
- As for leptons, antiquarks also exist and particles composed of three antiquarks are called *antibaryons*.

As will be discussed later, the number of baryons and leptons is conserved (one anti-particle counts with a “-” sign). This means that, as described by the relationship  $E = mc^2$ , the energy can be converted in mass in the form of particles; nevertheless,

the total number of baryons and leptons must be conserved.

→ If an electron is produced, it must be created in association with a positron (its antiparticle, with electric charge and leptonic number of opposite sign) as expected from the Dirac theory.



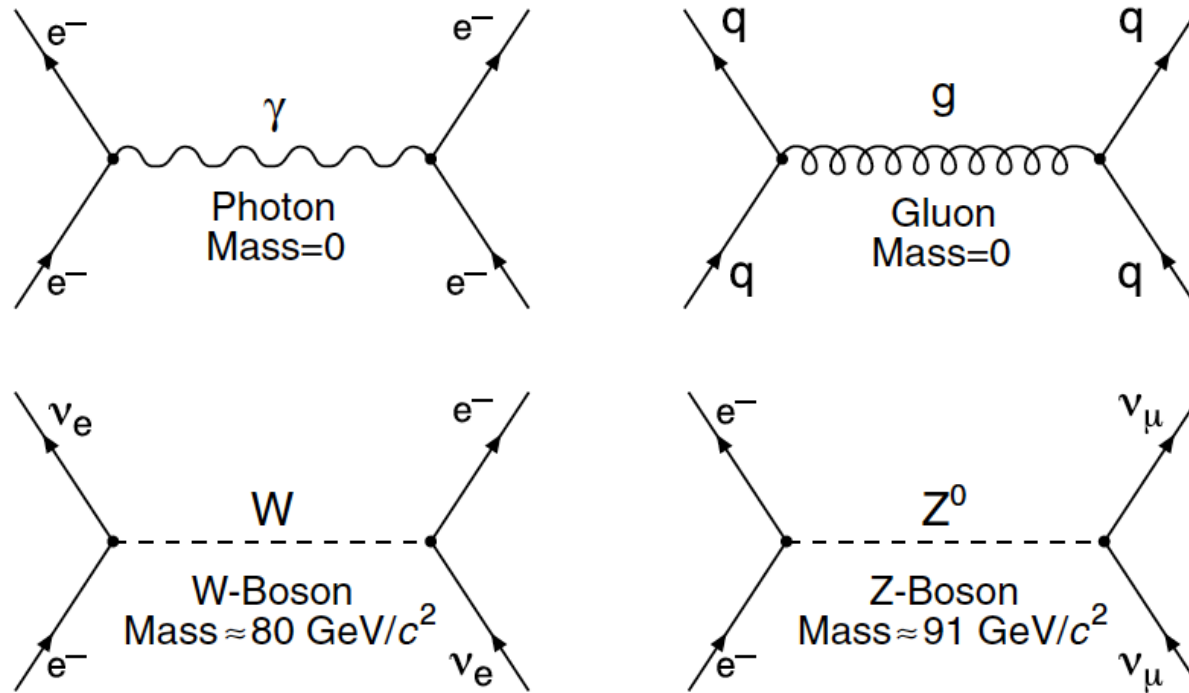

# Interactions and Vector Bosons



Interactions are mediated by the exchange of **vector bosons**, i.e. particles with spin 1: *photons*, *gluons*,  $W^+$ ,  $W^-$  and  $Z^0$  bosons. Gravity is mediated by a spin 2 boson, the *graviton*

Graphic representation of the different type of interactions between two particles are shown in the diagrams to the left.

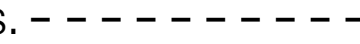
- leptons and quarks by straight lines, 
- photons by wavy lines, 
- gluons by spirals, and 
- $W^\pm$  and  $Z^0$  by dashed lines. 

Each of these three interactions is associated with a charge: electric charge, weak charge and strong charge. The strong charge is also called colour charge or colour for short.

***A particle is subject to an interaction if and only if it carries the corresponding charge:***

- Leptons and quarks carry weak charge.
- Quarks are electrically charged, so are some of the leptons (e. g., electrons).
- Colour charge is only carried by quarks (not by leptons).



# Interactions

<i>Vector Boson</i>	<i>Mass</i>	<i>Charge</i>	<i>Comment</i>
Photon	0	N	The rest mass of the photon is zero. Therefore, the range of the electromagnetic interaction is infinite. Photons, however, have no electrical charge → do not interact with each other
$W^\pm$	$\approx 80$ GeV/c <sup>2</sup>	Y	Heavy particles can only be produced as virtual, intermediate particles in scattering processes for extremely short times. Therefore, the weak interaction is of very short range
$Z^0$	$\approx 91$ GeV/c <sup>2</sup>	N	
Gluon	0	Y	The gluons, like the photons, have zero rest mass. Gluons, however, carry colour charge. Hence they can interact with each other. As we will see, this causes the strong interaction to be also very short ranged.



# Symmetries and Conservation Laws

*Symmetries are associated to conservation laws and conservation laws are associated to symmetries.*

Effect on a system  $\Psi$  of a 'transformation operator'  $\hat{U}$

$$\Psi \rightarrow \psi' = \hat{U}\psi$$

$$(\hat{H}\psi_j = E_j\psi)$$

If physical predictions do not change under  $\hat{U} \rightarrow$

- $\hat{U}\hat{U}^\dagger$  must be unitary (if you go & come back you get to the starting point)  $\rightarrow$  no change ;
- The operator  $\hat{U}$  commutes with the Hamiltonian:  $[\hat{H}, \hat{U}] = \hat{H}\hat{U} - \hat{U}\hat{H} = 0$

A continuous transformation (translation or rotation)  $\sim$  sequence of 'many' infinitesimal transformations

$$\hat{U}(\epsilon) = \hat{I} + i\epsilon\hat{G}$$

'Infinitesimal transformation  $\rightarrow$  transformation  $\epsilon$ , of 'type'  $\hat{G}$

If  $[\hat{H}, \hat{U}] \rightarrow [\hat{H}, \hat{G}] \rightarrow$  An operator acting on a system returns an observable  $\rightarrow$  The observable is conserved

(\*) or rather the invariance of the equations that describe how a system evolves under transformations



# Invariance & Symmetry

physical systems are described by an equation.  
The system is considered as invariant if the equation describing it is invariant under given transformation

*Important: Invariance properties → conservation laws.*

There are two types of transformations:

- *continuous* (like a translation or rotation, it can be seen as a series of infinitesimal transformations)
- *discrete* (like the transition from one state to another).

Symmetry	Conserved Quantity
Spatial Rotation	Angular Momentum
Temporal Translation	Energy
Spatial Translation	Momentum
EM gauge invariance	Electric charge

**Classical mechanics** a state with  $n$  degrees of freedom is characterised by  $n$   $q_i$  coordinates and  $n$  conjugate momenta  $p_i$ . The evolution of the system is described, in the Lagrangian formalism, by

$$\mathcal{L} = T - V = \text{kinetic energy} - \text{potential energy}$$

$$p_i = \frac{\partial \mathcal{L}}{\partial \dot{q}_i}$$

$$\frac{dp_i}{dt} - \frac{\partial \mathcal{L}}{\partial q_i} = 0$$

*Noether's theorem:*  
A conserved quantity is associated to a continuous symmetry

If  $\mathcal{L}$  does not depend on  $q_i$  then  $\frac{dp_i}{dt} = 0 \rightarrow$  the conjugated momentum  $p_i$  is constant





# Continuous Transformations

$$\frac{dp_i}{dt} - \frac{\partial \mathcal{L}}{\partial q_i} = 0$$

## • Translation along $x$

- Let us consider the system Lagrangian  $\mathcal{L} = T - V = \frac{1}{2} m \dot{x}^2$ . In this case,  $\mathcal{L}$  does not depend on  $x$  and is invariant under translations along the  $x$  axis  $\rightarrow p_x = \frac{\partial \mathcal{L}}{\partial \dot{x}} = m\dot{x} = \text{constant}$  i.e., the momentum  $p_x = m\dot{x}$  is conserved.
- In Lecture Notes the translation  $x \rightarrow x + \epsilon$  inducing  $\Psi(x) \rightarrow \psi'(x) = \psi(x + \epsilon)$  in the Hamiltonian representation is also examined to show the same result

## • Rotations

- The Lagrangian  $\mathcal{L} = T - V = \frac{1}{2} m \dot{\phi}^2 r^2$  where  $\dot{\phi} r = v$  does not depend on  $\phi$ ; this implies that  $\mathcal{L}$  is invariant under spatial rotations  $p_\phi = \frac{\partial \mathcal{L}}{\partial \dot{\phi}} = m\dot{\phi} r^2 = mvr$  is constant, i.e., that the angular momentum is conserved.



# Discrete Transformations

Three discrete symmetries are very important in particle physics:

- **spatial parity (P)**:  $\psi(\mathbf{r}, t) \rightarrow \psi(-\mathbf{r}, t)$
- **charge conjugation (C)**:  $p \rightarrow \bar{p}$
- **time reversal (T)**:  $\psi(\mathbf{r}, t) \rightarrow \psi(\mathbf{r}, -t)$

Constraints on possible reactions



Also important

- CP
- CPT

↓

Symmetry Properties based on Observations

Symmetry	Spatial Parity (P)	(C) Charge Conjugation	(T) Time Reversal	(CP)	(CPT)
Strong Interactions	Conserved	Conserved	Conserved	Conserved	Conserved
Elec.magn. Interactions	Conserved	Conserved	Conserved	Conserved	Conserved
Weak Interactions	Not conserved	Not conserved	Conserved	Not always violated	Conserved

*All are good symmetries of both the electromagnetic and strong interactions.*

- The weak interaction breaks both C and P symmetries maximally but is CP-invariant for many processes. Violation of CP invariance has been observed in the interactions of neutral meson systems, particularly kaons and beauty mesons.
- The product of all three, CPT, is **expected** to be a universal symmetry of physics and is an important assumption of quantum field theory.



# Parity of Fermions & Bosons

Bosons and antibosons have integer spin (follow the Bose-Einstein statistics) & the same intrinsic parity. Fermions and antifermions have half integer spin and opposite parities.

It is assumed that

- *Bosons*:  $\psi(1,2) = \psi(2,1)$  *symmetric*
- *Fermions*:  $\psi(1,2) = -\psi(2,1)$  *anti-symmetric*

$$\begin{aligned}
 &P(\text{quarks/leptons}) = \\
 +1 &= P_{e^-} = P_{\mu^-} = P_{\tau^-} = P_u = P_d = P_s = \dots; \\
 -1 &= P_{e^+} = P_{\mu^+} = P_{\tau^+} = P_{\bar{u}} = P_{\bar{d}} = P_{\bar{s}} = \dots
 \end{aligned}$$

The total wave function of **two** particles is the product of two terms

**Spatial function** x **Spin function**

Motion of 1 particle with respect to the other ~ described by spherical harmonics  $Y_l^m(\vartheta, \varphi)$

Dirac theory → Spin function is symmetric if the two spins are parallel ↑↑ and anti-symmetric if they are opposite ↑↓

Bosons : both Spatial and Spin functions are symmetric or anti-symmetric

Fermions : one function is symmetric while the other one is anti-symmetric

- $\Psi(x) = \cos(x)$  has positive parity [ $\cos(x) = \cos(-x)$ ]
- $\Psi(x) = \sin(x)$  has negative parity [ $\sin(x) = -\sin(-x)$ ]
- $\Psi(x) = \cos(x) + \sin(x)$  parity is not defined



# Symmetries in Particle Physics: Parity

**Parity (P)** reflection symmetry: depending on whether the sign of the wave function changes under reflection or not, the system is said to have negative or positive **P** respectively. For those laws of nature with left-right symmetry, the parity quantum number **P** of the system is conserved.

Parity refers to a transformation that inverts spatial coordinates, like a reflection:

$$x, y, z \rightarrow -x, -y, -z \quad r \rightarrow -r \quad \text{Exchange right} \leftrightarrow \text{left} \quad [\Theta \rightarrow \pi - \Theta \text{ and } \phi \rightarrow \phi + \pi]$$

$$P\psi(\mathbf{r}) = \psi(-\mathbf{r})$$

If applied twice gives back the original wave function

$$P^2\psi(\mathbf{r}) = PP\psi(\mathbf{r}) = P\psi(-\mathbf{r}) = \psi(\mathbf{r})$$

This implies that eigenvalues of **P** are  $\pm 1$ .

- $\Psi(x) = \cos(x)$  has positive parity [ $\cos(x) = \cos(-x)$ ]
- $\Psi(x) = \sin(x)$  has negative parity [ $\sin(x) = -\sin(-x)$ ]
- $\Psi(x) = \cos(x) + \sin(x)$  parity is not defined

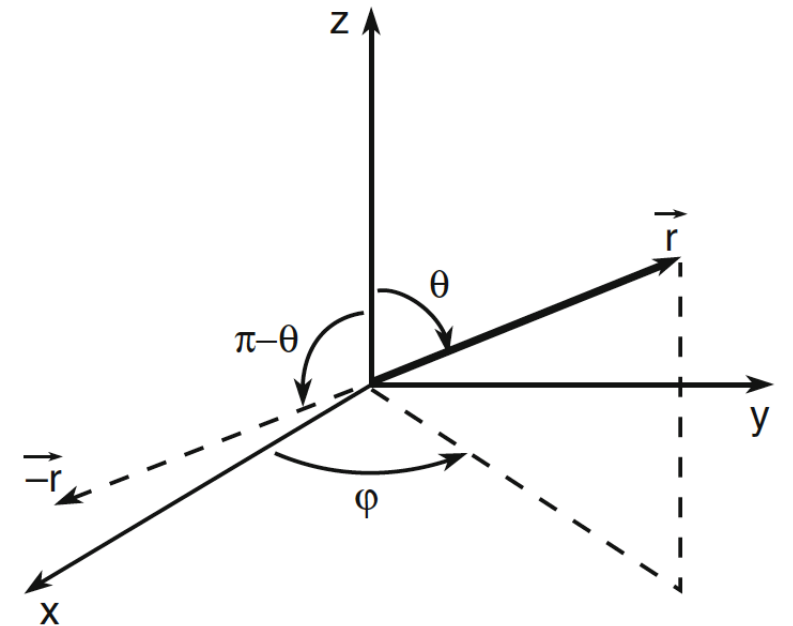



# Bound States in Atomic Physics: Parity (.. But Why?)

## Spatial function x Spin function

An example from atomic physics bound states: *Spin neglected*

$$P_n(x) = (2^n n!)^{-1} \frac{d^n}{dx^n} [(x^2 - 1)^n]$$

$$\psi(r, \theta, \varphi) = \chi(r) Y_\ell^m(\theta, \varphi)$$

$\ell$  = orbital quantum number

$m$  = azimuthal quantum number

$$Y_\ell^m(\theta, \varphi) =$$

Spherical harmonics

$$\sqrt{\frac{(2\ell + 1)(\ell - m)!}{4\pi(\ell + m)!}} P_\ell^m(\cos \theta) e^{im\varphi}$$

Legendre polynomials

The space inversion in this case gives:  $r \rightarrow -r$ ,  $\Theta \rightarrow \pi - \Theta$  and  $\phi \rightarrow \phi + \pi$

Reminder:  $\cos(\theta) = -\cos(\pi - \theta)$

If we apply the parity operator  $P$  to both Legendre polynomials and to the  $e^{im\varphi}$  term  $P =$  parity operator

$$P_0(x) = 1$$

$$P_1(x) = x$$

$$P_2(x) = \frac{1}{2}(3x^2 - 1)$$

$$P_3(x) = \frac{1}{2}(5x^3 - 3x)$$

$$P_4(x) = \frac{1}{8}(35x^4 - 30x^2 + 3)$$

$$P_5(x) = \frac{1}{8}(63x^5 - 70x^3 + 15x)$$

$$P_6(x) = \frac{1}{16}(231x^6 - 315x^4 + 105x^2 - 5)$$

Reminder! Please note that  $e^{ix} = \cos(x) + i \sin(x)$

$$P e^{im\varphi} = e^{im(\varphi + \pi)} = e^{im\pi} e^{im\varphi} = (-1)^m e^{im\varphi}$$

$$P P_\ell^m(\cos \theta) = (-1)^{\ell + m} P_\ell^m(\cos \theta)$$

$$P Y_\ell^m(\theta, \varphi) = (-1)^{\ell + m} Y_\ell^m(\theta, \varphi). \quad (-1)^{m+m} = 1$$



# $Exp(i\phi)$

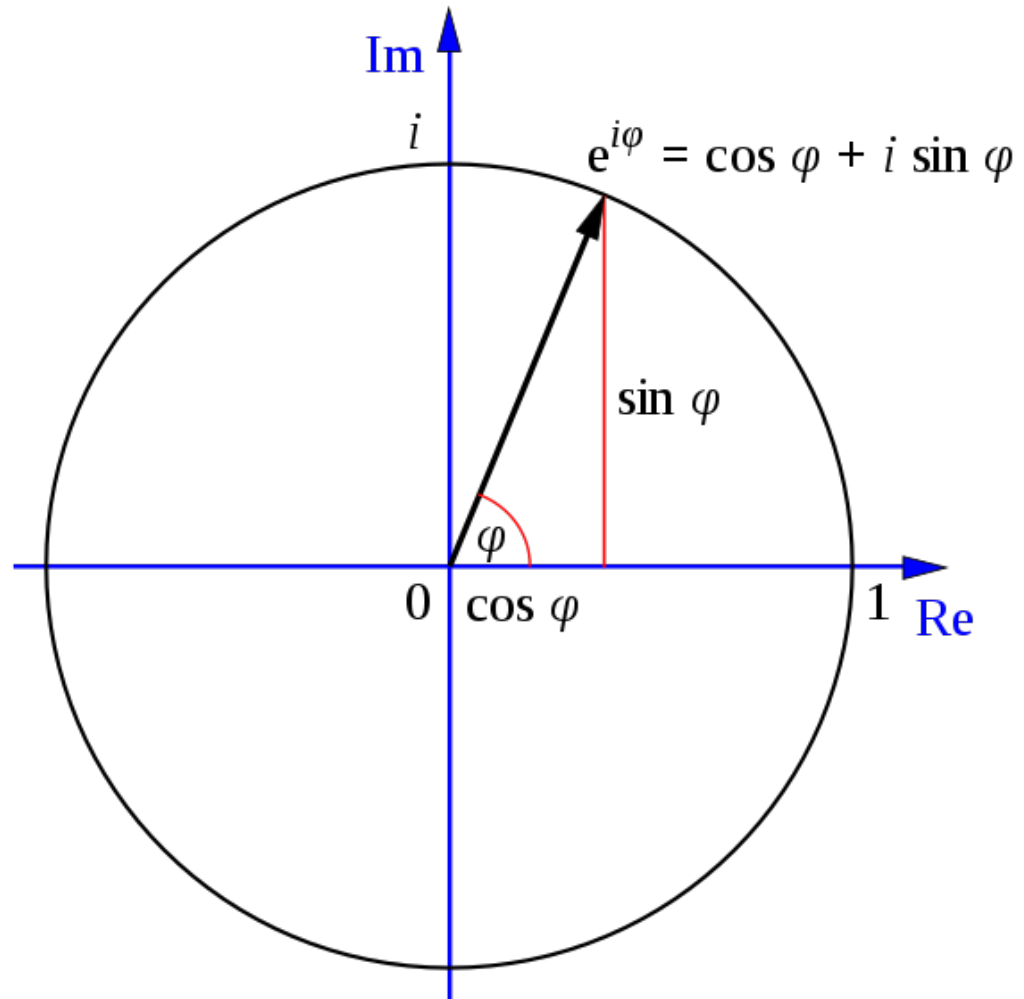



# Hydrogen Atom (*.. But Why?*)

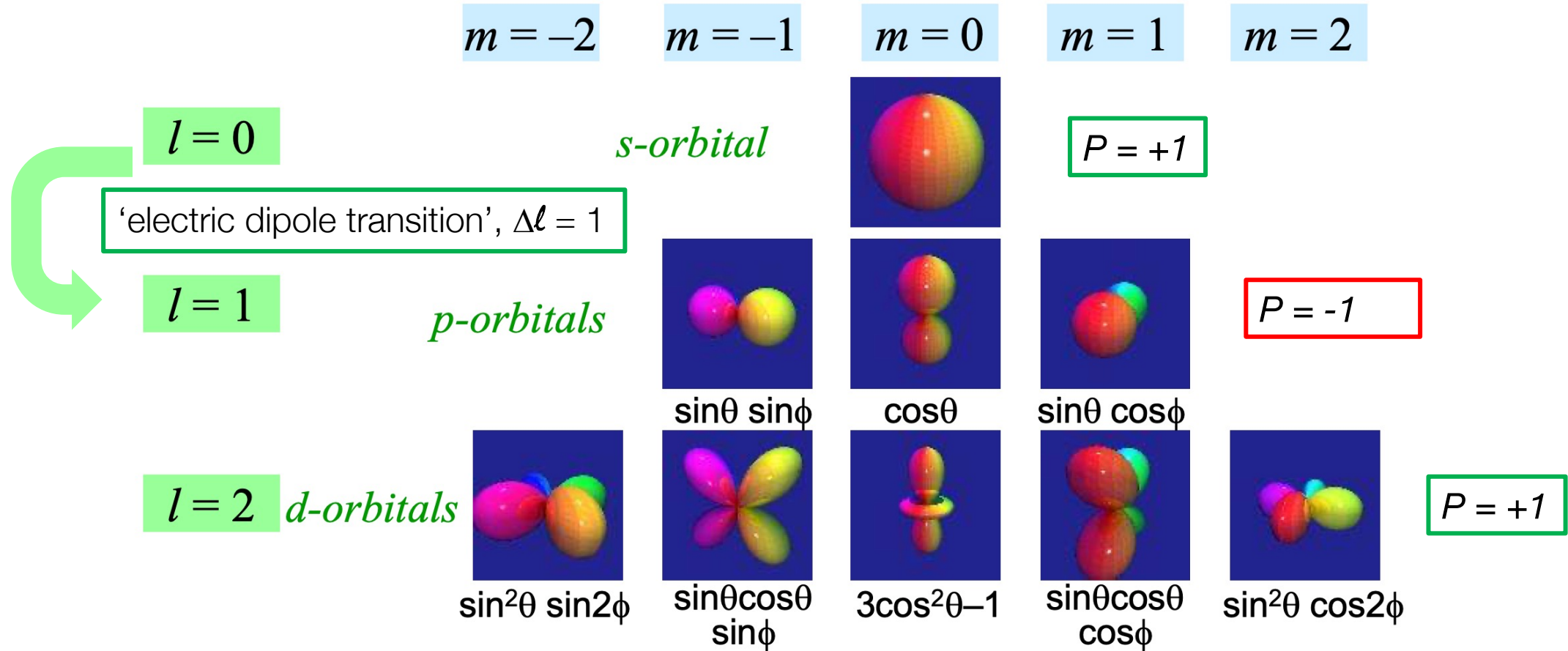

In 'electric dipole transitions' in the hydrogen atom,  $\Delta l = 1$ , a photon is emitted

- The parity of the atom changes
- To conserve the parity of the total system (hydrogen atom + photon)

Naming:  $J^P = \text{Spin}^{\text{Parity}}$   
 Photon  $\rightarrow J^P = 1^{-1}$

Photon must have parity -1



# Parity Violation in Weak Interactions

The electron neutrino has spin = 1/2 → has (in principle!) two polarization states ±1/2

Experimental finding: the spin of the electron neutrino is always anti-parallel to the direction of the momentum “left-handed” while the spin of the electron anti-neutrino always points in the same direction of the momentum “right-handed”

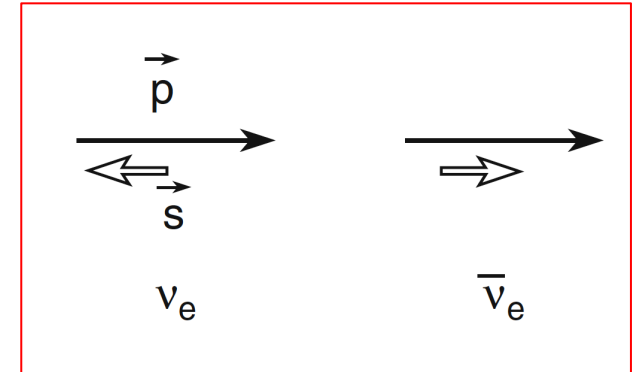

Parity transformation changes the momentum but not the spin. If applied to an electron neutrino would create a right-handed electron neutrino

$$P(\vec{p}, \vec{s}, \nu_e) = (\vec{p}, \vec{s}, \nu_e)$$

inverts the coordinates  
does not change time  
as a consequence  
it inverts momenta  
and does not change angular momenta  
including spins

$$\begin{aligned} \mathbf{r} &\Rightarrow -\mathbf{r} \\ t &\Rightarrow t \\ \mathbf{p} &\Rightarrow -\mathbf{p} \\ \mathbf{r} \times \mathbf{p} &\Rightarrow \mathbf{r} \times \mathbf{p} \\ \mathbf{s} &\Rightarrow \mathbf{s} \end{aligned}$$

Since the neutrino only has weak interactions and since the electron neutrino is ONLY left-handed then

Parity is not conserved in weak interactions







# Charge Conjugation in Particle Physics

C, charge conjugation, changes particles into antiparticles and vice versa, leaving space coordinates, time and spin unchanged. Therefore, the signs of all the additive quantum numbers, electric charge, baryon number and lepton number are changed.

- Its eigenvalues are  $\pm 1$ ; they are multiplicatively conserved in strong and e.m. interactions.
- Only particles (like  $\pi^0$ , unlike K's) which are their own antiparticles, are eigenstates of  $\mathbf{C}$ , with values  $C = (\pm 1)$  :
  - $C = -1$  for  $\gamma$  (accelerated charged particles emit photons; C changes the sign of the particle  $\rightarrow$  the photon must compensate!
  - $C = +1$  for  $\pi^0$  ( $\pi^0 \rightarrow \gamma\gamma$ ),  $\eta$ ,  $\eta'$ ;
  - $C = -1$  for  $\rho^0$ ,  $\omega$ ,  $\phi$ ;

- Why define  $\mathbf{C}$  ?  $\rightarrow$

*C-conservation constraints e.-m. decays:*

$$\pi^0 \rightarrow \gamma\gamma \quad : +1 \rightarrow (-1) (-1) \quad \text{ok;}$$

$$\pi^0 \rightarrow \gamma\gamma\gamma \quad : +1 \rightarrow (-1) (-1) (-1) \quad \text{no.}$$

$\text{Br}(\pi^0 \rightarrow \gamma\gamma\gamma)$  measured to be  $\sim 10^{-8}$ .



# Time Reversal

The time reversal operator  $T$  reverses the time coordinate  $t$  :

$$T t = -t$$

In *classical mechanics*, the systems are invariant under time reversal:

$$T \psi(\mathbf{r}, t) = \psi(\mathbf{r}, -t)$$

- planet moving on a circular orbit around the sun = planet following the same orbit in opposite direction (depending on the initial conditions).
- Similarly, the application of  $T$  to a two body scattering process would reverse the reaction:

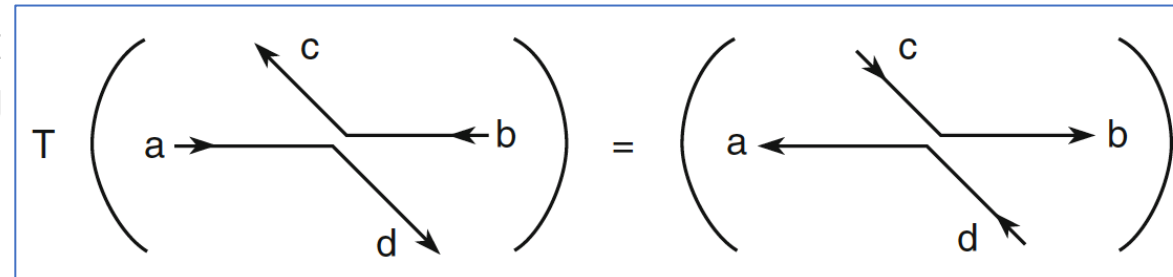

If the parity  $P$  (or  $T$ ) is conserved  $\rightarrow$  the Hamiltonian must not contain terms that change sign due to  $P$  or  $T$ .

$\rightarrow$  particles with spin may have a magnetic dipole moment, but not a static electric dipole moment (as in ordinary matter) because the term is not invariant under  $T$ .

Quantity	Transformation		
	$P$	$T$	
$\mathbf{r}$	$-\mathbf{r}$	$\mathbf{r}$	Polar vector
$\mathbf{p}$	$-\mathbf{p}$	$-\mathbf{p}$	Polar vector
$\sigma$	$\sigma$	$-\sigma$	Axial vector (like $\mathbf{L} = \mathbf{r} \times \mathbf{p}$ )
$\mathbf{E}$	$-\mathbf{E}$	$\mathbf{E}$	Remember that $\mathbf{E} = -\partial\phi/\partial\mathbf{r}$
$\mathbf{B}^a$	$\mathbf{B}$	$-\mathbf{B}$	$\mathbf{B}$ is similar to $\sigma$

<sup>a</sup>We can think of  $\mathbf{B}$  as being due to the current in a coil. Reversing  $T$  means to invert the current direction and therefore the magnetic field direction



# Invariance Properties of Fundamental Interactions

Additive (A) or Multiplicative (M) quantum number

Continuous Symmetries



Discrete Symmetries

Conservation of	Interaction			<i>N</i>
	Strong	Electromagnetic	Weak	
Energy–Momentum $E; \mathbf{p}$	yes	yes	yes	A
Angular momentum $\mathbf{J}$	yes	yes	yes	A
Parity $P$	yes	yes	no	M
Baryonic number $B$	yes	yes	yes	A
Leptonic numbers <sup>b</sup> $L_e, L_\mu, L_\tau$	yes	yes	yes	A
Electric charge $Q$	yes	yes	yes	A
Charge conjugation $C$	yes	yes	no	M
Time reversal $T$	yes	yes	yes <sup>a</sup>	M
$CP$	yes	yes	yes <sup>a</sup>	M
$CPT$	yes	yes	yes	M
Strong isospin $I$	yes	no	no	A
3 <sup>rd</sup> isospin component $I_z$	yes	yes	no	A
Strangeness $S$	yes	yes	no	A
Lifetime	$\sim 10^{-23}$ s	$\sim 10^{-20}$ s	$\sim 10^{-12}$ s	–
Interaction range	$\sim 10^{-13}$ cm	infinite	$< 10^{-15}$ cm	–

Will see later!



# CP and CPT

Weak interactions violate C and P. However they were (believed to be) invariant under the CP transformation

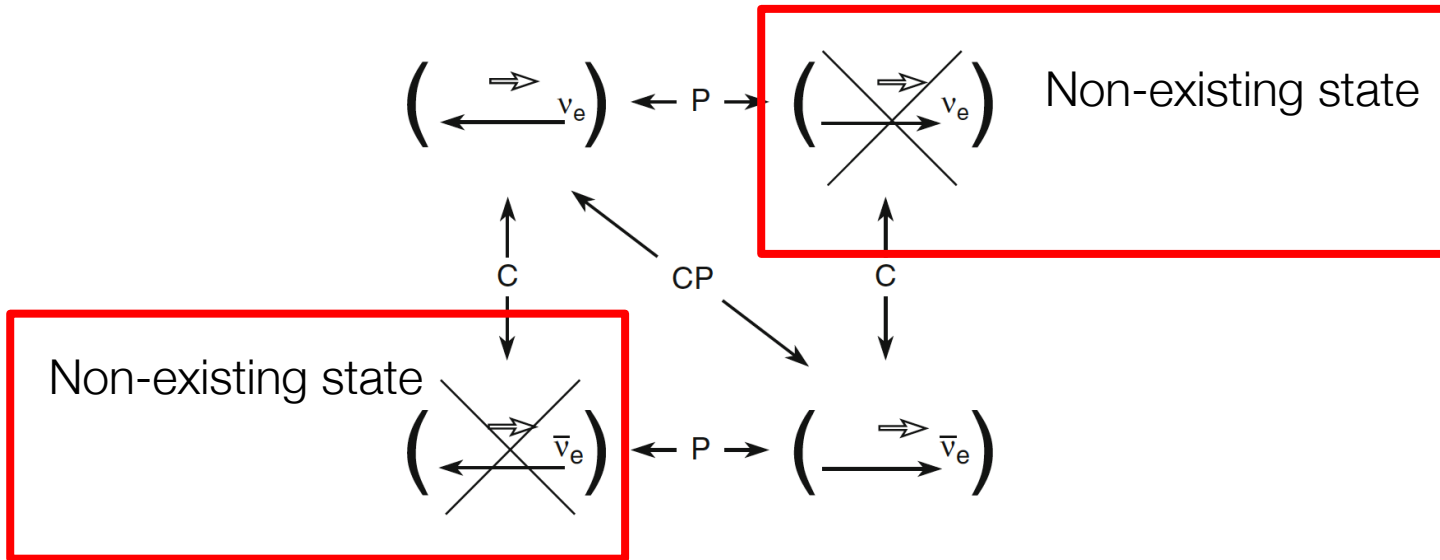

In '60 a rare decay of a neutral Kaon was discovered which was violating CP. A very small effect ( $\rightarrow$  rare decay!)  $\rightarrow$  important consequence in the evolution of the Universe:

- At the time of Big Bang the number of particles = the number of anti-particles
- Due to CP violation the number of particles became slightly larger than the number of anti-particles
- Annihilations left only particles in excess  $\rightarrow$  Universe is made of particles

However the invariance under CPT transformations is a fundamental property of quantum field theories  
 $\rightarrow$  the CP violation also involves a violation of T to maintain this symmetry



# Isospin, a new Quantum Number

- $m_p \approx m_n ; \sigma_{pp} \approx \sigma_{pn}$
- If you exchange  $n \leftrightarrow p$  in Nuclei they remain very similar:  ${}^7\text{Li}(3p + 4n) \approx {}^7\text{Be}(4p + 3n)$ ,  ${}^{13}\text{C}(6p + 7n) \approx {}^{13}\text{N}(7p + 6n)$

In ~1930 Heisenberg, Condon and Carren made the hypothesis:  
proton and the neutron are *two different states of the nucleon*.

→ A new quantum number: the *Isospin*,  $I$ . The nucleon was chosen to have  $I=1/2 \rightarrow I_3$  projections:  
the proton (+1/2) and the neutron (-1/2)

baryons	$m(\text{MeV}/c^2)$	$B$	$Q$	$S$	mesons	$m(\text{MeV}/c^2)$	$B$	$Q$	$S$
$p$	938.272	+1	+1	0	$K^+$	493.68	0	+1	+1
$n$	939.565	+1	0	0	$K^0$	497.65	0	0	+1
$\Lambda$	1115.68	+1	0	-1	$\eta$	547.7	0	0	0
$\Sigma^+$	1189.4	+1	+1	-1	$\pi^+$	139.570	0	+1	0
$\Sigma^0$	1192.6	+1	0	-1	$\pi^0$	134.977	0	0	0
$\Sigma^-$	1197.4	+1	-1	-1	$\pi^-$	139.570	0	-1	0
$\Xi^0$	1314.8	+1	0	-2	$\bar{K}^0$	497.65	0	0	-1
$\Xi^-$	1321.3	+1	-1	-2	$K^-$	493.68	0	-1	-1

Isospin combines like the spin:  
for a value  $I$  of the Isospin you  
have  $(2I + 1)$  possible  
combinations  $\rightarrow I_3$  values.  
 $0 \rightarrow$  singlet  
 $1/2 \rightarrow$  doublet  
 $1 \rightarrow$  triplet  
The state  $np$  ( $I_3=+1/2-1/2$ ) may  
belong to a singlet or triplet



# Isospin and Symmetry of Wave Functions

A rotation in the space of the Isospin does not change the state, Isospin is a conserved quantity in strong interactions (but not in weak and electro-weak). Mass differences are only due to EM interactions

If you have a nucleus with  $Z$  protons and  $N$  neutrons the projection of the Isospin will be

$$I_3 = \frac{1}{2}Z - \frac{1}{2}N = \frac{(Z-N)}{2}$$

Considering that the baryon number is  $B = Z + N$  and that the charge is  $Q = Z$  one can write

$$Q = I_3 + B/2$$

Isospin has to be considered when studying the symmetry of a pair of fermions:

$$\Psi = \psi(\text{Space})\chi(\text{spin})I(\text{Isospin})$$

$$\text{Space} \rightarrow -1^L$$

$$\text{Spin} \rightarrow -1^{S+1}$$

$$\text{Isospin} \rightarrow -1^{I+1}$$

The symmetry of a system with  $L, S, I$  goes like

$$\text{Symmetry} \rightarrow (-1)^L (-1)^{S+1} (-1)^{I+1}$$

A system with two nucleons has to be anti-symmetric as requested by the Pauli principle



# Mesons Isospin



baryons	$m(\text{MeV}/c^2)$	$B$	$Q$	$S$	mesons	$m(\text{MeV}/c^2)$	$B$	$Q$	$S$
$p$	938.272	+1	+1	0	$K^+$	493.68	0	+1	+1
$n$	939.565	+1	0	0	$K^0$	497.65	0	0	+1
$\Lambda$	1115.68	+1	0	-1	$\eta$	547.7	0	0	0
$\Sigma^+$	1189.4	+1	+1	-1	$\pi^+$	139.570	0	+1	0
$\Sigma^0$	1192.6	+1	0	-1	$\pi^0$	134.977	0	0	0
$\Sigma^-$	1197.4	+1	-1	-1	$\pi^-$	139.570	0	-1	0
$\Xi^0$	1314.8	+1	0	-2	$\bar{K}^0$	497.65	0	0	-1
$\Xi^-$	1321.3	+1	-1	-2	$K^-$	493.68	0	-1	-1

$$Q = I_3 + B/2$$

Protons and neutrons we saw already, all OK

Pion's masses are close by and may be considered as members of the same triplet with  $l=1$  and  $l_3=-1,0,1$ . Also the charges are correctly computed using the standard formula (baryon number=0)

The  $\eta$  has a mass very different from the pion's mass and it is ~isolated  $\rightarrow$  only member of a singlet. Charge is OK,  $l=0$ ,  $l_3=0$

$K^+K^0$  are also close in mass, like the pair  $K^-\bar{K}^0$ , may be assumed to be members of a doublet,  $l=1/2$ ,  $l_3=-1/2,1/2$ . However the Q formula fails.

All is restored if we include S, the *strangeness*, in the charge formula and define a new quantum number, the

$$\text{Hypercharge } Y = B + S$$

$$Q = I_3 + \frac{B + S}{2} = I_3 + \frac{Y}{2}$$



# Baryon Isospin

baryons	$m(\text{MeV}/c^2)$	$B$	$Q$	$S$	mesons	$m(\text{MeV}/c^2)$	$B$	$Q$	$S$
$p$	938.272	+1	+1	0	$K^+$	493.68	0	+1	+1
$n$	939.565	+1	0	0	$K^0$	497.65	0	0	+1
$\Lambda$	1115.68	+1	0	-1	$\eta$	547.7	0	0	0
$\Sigma^+$	1189.4	+1	+1	-1	$\pi^+$	139.570	0	+1	0
$\Sigma^0$	1192.6	+1	0	-1	$\pi^0$	134.977	0	0	0
$\Sigma^-$	1197.4	+1	-1	-1	$\pi^-$	139.570	0	-1	0
$\Xi^0$	1314.8	+1	0	-2	$\bar{K}^0$	497.65	0	0	-1
$\Xi^-$	1321.3	+1	-1	-2	$K^-$	493.68	0	-1	-1

$$Q = I_3 + \frac{B + S}{2} = I_3 + \frac{Y}{2}$$

Protons and neutrons we saw already, all OK

Baryons seem to be organised into multiplets as mesons: 1 singlet, 2 doublets, 1 triplet.  
The charge-formula works well for baryons!





# Extension to Other Generations ( $\rightarrow c, b, t$ quarks)

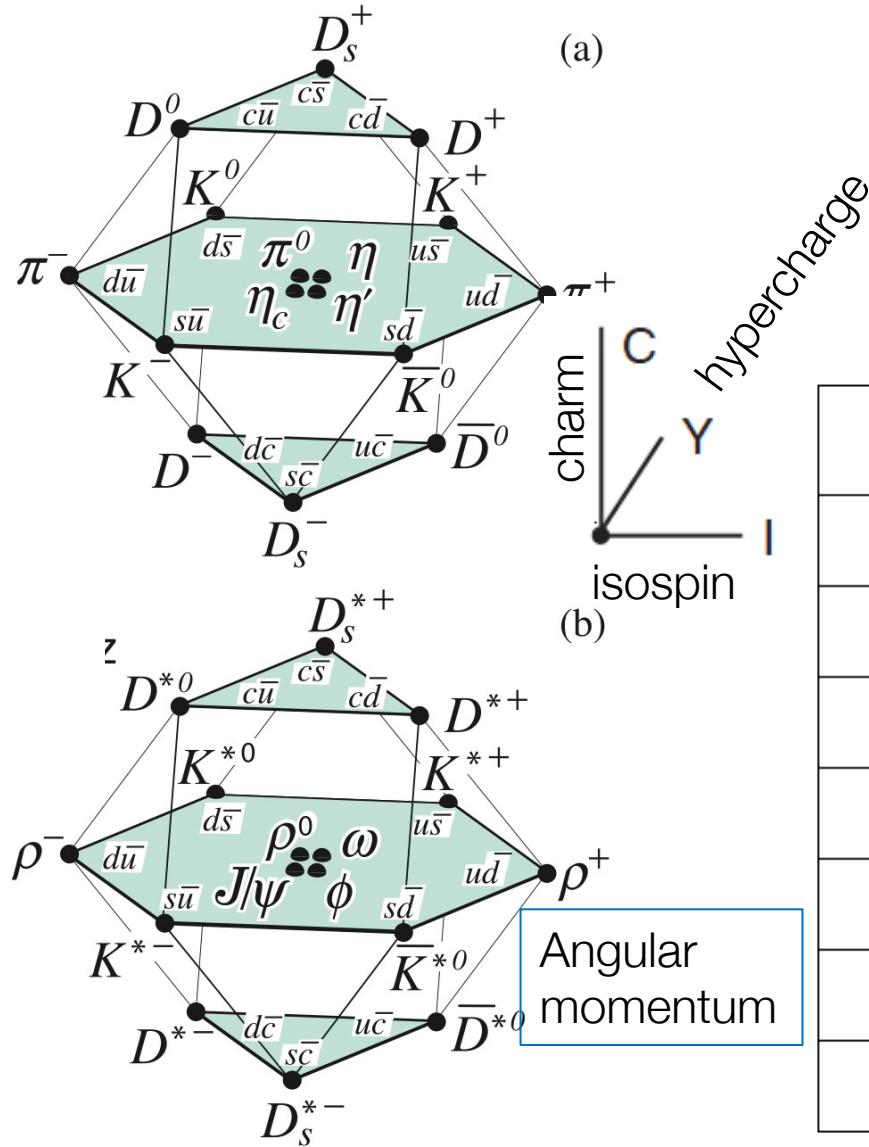

Generalised charge formula  $Q = I_z + \frac{B + S + C + B + T}{2}$

Baryon number  $\downarrow$   $Y$

Bottomness number  $\uparrow$

Property / Quark	$d$	$u$	$s$	$c$	$b$	$t$
Q – electric charge	$-\frac{1}{3}$	$+\frac{2}{3}$	$-\frac{1}{3}$	$+\frac{2}{3}$	$-\frac{1}{3}$	$+\frac{2}{3}$
I – isospin	$\frac{1}{2}$	$\frac{1}{2}$	0	0	0	0
$I_z$ – isospin z-component	$-\frac{1}{2}$	$+\frac{1}{2}$	0	0	0	0
S – strangeness	0	0	-1	0	0	0
C – charm	0	0	0	+1	0	0
B – bottomness	0	0	0	0	-1	0
T – topness	0	0	0	0	0	+1



# Life-time of Particles (.. the path to Resonances)

Stability of particles:

Stable particles: (...believed to be...) are:

- the photon  $\gamma$ ,
- the electron  $e^-$ ,
- neutrinos  $\nu$ .
- the proton (and the antiproton) (only stable hadron!)

(and the corresponding antiparticles)

In some models 'Beyond Standard Model' BSM also the proton and the neutrinos may be unstable.

Interaction	Life-time (s)	Comment	Example
Weak	$10^{-6}$ to $10^{-12}$	$\sim$ directly measurable	$\mu^- \rightarrow e^- \bar{\nu}_e \nu_\mu$
Electro-magnetic	$10^{-16}$ to $10^{-20}$		$\pi^0 \rightarrow \gamma\gamma$
Hadronic	$10^{-23}$	'Resonances' (more in the following!)	$\Lambda \rightarrow p\pi^-$
$W^+, W^-, Z^0$	$\sim 10^{-25}$	Decay is very fast due to large mass $\rightarrow$ light particles	$Z^0 \rightarrow \mu^+ \mu^-$

How to measure these short filetimes?



# Of the Uncertainty Principle

Sylvie Braibant, Giorgio Giacomelli, Maurizio Spurio:  
Particles and Fundamental Interactions

*Clarifications regarding the uncertainty principle. The uncertainty principle tells us that in Nature, a limit exists on our possible knowledge of the submicroscopic world, e.g., regarding the dynamics of a particle. For pairs of conjugated physics variables, for example, energy and time, momentum and position, there are limitations in the precision of their measurements. For example, if we measure the position  $x$  of an electron with a precision  $\Delta x$ , we cannot simultaneously measure the  $p_x$  component of its momentum with unlimited precision. According to the uncertainty principle, an uncertainty  $\Delta p_x$  related to the uncertainty  $\Delta x$  exists. Similarly,  $\Delta E$  and  $\Delta t$  are related through the uncertainty principle. In the literature, different numerical expressions for the uncertainty principle are used, that is,*

$$\Delta E \Delta t \geq \frac{\hbar}{2}, \quad \Delta E \Delta t \geq \hbar, \quad \Delta E \Delta t \geq h$$

$$\Delta p_x \Delta x \geq \frac{\hbar}{2}, \quad \Delta p_x \Delta x \geq \hbar, \quad \Delta p_x \Delta x \geq h.$$

$\Delta t, \Delta E, \Delta x, \Delta p$ : a measurement repeated many times will be in 67% of cases 'within'  $1 \Delta t, \Delta E, \Delta x, \Delta p$

Resonance (more in the following!):

$\Delta t$ , Lifetime  $\tau$   
 $\Delta E$ , Width  $\Gamma$   
 $\rightarrow \tau \Gamma \geq \hbar$

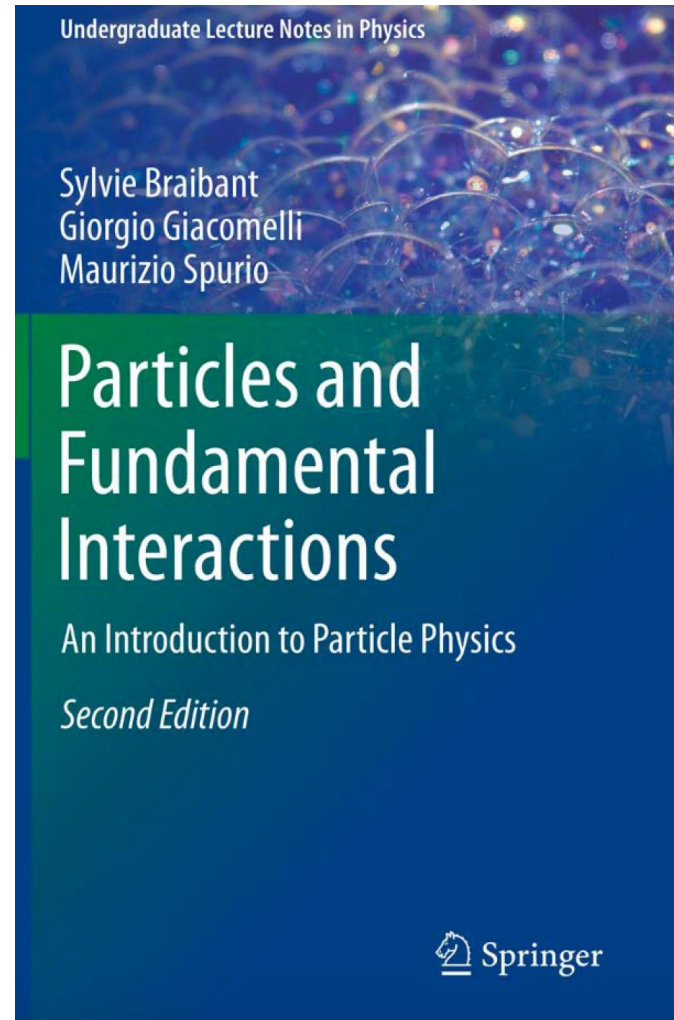



# Resonances and the Uncertainty Principle

The *Uncertainty Principle* relates pairs of conjugated physics variables:  
(energy and time), (position and momentum)

$$\Delta E \Delta t \geq \frac{\hbar}{2}$$

$$\Delta p_x \Delta x \geq \frac{\hbar}{2}$$

interaction of two particles  $a + b \rightarrow (R) \rightarrow a' + b'$   $R$ : unstable  $\rightarrow$  decays

Invariant mass  
 $a' + b' = m_R$

$R$ : possible intermediate state

Peak at the resonance  
mass

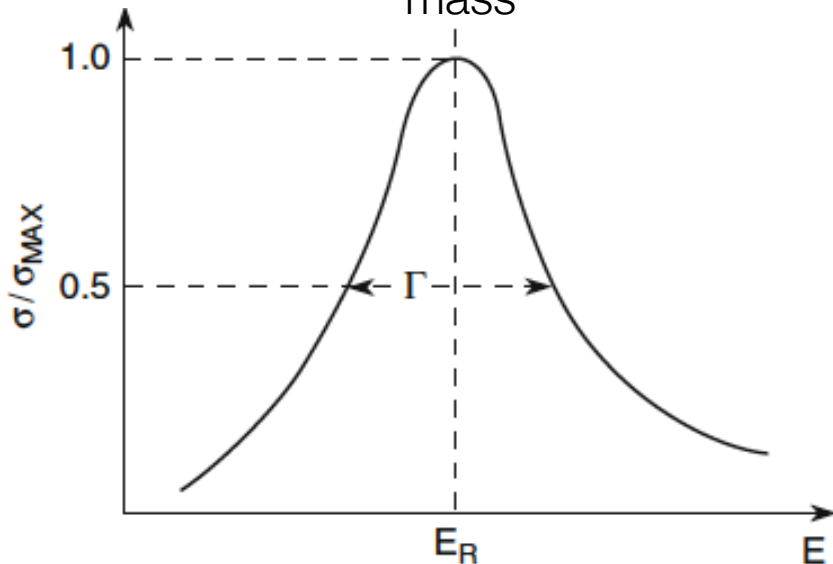

In the case of a resonance, we consider the energy (mass) and width  $\Gamma$  (uncertainty on the energy  $\rightarrow$  on the mass), lifetime of the particle at rest  $\tau$ .

$$\Delta E \sim \Gamma \quad \text{The width can be measured!}$$

$$\Delta t \sim \tau \quad \text{Too short to be measured!}$$

$$\rightarrow \Delta E \Delta t = \Gamma \tau \geq \frac{\hbar}{2}$$

- For a  $\Gamma \sim 100 \text{ MeV} \rightarrow \tau \sim 10^{-23} \text{ s}$
- If a resonance is produced with an energy  $E \rightarrow$  lifetime is increased by a factor  $\gamma = E/m \rightarrow \tau \gamma$



# Hadronic Resonances

- a particle with  $\tau \geq 10^{-12} \text{ s}$  ( $\rightarrow$  weak interactions) travels enough to be detected.
- Hadron resonances  $\rightarrow$  strong interactions  $\rightarrow$  their life-time is so short that it cannot be measured.

How to get their life-time?  $\rightarrow \Delta E \Delta t = \Gamma \tau \geq \frac{\hbar}{2} \rightarrow$  repeated measurements of the mass will give different results.

The width of the distribution is connected to the life-time:  $\Gamma = \Delta M c^2 = \frac{\hbar}{2} / \tau$

Cross section maximal at the peak of the resonance

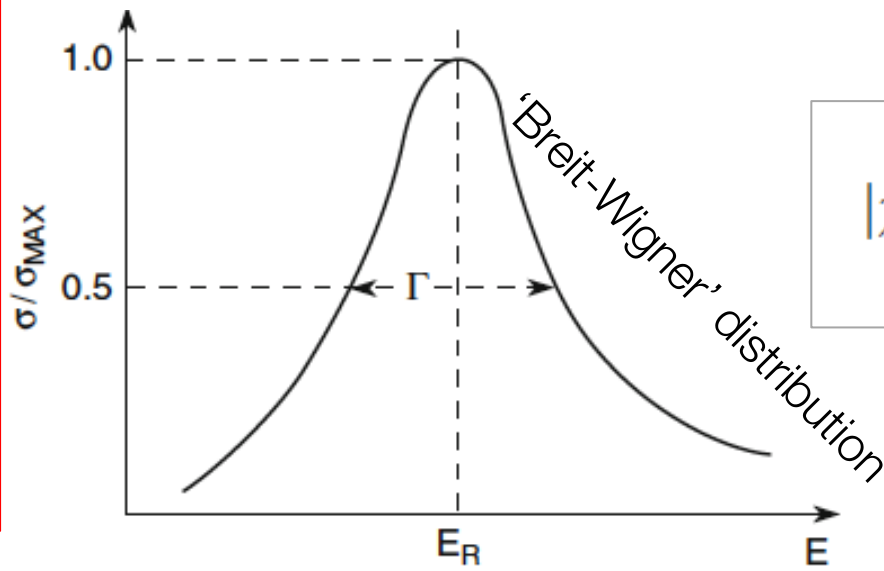

Measured resonance mass  
(inv.mass final state particles)

(Will derive this expression soon)

$$|\chi(Mc^2)|^2 \propto \frac{1}{(Mc^2 - M_0c^2)^2 + \frac{\Gamma^2}{4}}$$

Measured mass value      Resonance mass value      Resonance width  $\Gamma$

A width of  $\sim 100$  MeV corresponds to a life-time of  $10^{-23} \text{ s}$   $\rightarrow$  much too short to be measured!

The presence of a resonance is signalled by increase of cross section !!!!



# Getting the Breit Wigner Shape

Intermediate excited states may show up in hadronic interactions. These states  $R$  are called resonances.  $\rightarrow$  described by a wave function with a de Broglie  $\lambda = \frac{h}{p} = \frac{2\pi\hbar}{pc}$  and described by a wave-function like

$$\psi(t) = \psi(0)e^{-\frac{iE_R}{\hbar}t}$$

This state is unstable and will decay to  $a'$  and  $b'$   $\rightarrow$  **decay law**

Elastic scattering case  $\rightarrow$  same particles of the initial state also in the final state (but different momenta)

Ideal Experiment:

  
Beam  $a$  of variable energy



Target containing  $b$  (at rest)



If you increase the energy of particle  $a$  an intermediate state  $R$  may be produced  $\rightarrow$  increase in the cross section.

$dP$  = probability of decay per unit time

$N$  = number of produced resonances

$\rightarrow -dN = \lambda N dt$  where  $\lambda$  is a constant that describes how quickly the resonance decays.

$$N(t) = N_0 e^{-\lambda t} = N_0 e^{-t/\tau}$$



# Getting the Breit Wigner Shape

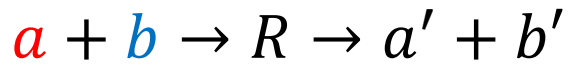

Scattering  $\rightarrow$  2 particles in the final state

Elastic scattering  $\rightarrow$  same particles of the initial state

$$1 \quad \psi(0)e^{-i\omega_R t}$$

free particle wave function

$$2 \quad N(t) = N_0 e^{-t/\tau}$$

decay probability vs time

$$\psi(t) = \psi(0)e^{-i\omega_R t} \cdot e^{-t/2\tau} = \psi(0)e^{-iE_R t/\hbar} \cdot e^{-t \cdot \Gamma/2\hbar} \quad (\text{where } \omega_R = \frac{E_R}{\hbar} \text{ and } \tau = \frac{\hbar}{\Gamma})$$

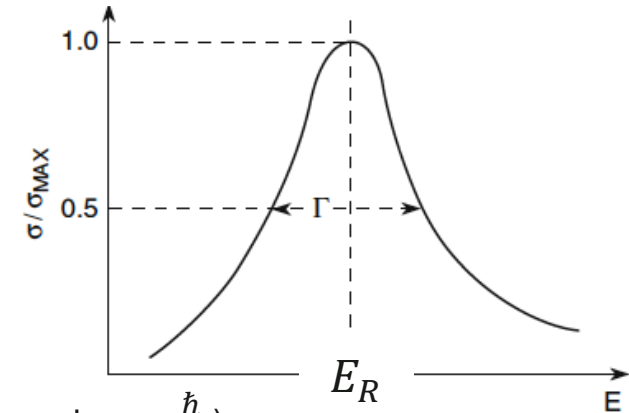

The probability  $I(t)$  of finding the resonance decay at a time  $t$  is

$$I(t) = \psi^* \psi = \psi(0)^2 \cdot e^{-\frac{t}{\tau}}$$

$$I(t) = I(0) \cdot e^{-\frac{t}{\tau}} \quad \text{Exponential life-time}$$

Which is the probability  $\chi(E)$  of producing a resonance with energy  $E$ ?  $\rightarrow$  Do a Fourier transform

The Fourier transform is a transformation that decomposes functions depending on space or time into functions depending on spatial or temporal frequency  $\rightarrow$  in our case (resonance) gives us the energy distribution

$$\chi(E) = \int \psi(t) e^{iEt} dt = \psi(0) \int e^{-iE_R t/\hbar} \cdot e^{-\Gamma/2\hbar} e^{iEt} dt$$



# Relation between Width and Cross Section

$$\chi(E) = \int \psi(t) e^{iEt} dt = \psi(0) \int e^{-iE_R t/\hbar} \cdot e^{-\Gamma/2\hbar} e^{iEt} dt$$

(Let's remember that  $\int_0^\infty e^{-ax} dx = \frac{1}{a}$ )

$$\rightarrow \chi(E) = \frac{\text{Constant}}{(E_R - E) - i\Gamma/2}$$

We have put  $\hbar = 1$

Maximum at  $E=E_R$

$$\sigma(E) = \sigma_0 \cdot \chi^*(E) \cdot \chi(E) = \sigma_0 \cdot \frac{\text{Constant}^2}{[(E_R - E)^2 + \Gamma^2/4]}$$

The *Constant* has to be related to the cross section: the square of the wave function  $\chi(E)$  represents the probability of finding the particle in the energy state E, it must be proportional to the process cross-section, that is

$$\sigma_0 \sim \text{wave - length}^2 \sim 4\pi\lambda^2 \propto 1/p^2$$

$$\sigma(E) \sim 4\pi\lambda^2 \cdot \frac{\text{Constant}^2}{[(E_R - E)^2 + \Gamma^2/4]}$$

Maximum at  $E_R \rightarrow$  we can write

$$1 = \chi^*(E_R) * \chi(E_R) = \frac{\text{Constant}^2}{\Gamma^2/4} \rightarrow \text{Constant}^2 = \frac{\Gamma^2}{4}$$

Breit – Wigner formula (sometimes used as synonym of ‘resonance’)

$$\sigma(E) = 4\pi\lambda^2 \frac{\Gamma^2/4}{(E_R - E)^2 + \Gamma^2/4}$$

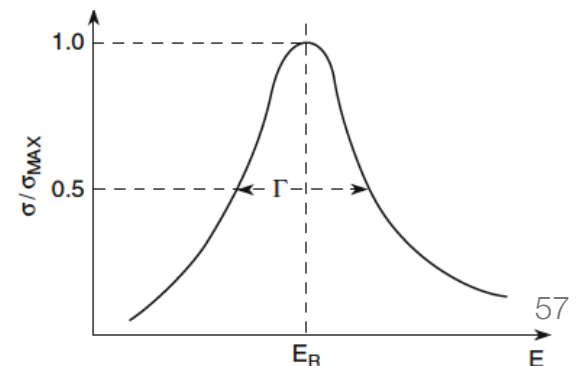





# Taking Spin into account

Resonance with spin  $J$  produced by the collision of two particles  $a, b$ , with spin  $s_a, s_b$

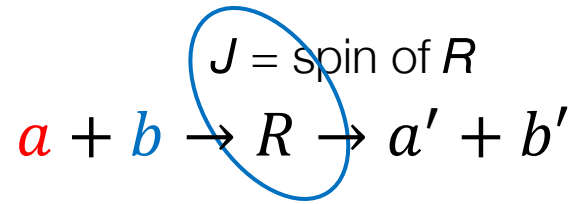

Spin sub-states of the resonance:  $(2J + 1)$

Spin sub-states the initial state:  $(2s_a + 1)(2s_b + 1)$

→ The cross-section must be averaged over the number of spin states of the incoming particles and multiplied by a factor  $(2J + 1)$

$$\sigma(E) = 4\pi\lambda^2 \frac{(2J + 1)}{(2s_a + 1)(2s_b + 1)} \frac{\Gamma^2/4}{(E_R - E)^2 + \Gamma^2/4}$$

- The measurement of the cross section also allows to constraint the spin of the resonance.
- Spins of the incoming particles are known → Factor  $(2J+1)$  gives the spin of the resonance



# One observation for inelastic collisions

What we said is valid in the elastic case when particles in the final state are the same of the initial state



$$\sigma(E) = 4\pi\lambda^2 \frac{(2J + 1)}{(2s_a + 1)(2s_b + 1)} \frac{\Gamma^2/4}{(E_R - E)^2 + \Gamma^2/4}$$

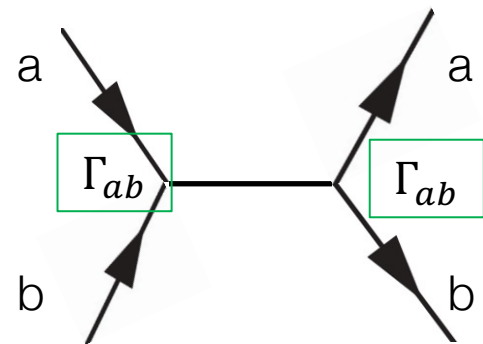

Elastic case

$\Gamma^2$  is ok for the elastic case because you have the same particles in the initial and final state  
 $\Gamma$  tells us how strongly  $R$  couples to  $(ab)$  once in the initial state and once in the final state

$$\rightarrow \Gamma_{ab} \cdot \Gamma_{ab} \rightarrow \Gamma^2$$

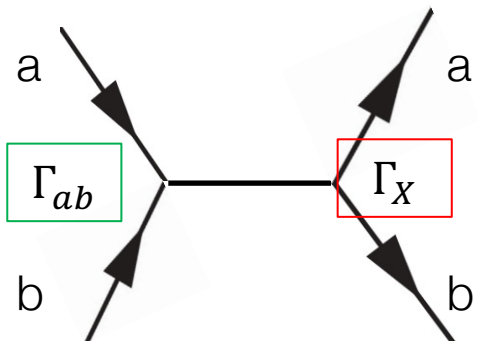

Inelastic case

In the inelastic case  $a + b \rightarrow R \rightarrow X$  ('many particles')

$$\rightarrow \Gamma_{ab} \cdot \Gamma_X$$

In the inelastic case you may have different decays  $\rightarrow$  define different 'Branching fractions'



# Resonance : $\sigma_R$ Inelastic Case

$$\sigma_0 \sim \text{wave length}^2, \lambda = \frac{h}{p} = \frac{2\pi\hbar}{pc}$$

$$E_{CM}^{target} = \sqrt{s} = \sqrt{2E_{beam} \cdot m_2}$$

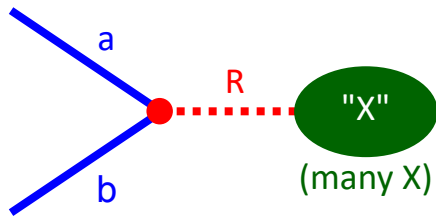

- $(E, \vec{p})$ : CM 4-mom.
- $\Gamma_R$  : constant width
- $\Gamma_{ab, X}$  : couplings
- $M_R$  :  $E_0$ , mass

$$\sigma_{ab \rightarrow R \rightarrow X}(E_{CM} = \sqrt{s}) = \frac{\pi}{|\vec{p}_{a,b}|^2} \frac{(2J_R + 1)}{(2S_a + 1)(2S_b + 1)} \frac{\Gamma_{ab}\Gamma_X}{(\sqrt{s} - M_R)^2 + \Gamma_R^2/4} \approx$$

$$\approx \left[ \frac{16\pi}{s} \right] \left[ \frac{(2J_R + 1)}{(2S_a + 1)(2S_b + 1)} \right] \left[ \frac{\Gamma_{ab}}{\Gamma_R} \right] \left[ \frac{\Gamma_X}{\Gamma_R} \right] \left[ \frac{\Gamma_R^2/4}{(\sqrt{s} - M_R)^2 + \Gamma_R^2/4} \right]$$

scale factor  
(1/s)

statistical factor  
(particle spins)

= BR(R  $\rightarrow$  ab)

= BR(R  $\rightarrow$  X)

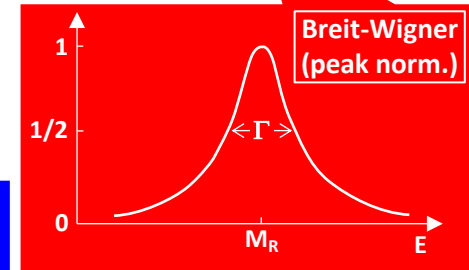

$$\sigma(e^+e^- \rightarrow J/\psi \rightarrow \mu^+\mu^-) = \left[ \frac{16\pi}{s} \right] \left[ \frac{3}{4} \right] \left[ \frac{\Gamma_{ee}}{\Gamma_{tot}} \right] \left[ \frac{\Gamma_{\mu\mu}}{\Gamma_{tot}} \right] \left[ \frac{(\Gamma_{tot}/2)^2}{(\sqrt{s} - M)^2 + (\Gamma_{tot}/2)^2} \right] =$$

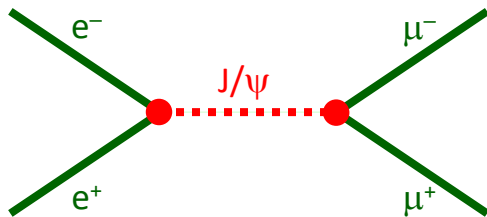

$$= \frac{12\pi}{s} \text{BR}_{J/\psi \rightarrow e^+e^-} \text{BR}_{J/\psi \rightarrow \mu^+\mu^-} \left[ \frac{(\Gamma_{tot}/2)^2}{(\sqrt{s} - M)^2 + (\Gamma_{tot}/2)^2} \right]$$

$e^+e^- \rightarrow J/\psi \rightarrow \mu^+\mu^-$   
 $\sigma_{\text{peak}} \propto 1/s$  ( $\approx M_R^{-2}$ ),  
 independent from coupling strength.



# Resonance : Different Functions

Many more parameterizations used in literature (semi-empirical or theory inspired), e.g.:

$$\sigma_0 = \left[ \frac{16\pi}{(2p)^2} \right] \left[ \frac{(2J_R + 1)}{(2S_a + 1)(2S_b + 1)} \right] \left[ \frac{\Gamma_{ab}}{\Gamma_R} \right] \left[ \frac{\Gamma_{final}}{\Gamma_R} \right] \left[ \frac{\Gamma_R^2/4}{(\sqrt{s} - M_R)^2 + \Gamma_R^2/4} \right]$$

original, non-relativistic

$$\sigma_1 = \left[ \frac{16\pi}{s} \right] \left[ \frac{(2J_R + 1)}{(2S_a + 1)(2S_b + 1)} \right] \left[ \frac{\Gamma_{ab}}{\Gamma_R} \right] \left[ \frac{\Gamma_{final}}{\Gamma_R} \right] \left[ \frac{\Gamma_R^2/4}{(\sqrt{s} - M_R)^2 + \Gamma_R^2/4} \right]$$

$m_a, m_b \ll p$

$$\sigma_2 = \left[ \frac{16\pi}{M_R^2} \right] \left[ \frac{(2J_R + 1)}{(2S_a + 1)(2S_b + 1)} \right] \left[ \frac{\Gamma_{ab}}{\Gamma_R} \right] \left[ \frac{\Gamma_{final}}{\Gamma_R} \right] \left[ \frac{\Gamma_R^2/4}{(\sqrt{s} - M_R)^2 + \Gamma_R^2/4} \right]$$

simpler, neglect s-dependence

$$\sigma_3 = \left[ \frac{16\pi}{M_Z^2} \right] \left[ \frac{3}{4} \right] \left[ \frac{\Gamma_{ee}}{\Gamma_Z} \right] \left[ \frac{\Gamma_{ff}}{\Gamma_Z} \right] \left[ \frac{M_Z^2 \Gamma_Z^2}{(s - M_Z^2)^2 + M_Z^2 \Gamma_Z^2} \right]$$

relativistic BW for  $e^+e^- \rightarrow Z \rightarrow ff$



$$\sigma_4 = \left[ \frac{16\pi}{M_Z^2} \right] \left[ \frac{3}{4} \right] \left[ \frac{\Gamma_{ee}}{\Gamma_Z} \right] \left[ \frac{\Gamma_{ff}}{\Gamma_Z} \right] \left[ \frac{s \Gamma_Z^2}{(s - M_Z^2)^2 + s^2 \Gamma_Z^2 / M_Z^2} \right]$$

"s-dependent  $\Gamma_Z$ " (used at LEP for the Z lineshape)

# Resonances: Practicalities

There are two mechanisms for the creation of resonances:

- Formation:** the two interacting particles have both quantum numbers and energy to produce a resonance.  $\rightarrow$  increase of the cross-section at an energy corresponding to  $M_R \rightarrow$  mass & width  $\rightarrow$  life-time  $\rightarrow$  **EASY!**
- Production:** the two interacting particles do **NOT** have the quantum numbers to create a resonance  $\rightarrow$  an intermediate virtual particle is needed (with correct quantum numbers!). Determining the presence of this resonance will be more **DIFFICULT**  $\rightarrow$ 
  - identify decay products of  $R$  (use 2 right particles out of 3)
  - construct of the invariant mass.

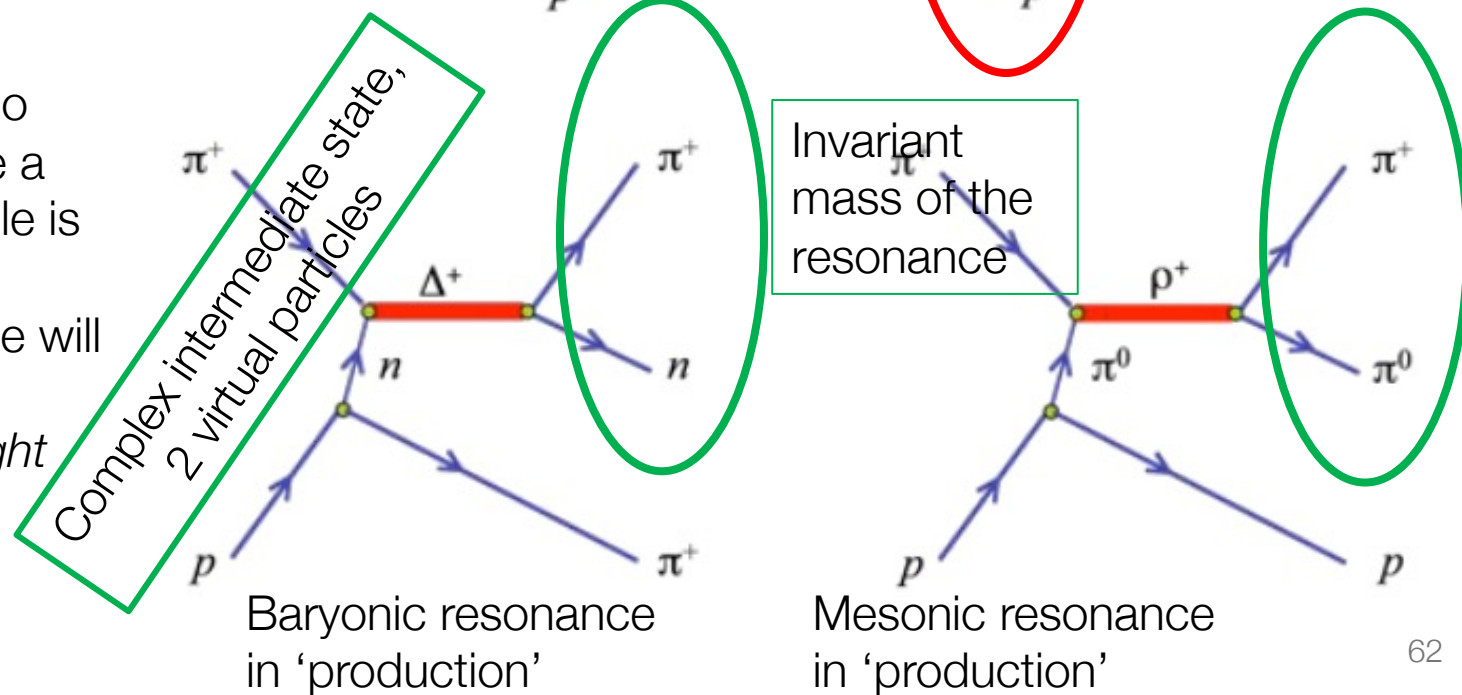
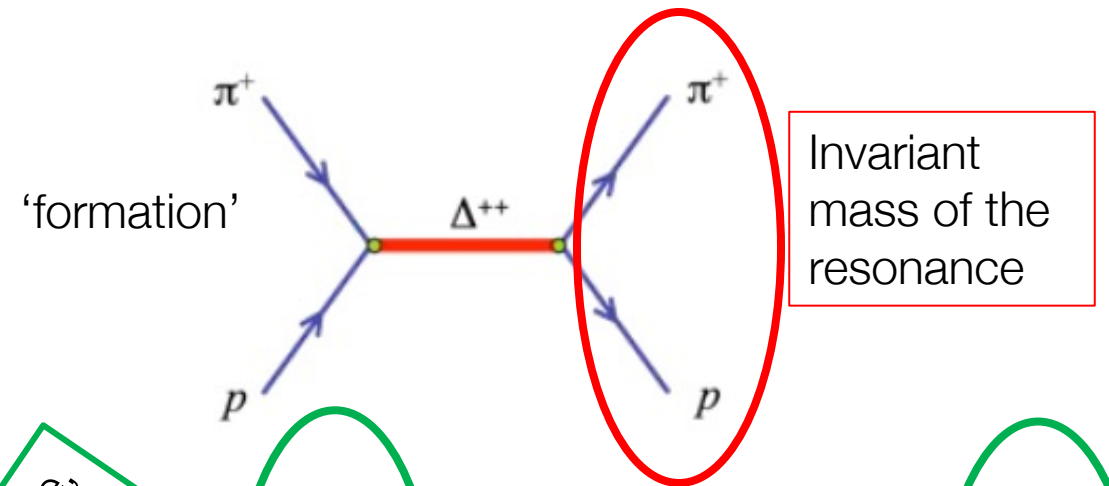



# The Electromagnetic Paradigm

- **Electromagnetic (EM):** The analytic form of the interaction potential between charged particles is precisely known → Maxwell's original formulation → relativistic representation → quantized field theory.
- **Quantum electrodynamics (QED):** includes the spin of particles, the interaction between charged particles through the exchange of a photon. Many physics quantities (cross-sections, particle lifetimes, magnetic moments, and so on) can be computed very precisely.
- QED extended to the weak and (partially) to the strong interactions → **comparison of theoretical predictions with experimental measurements**.
- electromagnetic and weak interactions are different manifestations of a single interaction, the electroweak interaction. The **unification** of the two interactions occurs at an energy  $\sim W^+, W^-$ , and  $Z^0$  masses  $\sim 100$  GeV. At lower energies, the electromagnetic and weak interactions are separate and different.
- At much larger energies, the electroweak and strong interaction unification (the so-called **Grand Unification Theory**) can be hypothesized.

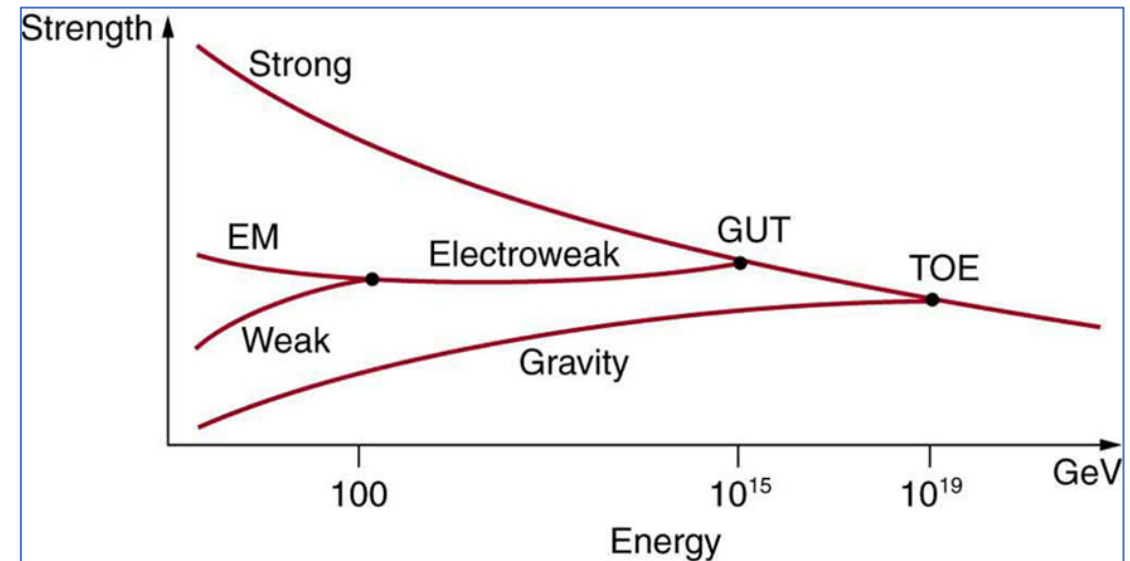



# The Electro-Magnetic Case

Classical Approach

Coulomb force:

$$F = K \frac{q_1 q_2}{r^2} \vec{r}$$

- $q_1$  e  $q_2$  are the point-like particle electric charges,
- $r$  is the distance between them,
- $\vec{r}$  is a unit vector directed from  $q_1$  to  $q_2$  (positive or negative) and
- $K$  is a proportionality constant. The dependence on  $r$  is similar to that of Newton's law.
- The *electrostatic force can attract or repel particles*, depending on the relative sign of the charges.

Magnetic field is generated by electric charges in motion; the force acting on a moving charge  $q$  with velocity  $\mathbf{v}$  in an electric field  $\mathbf{E}$  and a magnetic field  $\mathbf{B}$  is:

$$F = q\mathbf{E} + q\mathbf{v} \times \mathbf{B}. \text{ Classical approach: interaction between particle \& field}$$

Today's view: Graphic representation ( → Feynman diagrams) for the elastic electron–electron interaction.

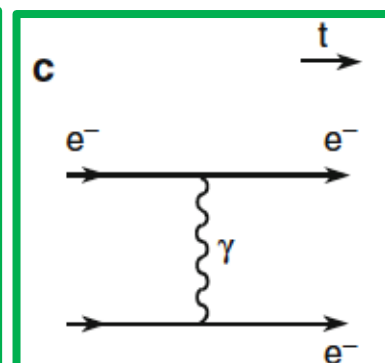
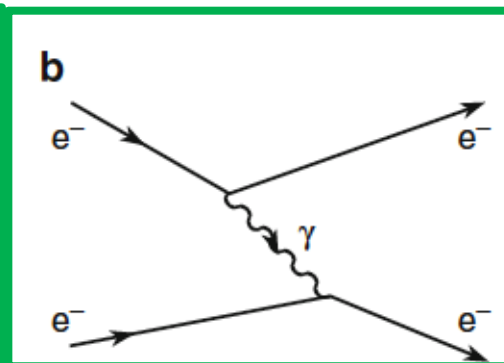
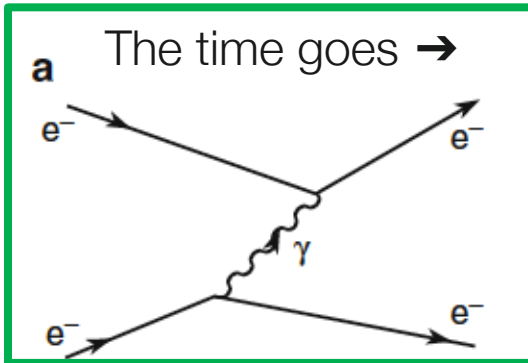

- (a), the electron in the bottom part emits a “virtual” photon which is then absorbed by the electron at the top;
- (b) the other way around.
- (c) the interaction without specifying who emits the photon



# The EM Case & Feynman Diagrams

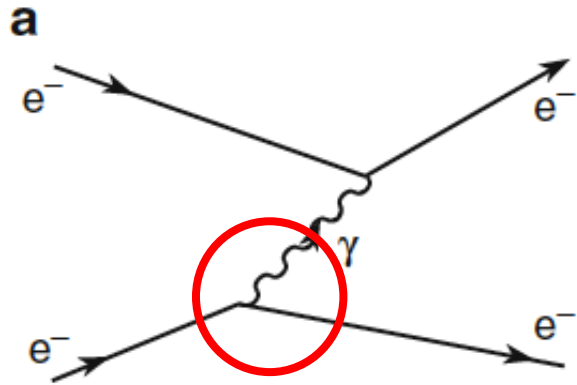

- Feynman diagrams have been very successful for describing the EM interactions.
  - both an intuitive representation of the interaction and
  - a rigorous way to obtain numerical quantities through a perturbative calculation method (see later)

The interaction between two electrons: they repel each other.  
The interaction happens through the exchange of a photon (in this case).

An electron at **rest** cannot, however, emit a “real” photon because this would violate the energy conservation law

Process	Initial state energy	Final state energy	
$e \rightarrow e\gamma$	$m_e c^2$	$\neq m_e c^2 + \frac{p_e^2}{2m_e} + E_\gamma$	(non relativistic case)

$E_\gamma$  is the total energy of the emitted photon,  $p_e$  is the (nonrelativistic) momentum acquired by the electron,  $m_e$  is the electron mass. According to Heisenberg’s uncertainty principle, if energy is measured with an uncertainty of  $\Delta E$ , the uncertainty on the time measurement is

$$\Delta t \geq \hbar / (\Delta E).$$





# The Nature of the Electromagnetic Interaction

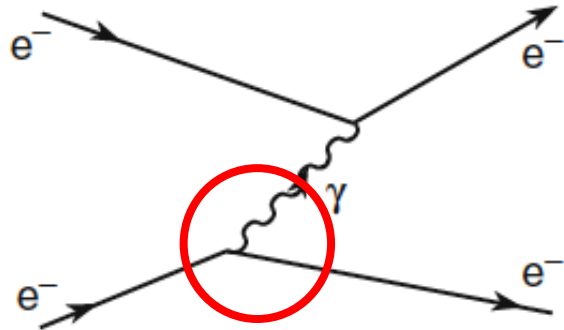

No solution??? Let's follow the time evolution of the process:

$$\Delta t \geq \hbar / (\Delta E).$$

- A photon is emitted from the first electron violating the energy conservation (by a quantity  $\Delta E$ ).
- The photon is absorbed by the second electron after a time  $t$ ,  $\rightarrow$  a second violation of energy conservation by a value of  $-\Delta E$ .
- If all this happens within  $\Delta t$  of the uncertainty principle, *the two violations cannot be observed*: they are “hidden” by the uncertainty principle.

*This process is considered as possible.*

*The net effect is an exchange of energy and momentum between the two electrons, and is therefore a way in which two electrons, and more generally two charged particles, can interact.*

The electron quantum numbers, particularly its spin, must remain unchanged.  $\rightarrow$

As a consequence, the exchanged particle must have *integer spin* and is therefore a boson (all the force mediators have spin 1, except the graviton that has spin 2).



# The Nature of the Electromagnetic Interaction

The photon is massless  $\rightarrow$  moving at the light speed, it travels in the time interval  $\Delta t$  a distance

$$\Delta r = c\Delta t$$

Placing this quantity in the uncertainty relation, one obtains

$$\Delta E \geq \hbar/(\Delta t) \approx \hbar c/(\Delta r).$$

Since the interaction energy  $V$  is of the order of  $\Delta E$  one has

$$\Delta E \simeq V = \alpha_i \hbar c/r.$$

The dimensionless constant  $\alpha_i$  gives the interaction intensity  $\rightarrow$  the forces due to the exchange of virtual massless particles decrease with the distance  $r$  as

$$F \sim dV/dr \sim 1/r^2$$

- From the opposite approach,  $1/r^2 \rightarrow$  the exchanged virtual particle is massless.
- Since the gravitational force has a similar dependence in  $1/r^2$ , the graviton should also be massless.

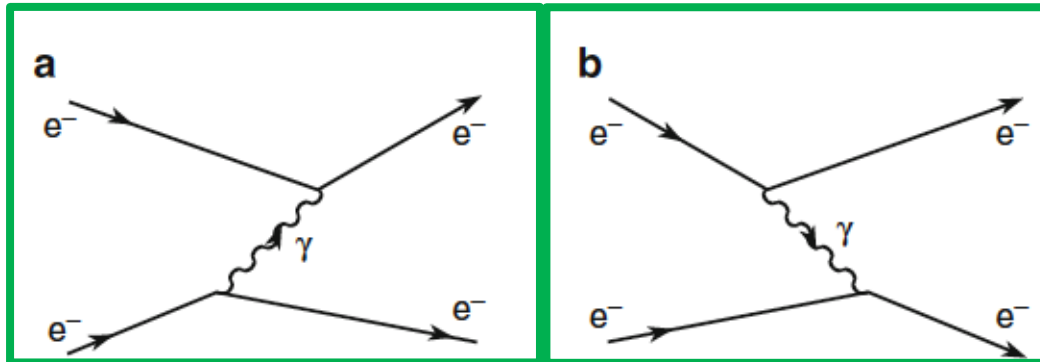

Comment:

Since the virtual field (the photon) is not observable, and since the final states are identical, we do not know if the photon is created (destroyed) by the electron at the top or at the bottom of the diagram: the two processes are indistinguishable.



# Elaborating more

The dimensionless parameter characteristic of the EM interaction is the fine structure constant (also called electromagnetic coupling constant) already known from atomic physics. It can be derived by equating

$$\Delta E \simeq V = \alpha_i \hbar c / r.$$

with the Coulomb energy potential:

$$\alpha_i \hbar c / r = K q^2 / r$$

from which one finds ( $q = e$  is the electric charge of the electron):

$$\alpha_i = e^2 / \hbar c$$

numerically, one has (S.I., cgs, cgs)

electromagnetic coupling constant

$$\mathbf{F}_1 = \frac{1}{4\pi\epsilon_0} \frac{q_1 q_2}{r_{12}^2} \mathbf{e}_{12} = -\mathbf{F}_2.$$

$$\alpha_{EM} = \frac{e^2}{4\pi\epsilon_0 \hbar c} = \frac{(1.602 \cdot 10^{-19})^2}{4\pi \cdot 8.85 \cdot 10^{-12} \cdot 1.05 \cdot 10^{-34} \cdot 3 \cdot 10^8} = \mathbf{1/137.1}$$

$$\alpha_{EM} = \frac{e^2}{\hbar c} = \frac{(4.803 \cdot 10^{-10})^2}{1.0546 \cdot 10^{-27} \cdot 3 \cdot 10^{10}} = \mathbf{1/137.1} = 7.294 \cdot 10^{-3}$$

$$\alpha_{EM} = \mathbf{e^2} \quad (\hbar = c = 1)$$

1/137 is a ~small number  $\rightarrow$   
the perturbation induced by the  
exchange of one photon is ~small

Will discuss more about it



# Micro to Macro world

Physics

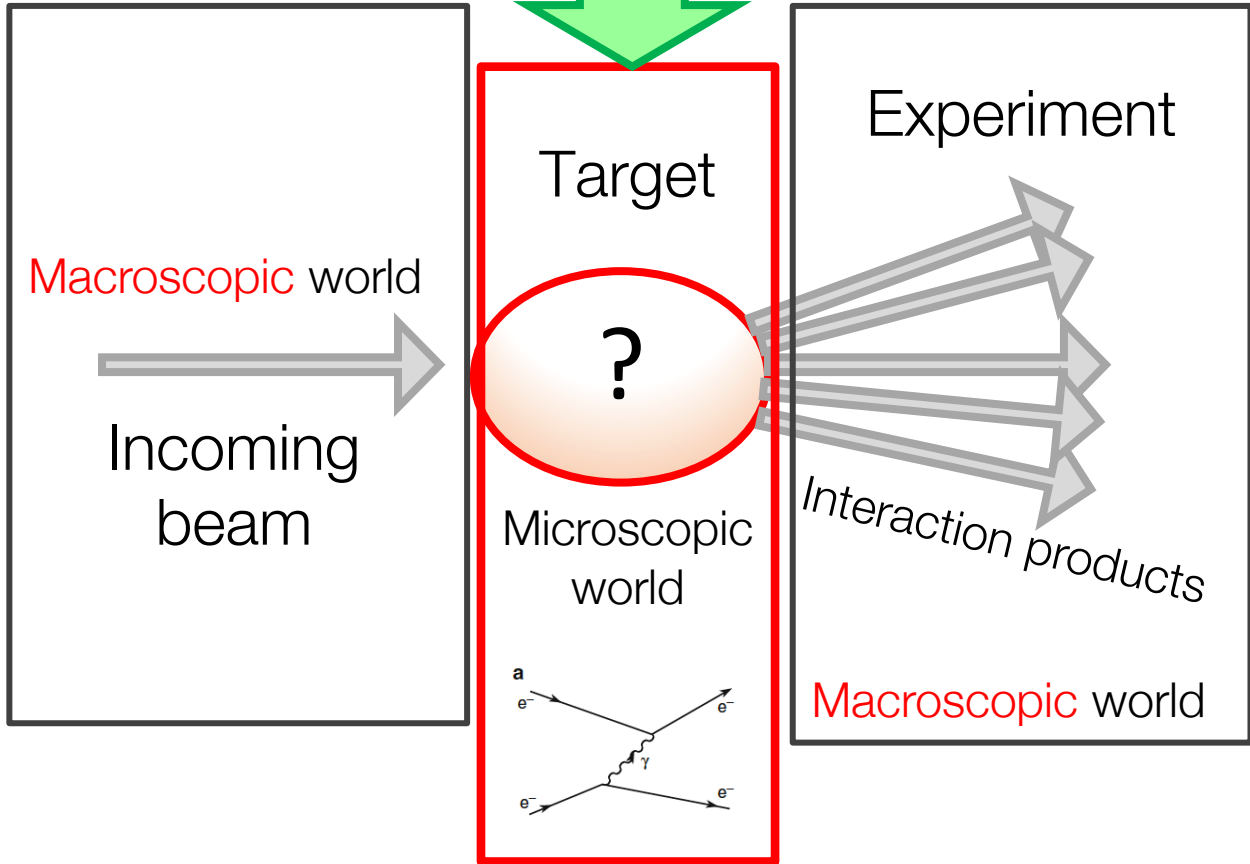

No way to 'see' what is in the microscopic world → can only see the effect of sending a projectile on your target

'Incoming beam' and 'Target' may be not point-like,

it may have a structure, like a proton (or a nucleus)

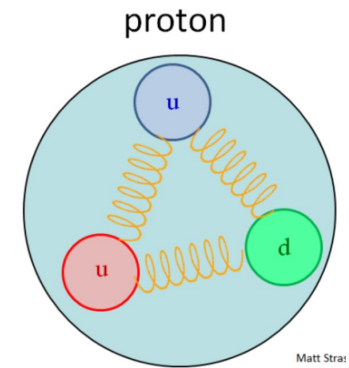

Matt Straz

# Nuclear Sizes → why electron scattering?

Nuclear sizes and shapes → use scattering technique → use a projectile (accelerated or from radioactivity) that hits a target

Protons are extended and complex objects

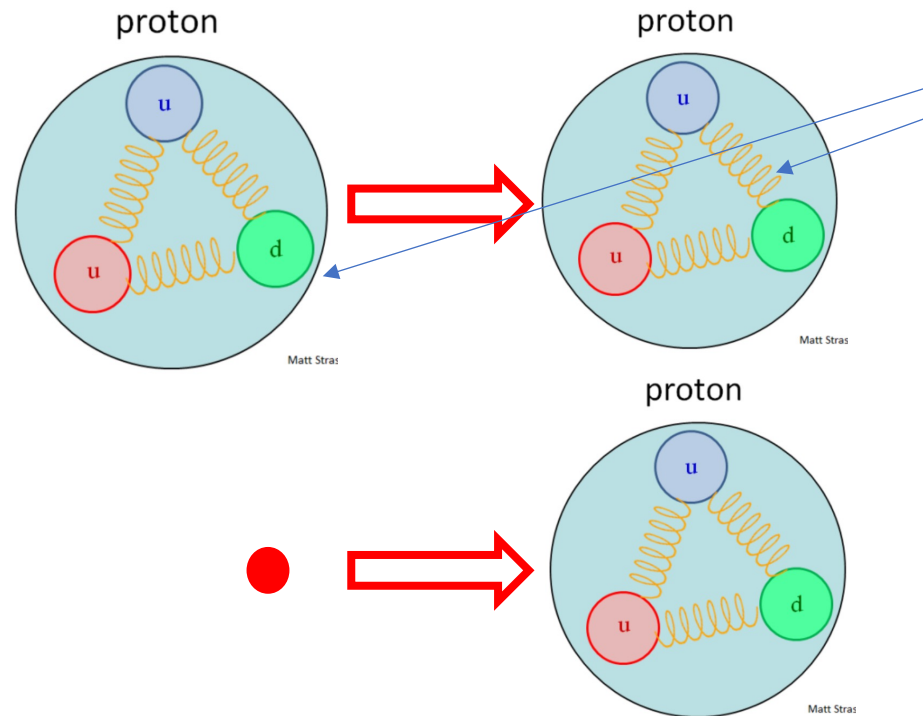

nuclear forces between the projectile and the target are complex and complex to describe

Use electrons! Point-like projectiles!

- *The interactions between an electron and a nucleus, nucleon or quark takes place via the exchange of a virtual photon — this may be very accurately calculated in quantum electrodynamics (QED).*
- *These processes are in fact manifestations of the well known electromagnetic interaction, whose coupling constant  $\alpha \approx 1/137$  is much less than one. This last means that higher order corrections play only a tiny role*



# Preparing electron scattering studies!

In electron scattering experiments one employs highly relativistic particles  $\rightarrow$  use four-vectors in calculations. The zero component of space-time four-vectors is *time*, the zero component of four momentum vectors is *energy*:

$$x = (x_0, x_1, x_2, x_3) = (ct, \mathbf{x}),$$
$$p = (p_0, p_1, p_2, p_3) = (E/c, \mathbf{p}).$$

Three-vectors are '**bold**'. The Lorentz-invariant scalar product of two four-vectors  $a$  and  $b$  is defined by

$$a \cdot b = a_0 b_0 - a_1 b_1 - a_2 b_2 - a_3 b_3 = a_0 b_0 - \mathbf{a} \cdot \mathbf{b}.$$

Let's compute the four-momentum squared  $p^2 = \frac{E^2}{c^2} - \mathbf{p}^2$ .

This squared product is equal to the square of the rest mass  $m^2 c^2$ . In fact it is always possible to find a reference frame in which the particle is at rest  $\rightarrow \mathbf{p} = \mathbf{0}$ , and  $E = mc^2$ . The quantity

$$m = \sqrt{p^2}/c \text{ is called the invariant mass}$$

From the two relations above we obtain  $E^2 - \mathbf{p}^2 c^2 = m^2 c^4$

for electrons  $\sim$  high energy electrons (already at energies of a few MeV)  $E \approx |\mathbf{p}| c$  if  $E \gg mc^2$ .



# The 'low energy' case

$$\begin{aligned} E^2 &= m^2 + p^2 \quad (c = 1) \\ E &= m \cdot \sqrt{1 + \frac{p^2}{m^2}} \\ &\approx m \cdot \left( 1 + \frac{1}{2} \frac{p^2}{m^2} + \dots \right) \approx m + \frac{p^2}{2m} \\ &\approx \frac{p^2}{2m} \end{aligned}$$

To answer, let us consider  $v \ll c$ .

Then  $\vec{p} \approx \vec{v} \frac{E_0}{c^2} = m\vec{v}$

and  $E = E_0 + T = \sqrt{p^2 c^2 + m^2 c^4}$

$$\begin{aligned} &= mc^2 \left( 1 + \frac{p^2 c^2}{m^2 c^4} \right)^{1/2} \\ &\approx mc^2 \left( 1 + \frac{1}{2} \frac{p^2 c^2}{m^2 c^4} + \dots \right) \\ &= mc^2 + \frac{p^2}{2m} + \dots \end{aligned}$$



# (Geometric) Cross Sections – 1 (Povh...)

Structure of the matter is studied with scattering experiments. Energetic projectiles  $\rightarrow$  small equivalent wave length

$$\lambda = \hbar/p$$

## Ideal Simplified Experiment:

Beam particles **a** bombard scattering centres **b**.

- reaction occurred when **a** hits **b**.
- The beam particle **a** disappears after the interaction

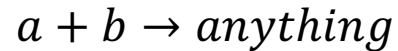

Particle beam **a** coming from left with density  $n_a$  and velocity  $v_a$ . The corresponding flux is

$$\phi_a = n_a \times v_a$$

Target with  $N_b$  scattering centres **b** and particle density  $n_b$

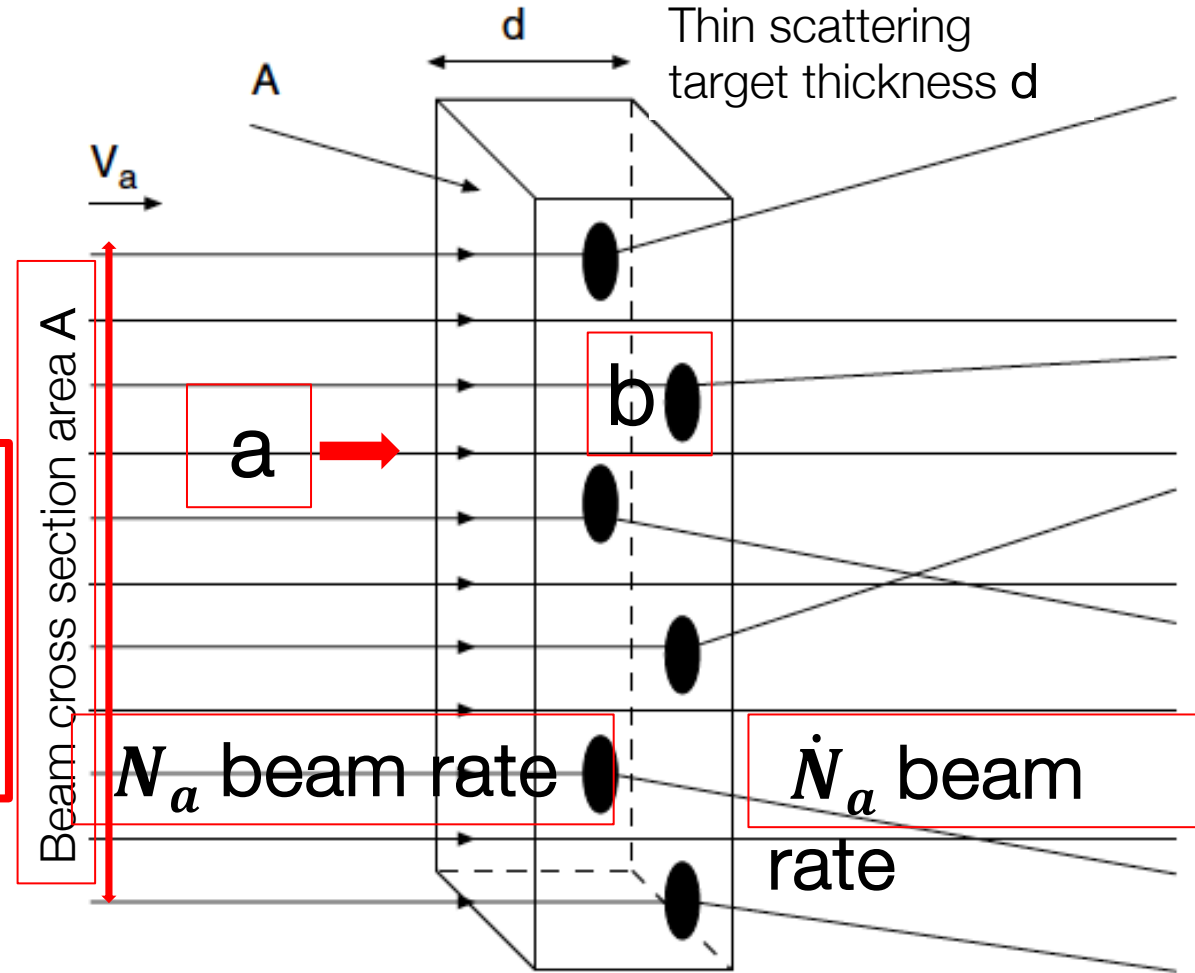

$$N_b = A d n_b$$

$$= (\text{density} \times \text{Volume})_{\text{target}}$$





# (Geometric) Cross Sections - 2 (Povh...)

## Ideal Simplified Experiment:

After the interaction beam particles disappear (we do not distinguish different final topologies, we sum elastic + inelastic cross sections). Reaction rate is

$$\dot{N} = N_a - \dot{N}_a$$

Particle beam **a** coming from left with density  $n_a$  and velocity  $v_a$ . The corresponding flux is

$$\phi_a = n_a \times v_a = \frac{N_a}{A} (\text{area} \times \text{time})^{-1}$$

Target with  $N_b$  scattering centres **b** and particle density  $n_b$ . Target particles within the beam area  $A$  are

$$N_b = A \times d \times n_b$$

→ the reaction rate  $\dot{N}$  is

$$\dot{N} = \phi_a \times N_b \times \sigma_b$$

$$\sigma_b = \frac{\dot{N}}{\phi_a \times N_b}$$

*number of reactions per unit time*

*beam particles per unit time per unit area × scattering centres*

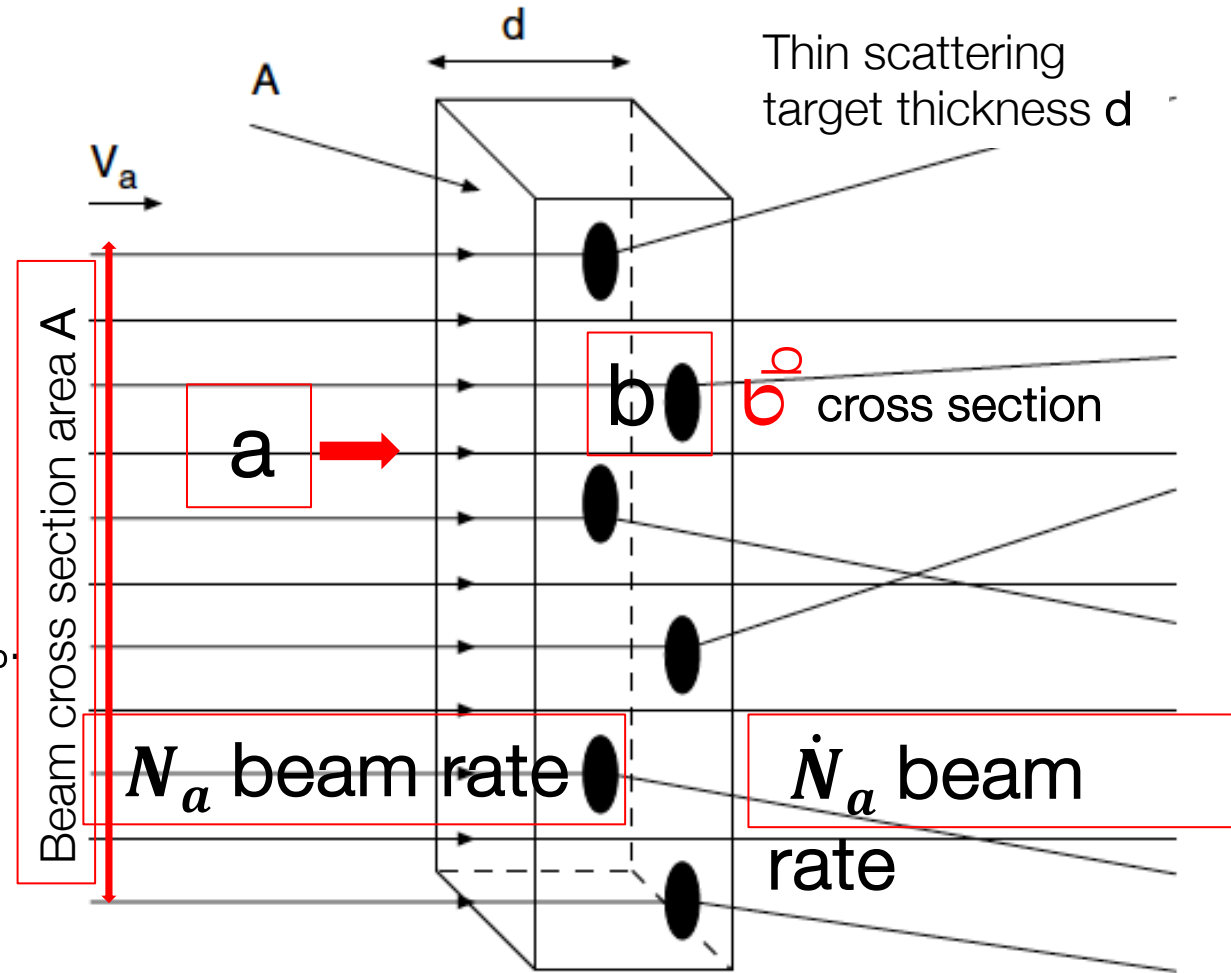

Limitations: HP, scattering centres do not overlap + only one scattering



# (Geometric) Cross Sections - 3 (Povh...)

If beam is not uniform

$$\sigma_b = \frac{\dot{N}}{\phi_a \times N_b} = \frac{\text{number or reactions per unit time}}{(\text{beam particles per unit time} \times \text{scattering centres}) \text{ per unit area}}$$

In the expression

$$\sigma_b = \frac{\dot{N} \text{ Physics!}}{\phi_a \times N_b \text{ Experiment}}$$

$(\phi_a \times N_b) =$  Luminosity,  $\mathcal{L}$  in this case

- Energy dependence
- Particle types..

$$\dot{N} = \mathcal{L} \times \sigma_b$$

The total cross section  $\sigma_{tot}$  is as the sum of elastic and inelastic cross section

$$\sigma_{tot} = \sigma_{el} + \sigma_{inel}$$

and has dimensions of area. a common unit to define cross sections is the **barn**

$$\sigma_{pp}(10 \text{ GeV}) \sim 40 \text{ mb}, \sigma_{vp}(10 \text{ GeV}) \sim 70 \text{ fb} \text{ (ratio is } \rightarrow 10^{-12})$$

Unit	Symbol	m <sup>2</sup>	cm <sup>2</sup>
megabarn	Mb	10 <sup>-22</sup>	10 <sup>-18</sup>
kilobarn	kb	10 <sup>-25</sup>	10 <sup>-21</sup>
<b>barn</b>	b	10 <sup>-28</sup>	10 <sup>-24</sup>
millibarn	mb	10 <sup>-31</sup>	10 <sup>-27</sup>
microbarn	μb	10 <sup>-34</sup>	10 <sup>-30</sup>
nanobarn	nb	10 <sup>-37</sup>	10 <sup>-33</sup>
picobarn	pb	10 <sup>-40</sup>	10 <sup>-36</sup>
femtobarn	fb	10 <sup>-43</sup>	10 <sup>-39</sup>
attobarn	ab	10 <sup>-46</sup>	10 <sup>-42</sup>
zeptobarn	zb	10 <sup>-49</sup>	10 <sup>-45</sup>
yoctobarn	yb	10 <sup>-52</sup>	10 <sup>-48</sup>



# The Luminosity (~ Technology, not Physics)

$$\mathcal{L} = \phi_a \cdot N_b$$

*Beam on a target*

Luminosity : [(area x time)<sup>-1</sup>]. From  $\phi_a = n_a \times v_a$  and  $N_b = n_b \cdot d \cdot A$  we have

$$\mathcal{L} = \phi_a \cdot N_b = \dot{N}_a \cdot n_b \cdot d = n_a \cdot v_a \cdot N_b$$

**Luminosity** → defined as one of two products below

1. number of incoming beam particles per unit time  $N_a$ , the target particle density in the scattering material  $n_b$ , and the target's thickness  $d$ ;
2. beam particle density  $n_a$ , their velocity  $v_a$  and the number of target particles  $N_b$  exposed to the beam.

$j$  packets with  $N_a$  or  $N_b$  particles, a ring of circumference  $U$ . velocity  $v \sim c$  in opposite directions and cross at an interaction point

$$\mathcal{L} = \frac{N_a \cdot N_b \cdot j \cdot v / U}{A}$$

*two beams in a storage ring.*

The luminosity is then:

$A$  = beam cross-section at the collision point. For a Gaussian distribution of the beams ( $\sigma_x$  and  $\sigma_y$  respectively),

$$A = 4\pi\sigma_x\sigma_y.$$

... and have to be well aligned:  
LHC ~27Km circumference!

→ beams must be focused at the interaction point into the smallest possible area possible. Typical beam diameters are of the order of tenths of millimetres or less.



# Differential and Doubly-Differential Cross Sections

Real life: In all experiments only a fraction of all reactions are measured or accessible because of limited **acceptance** of the experimental set-up.

Detector of area  $A_D$  at a distance  $r$  and at an angle  $\theta$ , it covers a solid angle equal to  $\Delta\Omega = A_D/r^2$ .

The reaction rate (assumed to depend on the energy of the incoming beam and on the angle  $\theta$ ) will be:

$$N(E, \theta, \Delta\Omega) = \mathcal{L} \frac{d\sigma(E, \vartheta)}{d\Omega} \Delta\Omega$$

If the energy & direction of the products is measured then the doubly differential cross section is also measured  $d^2\sigma(E, E', \theta)/d\Omega dE'$ . The total cross section, in this case, will be the integral over the solid angle and over the scattering energies

$$\sigma_{tot}(E) = \int_{E_{min}}^{E_{max}} \int_{\theta_{min}}^{\theta_{max}} \frac{d^2\sigma(E, E', \theta)}{d\Omega dE'} d\Omega dE'$$

Only a part of  $\sigma_{tot}(E)$  measured due to acceptance

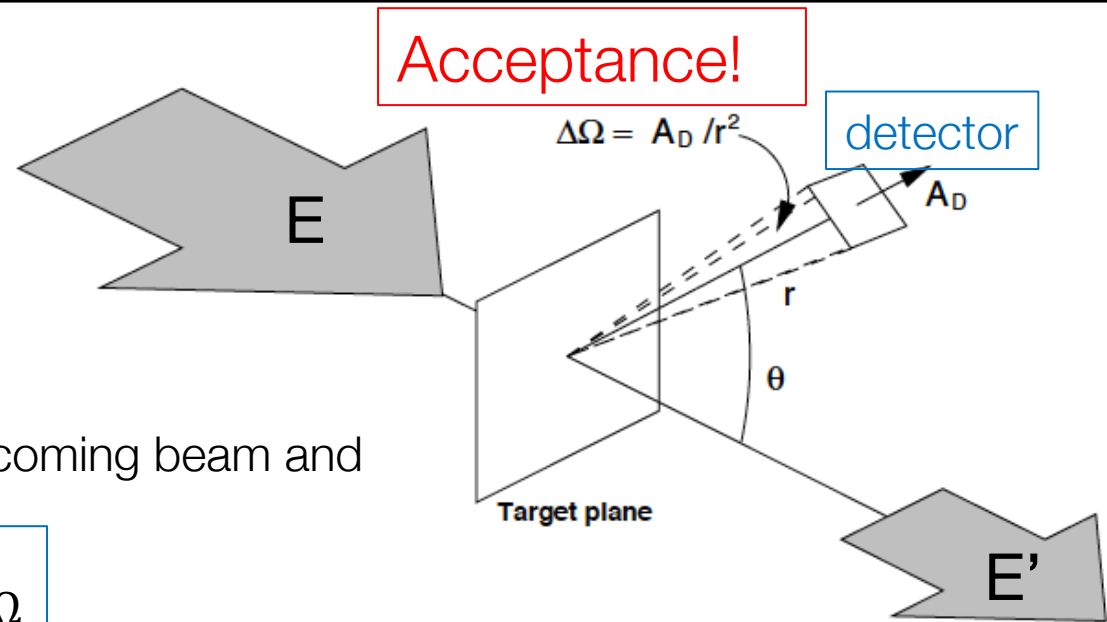



# Cross Sections from Theory: The Fermi Golden Rule

Scattering processes  $\rightarrow$  cross sections. Can we compute it with theory?

*Particle Physics: based on the study of cross-sections and decays  $\rightarrow$  interaction rates & decay rates. These rates can be derived using the Fermi's Golden Rule.*

Reaction rate  $W$  from an initial  $\psi_i$  to a final state  $\psi_f$  is given by

$$W = 2\pi \cdot |M_{fi}|^2 \rho(E)$$

where  $M_{fi}$  ('Transition Matrix element') is

$$M_{fi} = \langle \psi_f | \mathcal{H}_{int} | \Psi_i \rangle + \text{higher orders}$$

And  $\rho(E)$  is the 'density of states' (: "in how many possible ways can you create the final state you are studying?")

- $M_{fi}$  contains Physics
- $\rho(E)$  contains kinematics

If interaction rate is  $\sim$ low  $\rightarrow$  *perturbation expansion*

$$M_{fi} = \langle \psi_f | \mathcal{H}_{int} | \Psi_i \rangle + \dots$$



# The Golden Rule: the Density of States

Cross section also depends on the number of final states available to the reaction.

According to the Heisenberg uncertainty principle each particle occupies a volume  $h^3 = (2\pi\hbar)^3$  in the 6-dim position-momentum space  $\Delta_x \cdot \Delta_y \cdot \Delta_z \cdot \Delta p_x \cdot \Delta p_y \cdot \Delta p_z$

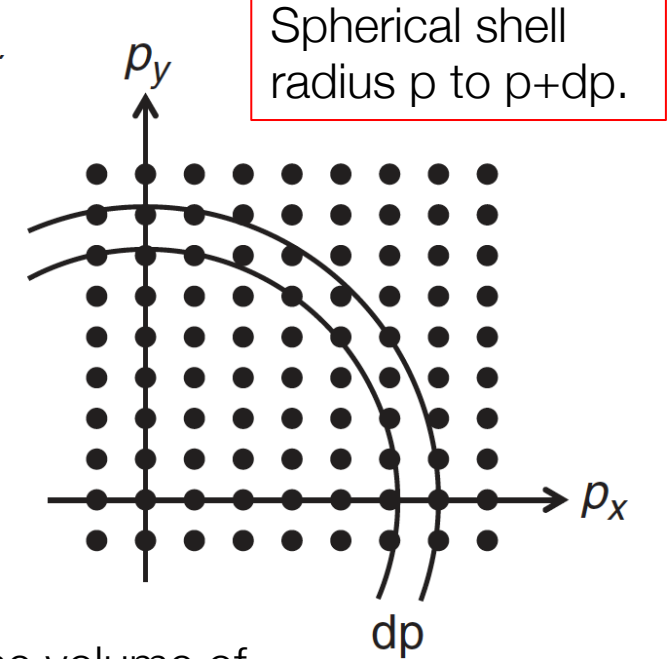
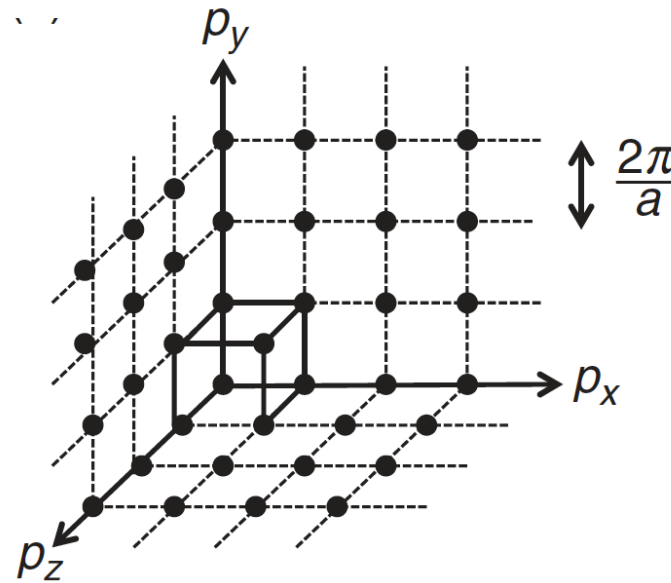

Consider a particle scattered into a volume  $V$  in a momentum interval  $\mathbf{p}'$ ,  $\mathbf{p}'+\delta\mathbf{p}'$ . The volume of this spherical shell is  $4\pi p'^2 \delta p'$  and the total number of final states is

$$dn(p') = \frac{V 4\pi p'^2 \delta p'}{(2\pi\hbar)^3 \text{ Volume occupied by 1 particle}}$$

the density of final states  $\rho(E')$  is ( $dE' = v' dp'$ )

$$\rho(E') = \frac{dn}{dE'} = \frac{dn dp'}{dp' dE'} = \frac{V 4\pi p'^2}{v' (2\pi\hbar)^3}$$

(you may consider  $V = 1$ )

$$E = m + \sqrt{p^2 + m^2}$$

$$dE = dp p/E$$

$$E = mc^2 \gamma, p = m v \gamma \rightarrow p/E = v$$

$v$  = velocity of scattered particle



# The Fermi Golden Rule - continued

According to the Fermi second golden rule (not derived here): *reaction rate*  $W$  (per beam particle and per target particle), transition matrix and density of final states

$$W = 2\pi \cdot |M_{fi}|^2 \rho(E)$$

Few slides ago  $\sigma_b = \frac{\dot{N}}{\phi_a \times N_b}$  ( $\phi_a = n_a \times v_a$ )  $\rightarrow W = \frac{N(E)}{N_b N_a} = \frac{\sigma_b v_a}{V}$  where  $V$  = is the spatial volume occupied by beam particles

$$\sigma = \frac{2\pi}{\hbar v_a} \overset{\text{Theory}}{|M_{fi}|^2} \rho(E') V$$

Transition matrix  $M_{fi}$   
Reaction rate  $W$   
Cross section  $\sigma$

- If interaction potential is known or calculable  $\rightarrow$  compute the cross section
- if  $M_{fi}$  is not known one can measure  $\sigma$  and derive  $M_{fi}$  from it.

The Golden Rule applies both to scattering and decay processes. In the second case the lifetime of the process will be

$$\tau = \frac{1}{W}$$

- if the lifetime is (can be) measured then  $M_{fi}$  can be derived.
- If  $\tau$  cannot be measured then the uncertainty principle can be used and we can take  $\Delta E = \hbar/\tau$



# Feynman Diagrams (Povh...)

Feynman diagrams → graphic representation of scattering → symbols into the matrix element.

- Works for
  - QED and
  - weak interactions also for
  - strong interactions (quantum chromodynamics, QCD).

Drawing rules:

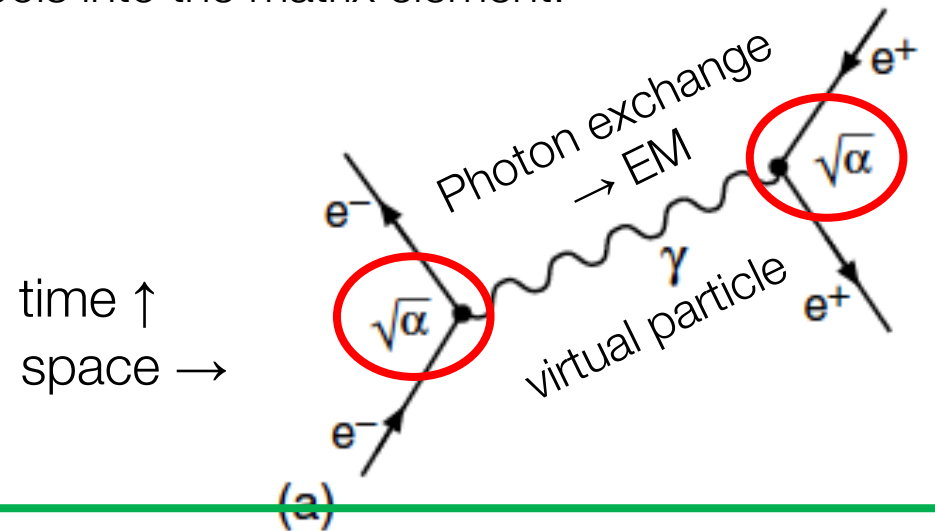

- The time axis runs  $\uparrow$  and the space axis  $\rightarrow$ .
- The straight lines correspond to the wave functions of the initial and final fermions.
- Antiparticles → arrows pointing backwards in time; by wavy lines;
- photons
- heavy vector bosons by dashed lines;
- and gluons by corkscrew-like lines.

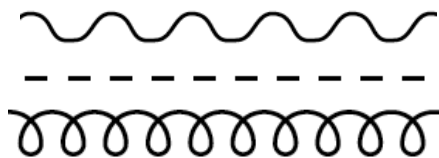

*Uncertainty principle* → virtual particles do not satisfy the energy-momentum relation  $E^2 = p^2c^2 + m^2c^4$

- 1] the exchanged particle has a mass different from that of a free (real) particle, or
- 2] that energy conservation is violated for a brief period of time.





# Feynman Diagrams for Em, Weak, Strong Interactions

Points at which three or more particles meet are called vertices.

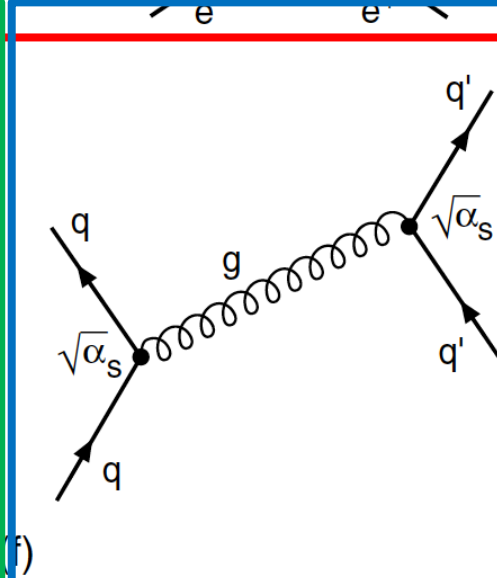
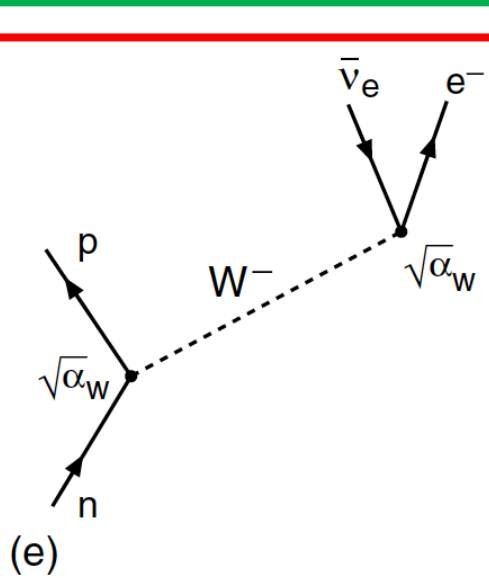
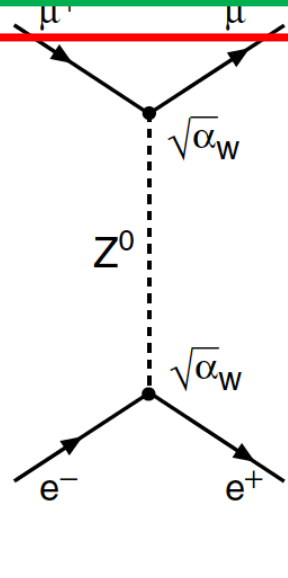
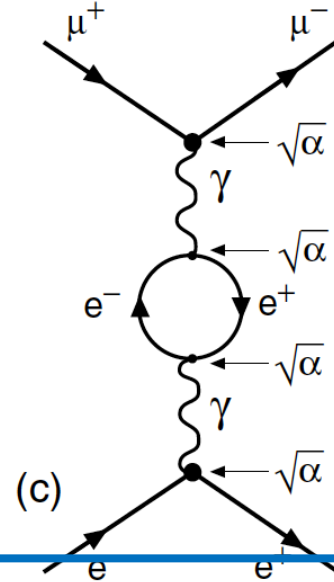
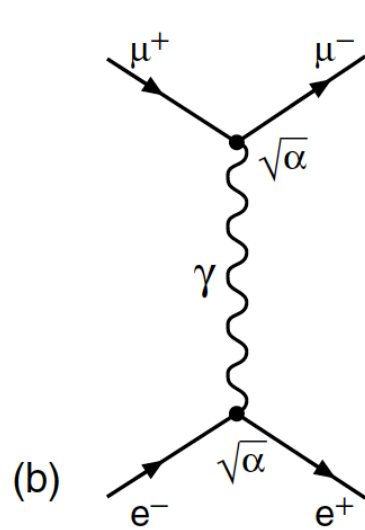
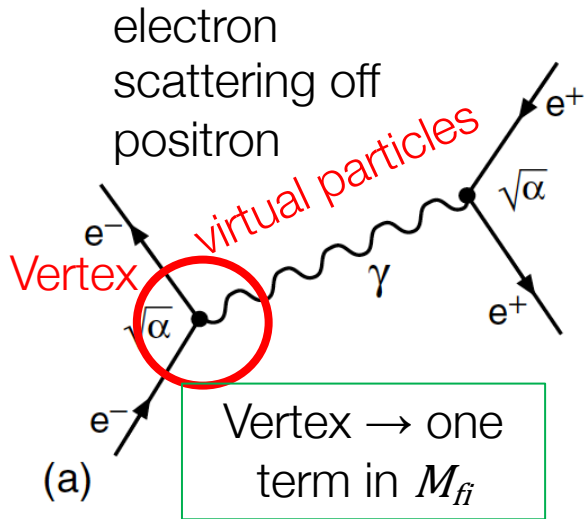

Feynman diagrams for the electromagnetic (a, b, c), weak (d, e) and strong interactions (f).

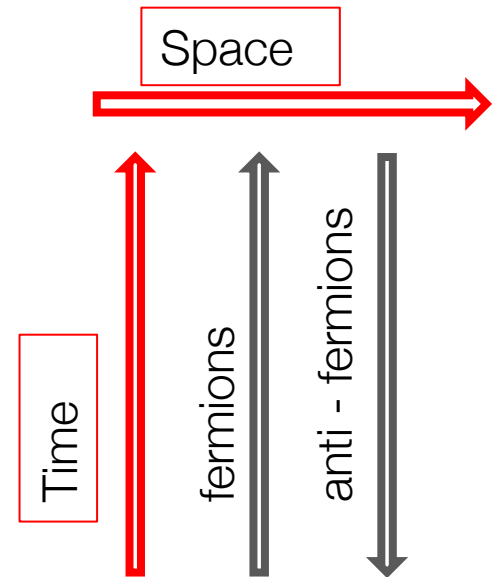

In QED, as in other quantum field theories, we can use the little pictures invented by my colleague Richard Feynman, which are supposed to give the illusion of understanding what is going on in quantum field theory.

M. Gell-Mann [Ge80]



# Feynman Diagrams – EM

$$\sigma = \frac{2\pi}{\hbar v_a} \hbar |M_{fi}|^2 \rho(E')V$$

$$\alpha = \frac{e^2}{\hbar c}$$

$$\sqrt{\alpha} \propto e$$

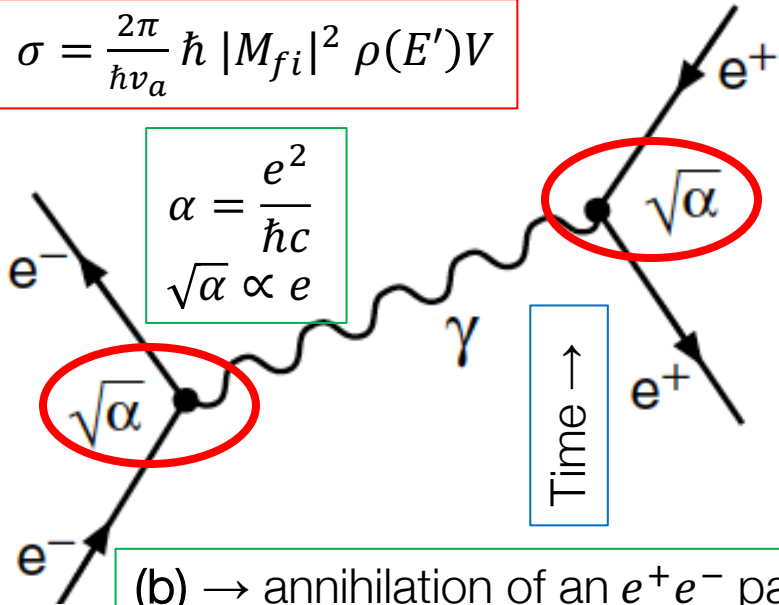

**One vertex  $\rightarrow$  one term in the transition matrix** ( structure and strength of the interaction).

$\leftarrow$  the exchanged photon couples to the charge of the electron at the left vertex and to that of the positron at the right vertex. **For each vertex the transition amplitude contains a factor which is proportional to  $e \rightarrow \sqrt{\alpha}$ .**

(b)  $\rightarrow$  annihilation of an  $e^+e^-$  pair. A photon is created as an intermediate state which then decays into a  $\mu^+\mu^-$  pair.  
 (c) same process with one additional diagram contributing to the same final state  $\rightarrow$  **higher-order diagrams**. The transition matrix is the sum of all diagrams  $\rightarrow$  same final state.

More vertices implies higher powers of  $\alpha$ .

Diagram (b) is  $\propto \alpha$

Diagram (c) is  $\propto \alpha^2$ .

$e^+e^- \rightarrow \mu^+\mu^-$  is given by graph (b) + higher diagrams produce only small corrections to (b).  $\alpha \sim 1/137$

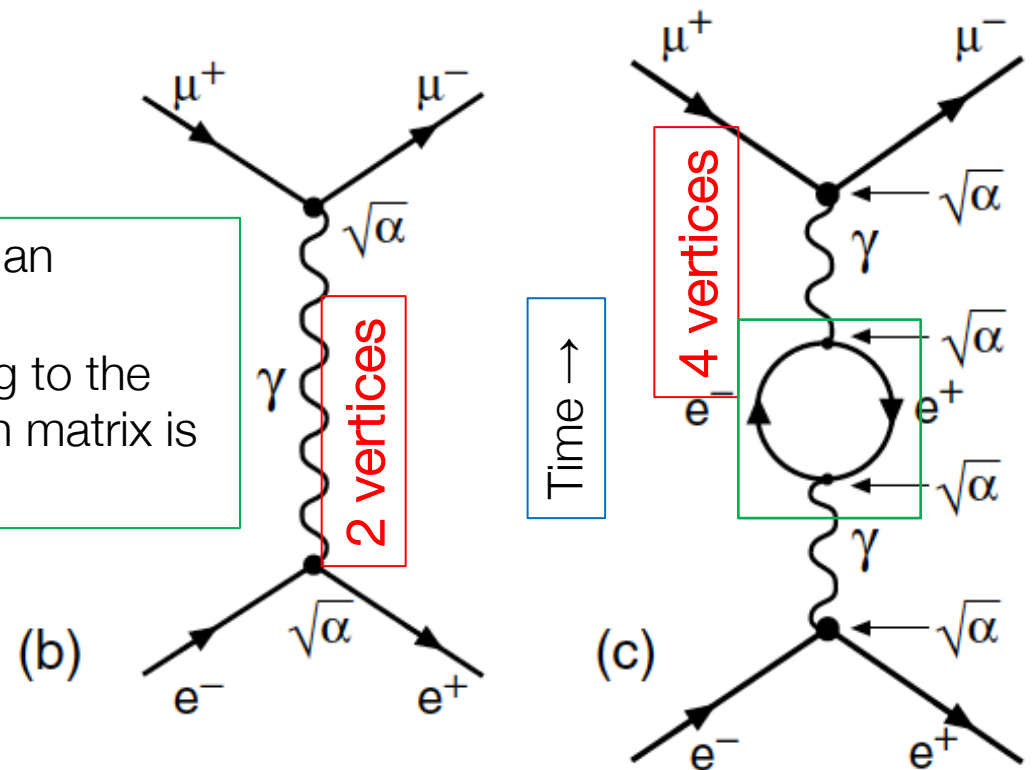



# Feynman Diagrams – EM

Annihilation of an  $e^+e^-$  pair into a  $\mu^+\mu^-$  pair.

=

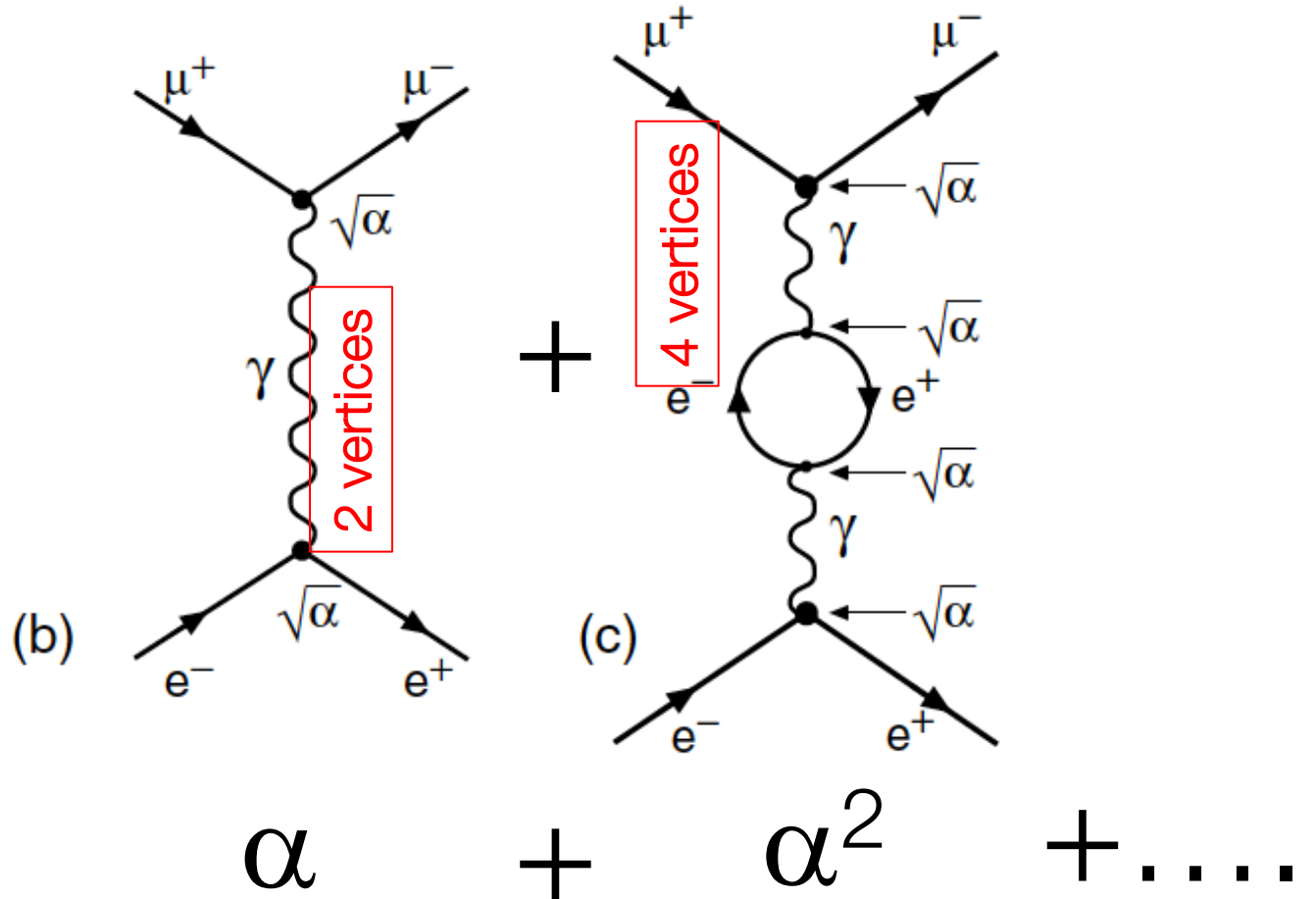

=



# Feynman Diagrams – Weak & Strong

Toni Baroncelli: Introduction to Particle Physics

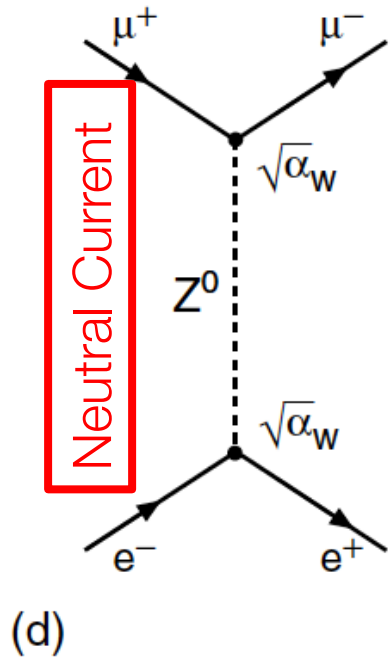
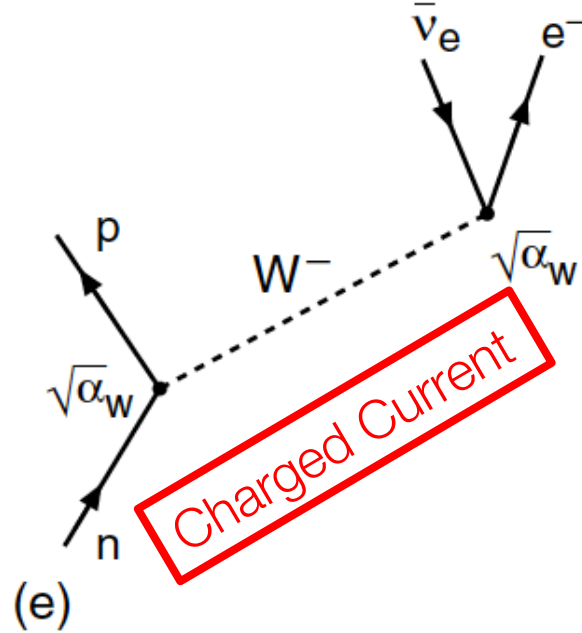

Figure (d) shows electron-positron annihilation followed by muon pair production in a weak interaction: exchange of the neutral, heavy vector boson  $Z^0$  → **weak interaction**



In Figure (e), we see a neutron that transform into a proton via  $\beta^-$ -decay in which it emits a negatively charged heavy vector boson  $W^-$  which then decays into an electron and antineutrino  $\bar{\nu}_e$ . → **weak interaction**

time ↑

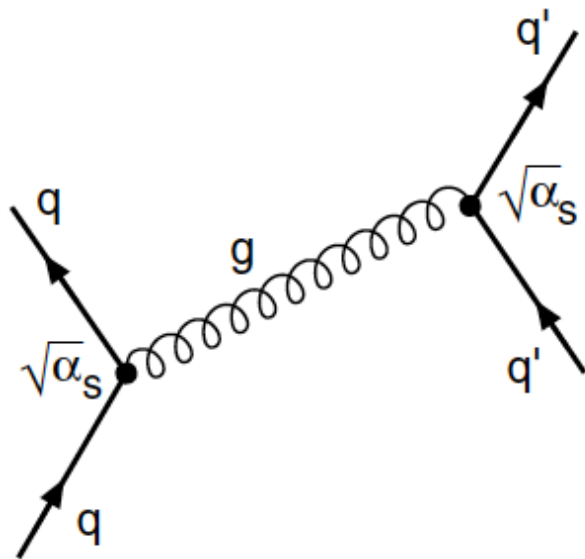

Figure (f) strong interaction process between two quarks  $q$  and  $q'$  which exchange a gluon → **strong interaction**

(f)



# Feynman Diagrams: Weak & Strong Interactions

- In weak interactions, a heavy vector boson is exchanged which couples to the “weak charge”  $g$  and not to the electric charge  $e$ .  $\rightarrow$  weak interaction,  $M_{fi} \propto g^2 \propto \alpha_w$ .
- In strong interactions the gluons which are exchanged between the quarks couple to the “colour charge” of the quarks,  $M_{fi} \propto \sqrt{\alpha_s} \cdot \sqrt{\alpha_s} = \alpha_s$ .

The ‘propagator’

The exchanged particles contribute a **propagator** term to the transition matrix element:

$$\frac{1}{Q^2 + M^2 c^2}$$

$Q^2$  is the four-momentum<sup>2</sup> of the virtual exchanged particle  
 $M$  is the mass of the virtual exchanged particle

Exchanged photon (EM interactions):

$\rightarrow 1/Q^2$  in the amplitude and  $1/Q^4$  in the cross-section.

Exchanged  $W^\pm, Z$  (Weak interaction):

$\rightarrow$  large mass  $\rightarrow$  the cross-section is much smaller than EM interaction

BUT at very high momentum transfers, of the order of the masses of the vector bosons, the two cross-sections become comparable in size.



# Of the Scattering Processes (real life)

Scattering experiments → determine the transition matrix element.

Scattering experiment = beam projectiles particles hit a target (or two beams clashing against each other).

- **Projectiles are or may be extended objects** (low energy particles have a large  $\lambda = \hbar/p$ ; The more energetic projectiles are used the smaller is the equivalent de Broglie wave length  $\lambda = \hbar/p$ , small wave lengths allow the inspection of the inner structure of the matter).
- protons have an **internal structure**, we know they are composite objects (alfa particles even more);

- **electrons**, as far as we know, **are point-like objects**, the interaction between electrons and a nucleus or a quark proceeds via the exchange of a photon;
- **Processes mediated by photons have two advantages:**
  1. The first one is that they are well known since long.
  2. The second positive fact is that these interactions are characterised by a strength (i.e. a coupling constant)  $\alpha=1/137$  which is rather small and allows the perturbation

theory to be applied

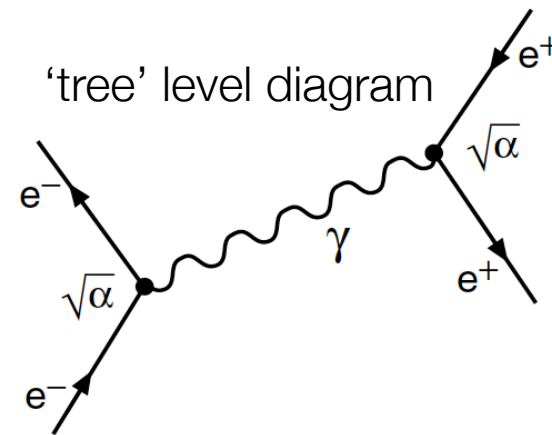

higher level diagram → small contribution to cross section

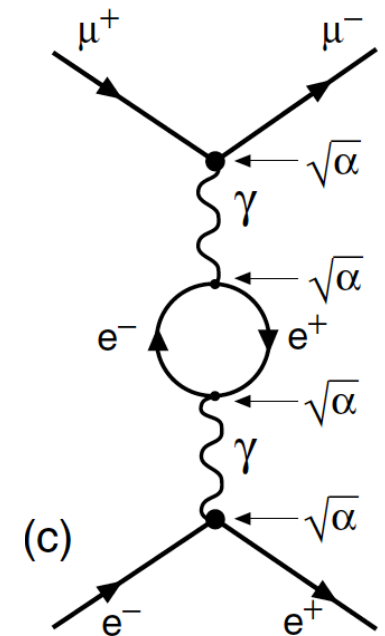



# Electron Nucleus Kinematics

**Elastic Scattering** of an Electron on a Particle at Rest with Mass  $M$   
*(assumed to be a proton)*

→ *electron and particle with mass  $M$  remain unchanged in the final state*

	Initial state	Final state
electron	$E, \mathbf{p}$	$E', \mathbf{p}'$
nucleus	$E_p, \mathbf{P}$	$E_p', \mathbf{P}'$

## 4 – Momenta

The energy conservation implies that  
 and also...

$$p + P = p' + P'$$

$$P' = p + P - p'$$

And, once squared,

$$\cancel{p^2} + 2pP + \cancel{P^2} = \cancel{p'^2} + 2p'P' + \cancel{P'^2}$$

4 momenta  $p^2$  and  $p'^2$  are invariant and equal to  $m_e$

4 momenta  $P^2$  and  $P'^2$  are also invariant and equal to  $M$

$$p^2 = p'^2 = m_e^2 c^2 \quad \text{and} \quad P^2 = P'^2 = M^2 c^2$$

$$p + P = p' + P' \rightarrow p' = p + P - P'$$

$$p \cdot P = p' \cdot (p + P - p') = p'p + p'P - m_e^2 c^2$$

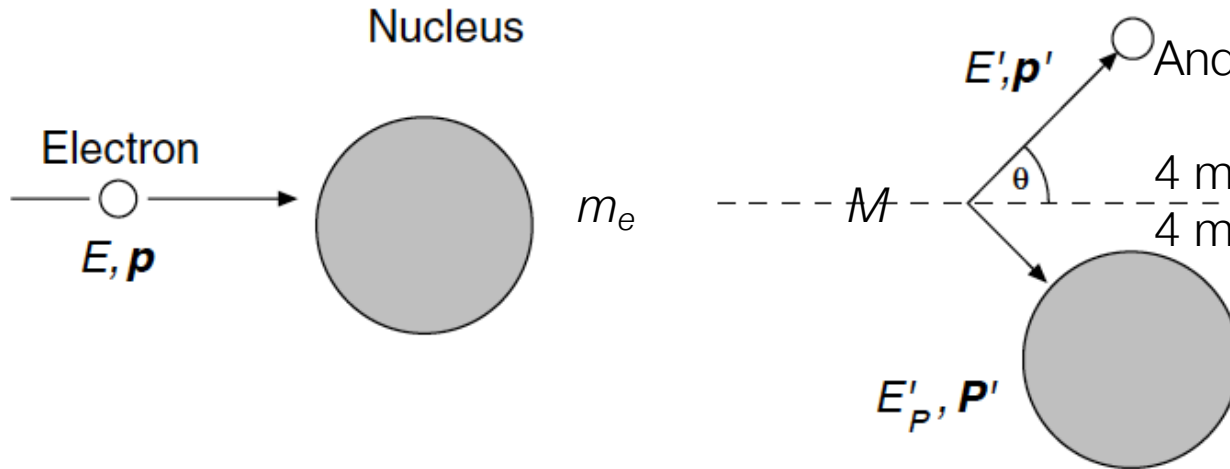

Kinematics of elastic electron – nucleus scattering



# Electron Nucleus Kinematics

$$\mathbf{a} \cdot \mathbf{b} = a_0 b_0 - a_1 b_1 - a_2 b_2 - a_3 b_3 = a_0 b_0 - \mathbf{a} \cdot \mathbf{b}$$

only the electron is detected  $\rightarrow$  use electron kinematics

$$p \cdot P = p' \cdot (p + P - p') = p'p + p'P - m_e^2 c^2$$

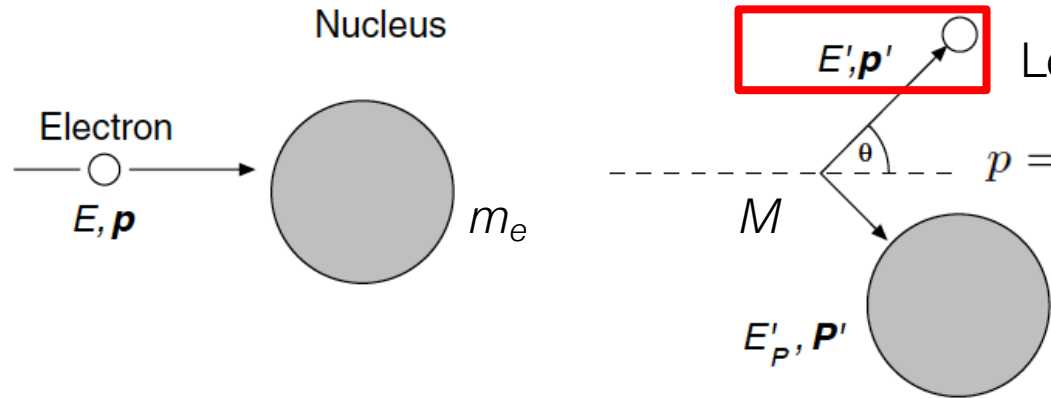

Let's choose the laboratory frame where particle  $P$  is at rest  $\rightarrow$

$$p = (E/c, \mathbf{p}) \quad p' = (E'/c, \mathbf{p}') \quad P = (Mc, \mathbf{0}) \quad P' = (E_P/c, \mathbf{P}')$$

$$E \cdot Mc^2 = E'E - \mathbf{p}\mathbf{p}'c^2 + E'Mc^2 - m_e^2 c^4$$

At high energy we may neglect the electron mass and take  $E \sim |\mathbf{p}| \cdot c \rightarrow E \cdot Mc^2 = E'E \cdot (1 - \cos \theta) + E' \cdot Mc^2$

$\theta$  is the scattering angle between  $\mathbf{p}$  and  $\mathbf{p}'$

$$E' = \frac{E}{1 + E/Mc^2 \cdot (1 - \cos \theta)}$$

In elastic scattering (and only there!) there is a one-to-one correlation between the scattering angle  $\theta$  and the energy of the electron. The recoil energy transferred to the target proton is given by  $E' - E$

$\rightarrow$  if the term  $E/M$  increases  $E'$  decreases  $\rightarrow$  small recoil energy





# Kinematics of Electron Scattering off Nucleus

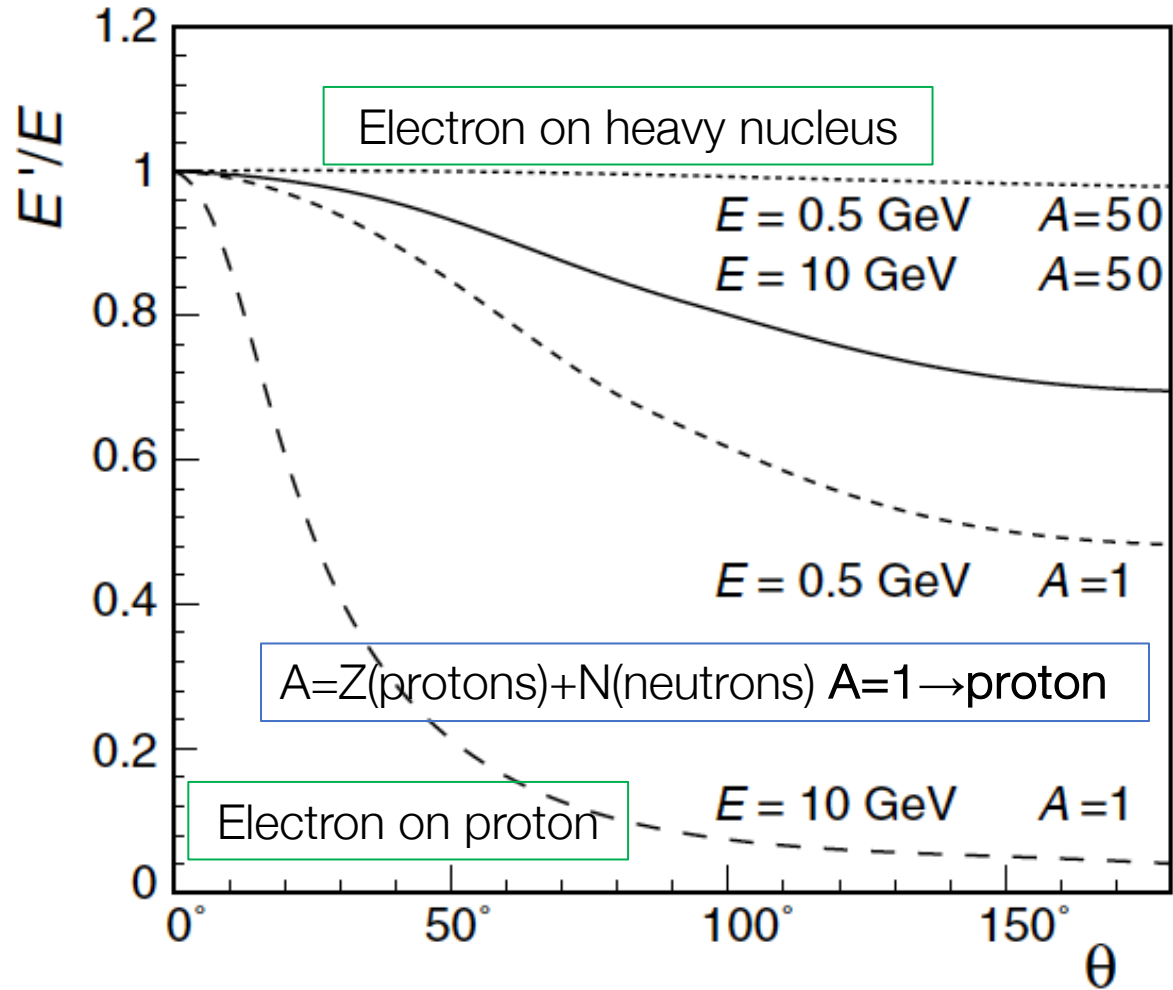

$A = 50 \rightarrow \text{Sn (tin)}$

$$E' = \frac{E}{1 + E/Mc^2 \cdot (1 - \cos \theta)}$$

- Term  $(1 - \cos \theta) E/Mc^2 \rightarrow$  angular dependence
- recoil energy increases with decreasing  $E/Mc^2$

In electron scattering at 0.5 GeV off a nucleus with mass number  $A = 50$  the scattering energy varies by only 2% at most.

At 10 GeV electrons scattering off protons ( $A = 1$ )  $E$  varies between 10 GeV ( $\theta \approx 0^\circ$ ) and 445 MeV ( $\theta = 180^\circ$ ).



# Scattering of electrons on nucleus/proton

Calculation	electron		Target, charge Ze (Z=1 proton)					Expression (we visit these formulas in next slides)
	electron	Electron with spin	Point-like target, infinite Mass	Point-like target with mass M	Point-like proton	Point-like proton with spin	Finite size proton with spin	
Rutherford	✓		✓					$\left(\frac{d\sigma}{d\Omega}\right)_R = \frac{Z^2 e^4}{4E_0^2 (\sin \theta/2)^4}$
Mott		✓		✓				$\left(\frac{d\sigma}{d\Omega}\right)_M = \left(\frac{d\sigma}{d\Omega}\right)_R \cdot (\cos \frac{\theta}{2})^2$
$\sigma_{NS}$		✓			✓			$\left(\frac{d\sigma}{d\Omega}\right)_{NS} = \left(\frac{d\sigma}{d\Omega}\right)_M \cdot 1 / \left(1 - \frac{2E_0}{M} \sin \theta/2^2\right)$
$\sigma$		✓				✓		$\left(\frac{d\sigma}{d\Omega}\right) = \left(\frac{d\sigma}{d\Omega}\right)_M \cdot \left(1 + \frac{q^2}{2M^2} \tan \theta/2^2\right)$
Rosenbluth		✓					✓	$\left(\frac{d\sigma}{d\Omega}\right) = \left(\frac{d\sigma}{d\Omega}\right)_M \cdot \left[ \frac{G_E^2(Q^2) + \tau \cdot G_M^2(Q^2)}{1 + \tau} + 2\tau G_M^2(Q^2) \tan \theta/2^2 \right]$

Account for, electron spin, target spin, charge distribution, magnetic moment

Expression  
(we visit these formulas in next slides)

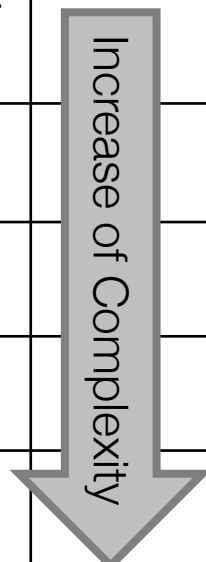



# Rutherford scattering – Classical Calculation

Is the target a point-like object?  
If 'not', how to probe its internal structure?

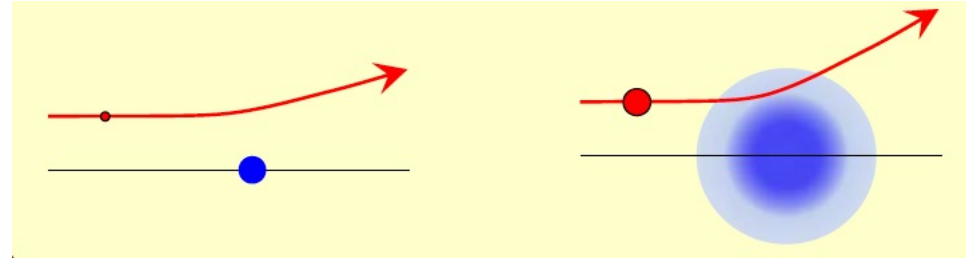

Incoming charged particle



$db$

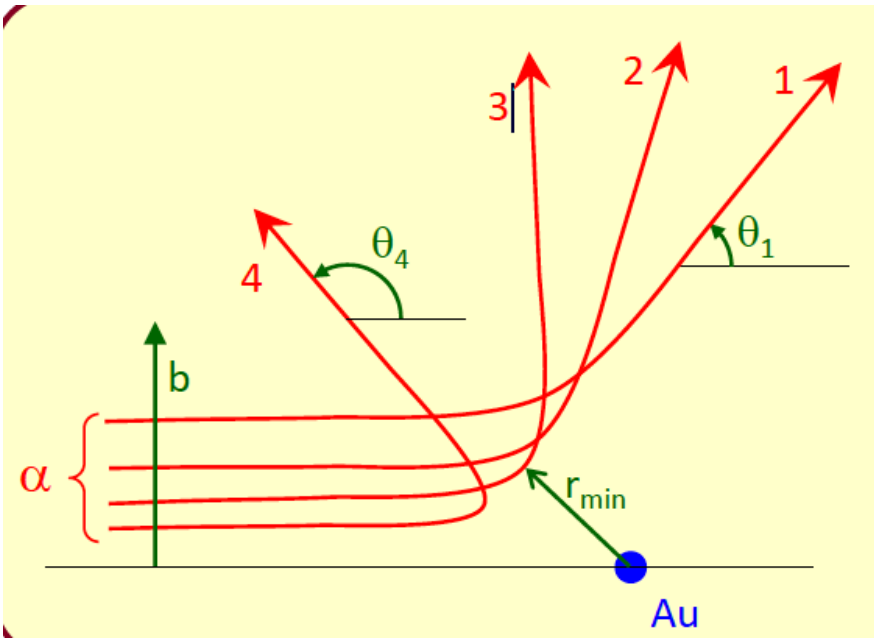
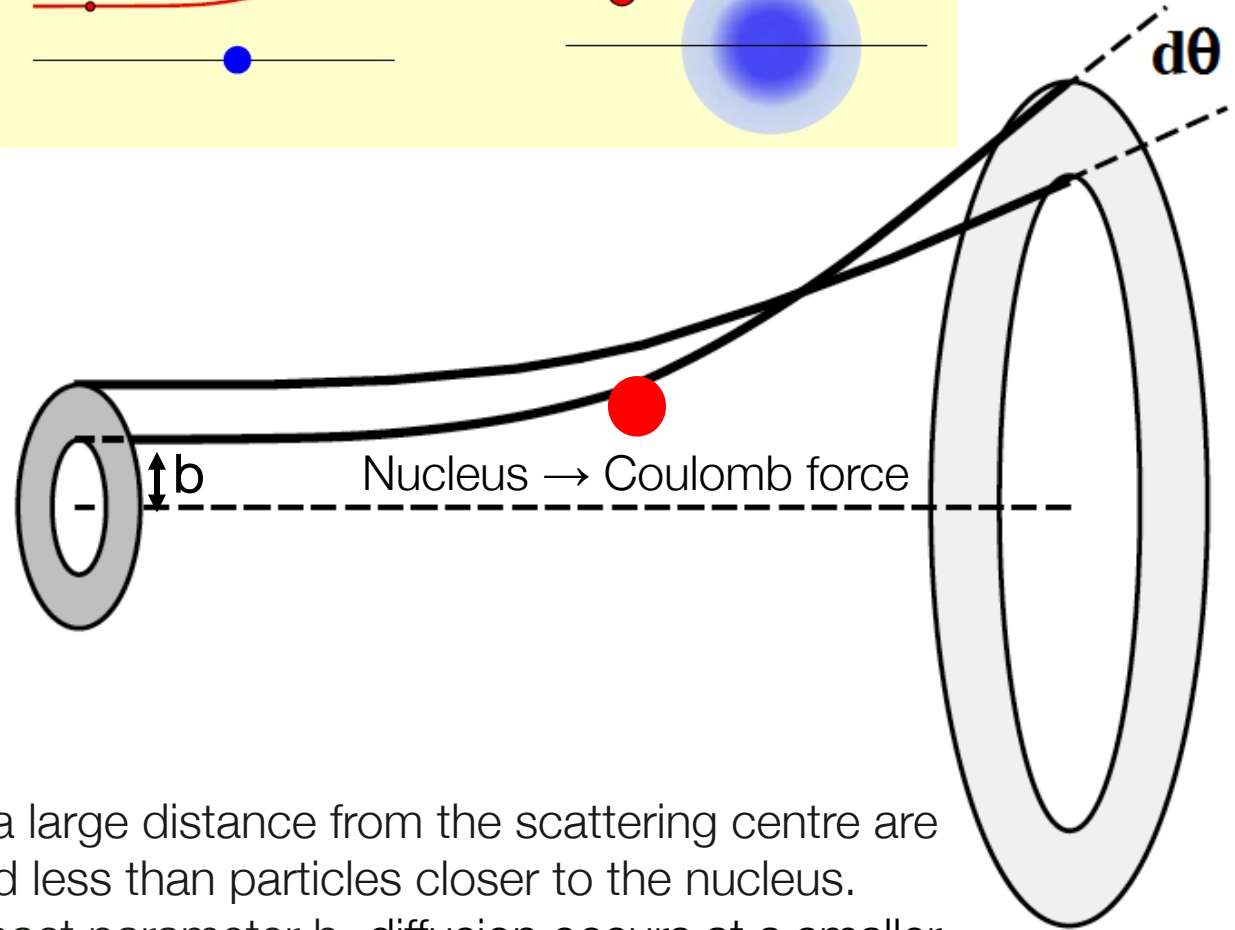

Particles at a large distance from the scattering centre are deflected less than particles closer to the nucleus.  
→ larger impact parameter  $b$ , diffusion occurs at a smaller angle . A negative  $d\theta$  corresponds to a positive  $db$



# Rutherford scattering – Classical Calculation

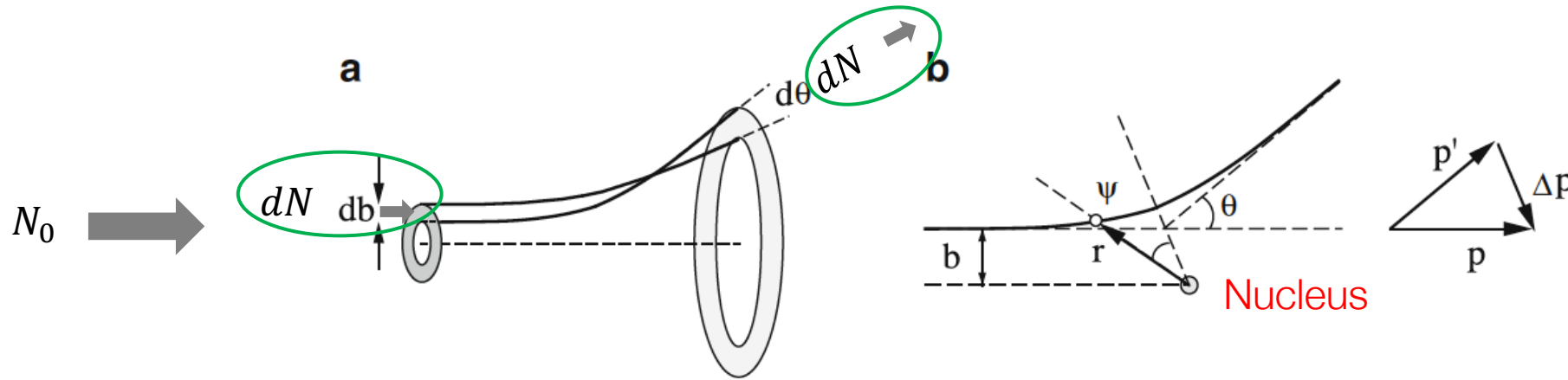

- Charged particles arrive on the ring ( $2\pi b db$ )
- Are elastic scattered by  $\sim$  the Coulomb potential created by a heavy nucleus
- In the angular range  $[\theta, \theta - \delta\theta]$

**Compute this!**

**You measure this!**

→ relation between the impact parameter  $b$  and the deflection angle in the Coulomb elastic scattering.

The number of incident particles elastically scattered per time unit in the interval  $(\theta, \theta - \delta\theta)$  is

$$dN = N_0 2\pi b db = N_0 d\sigma \rightarrow d\sigma = 2\pi b db$$

$d\sigma(\theta)$  = cross section for scattering  $(\theta \rightarrow \theta - \delta\theta)$

- $N_0$  is the number of incident particles per area and time units (*flux*)
- $d\sigma = 2\pi b db$  is the surface of the ring hit by the incident particles in the angular range  $(\theta, \theta - \delta\theta)$ .
- $dN$  is number of particles arriving at  $b$  and scattered at  $\theta$



# Rutherford Scattering - continued

Elastic differential cross-section:

$$d\sigma(\theta) = \frac{d\sigma}{d\Omega}(\theta) d\Omega = \frac{d\sigma}{d\Omega} \boxed{2\pi \sin(\theta)} d\theta$$

Integral over  $2\pi$  in  $\phi$

$$\sigma_{tot}^{el} = \int \frac{d\sigma}{d\Omega}(\theta) d\Omega = 2\pi \int_0^\pi \frac{d\sigma}{d\Omega}(\theta) \sin(\theta) d\theta$$

*Total cross-section: size of the “transverse” area of the diffusion centre*

Scattering of few MeV  $\alpha$  particles ( $^4\text{He}$  nuclei,  $2p$ ,  $\rightarrow z=2$ ) against gold ( $Z = 79$ ) nuclei. The Coulomb potential nucleus (charge  $Z$ ) +  $\alpha$  particle (charge  $z$ ) is

$$V(r) = zZe^2/r$$

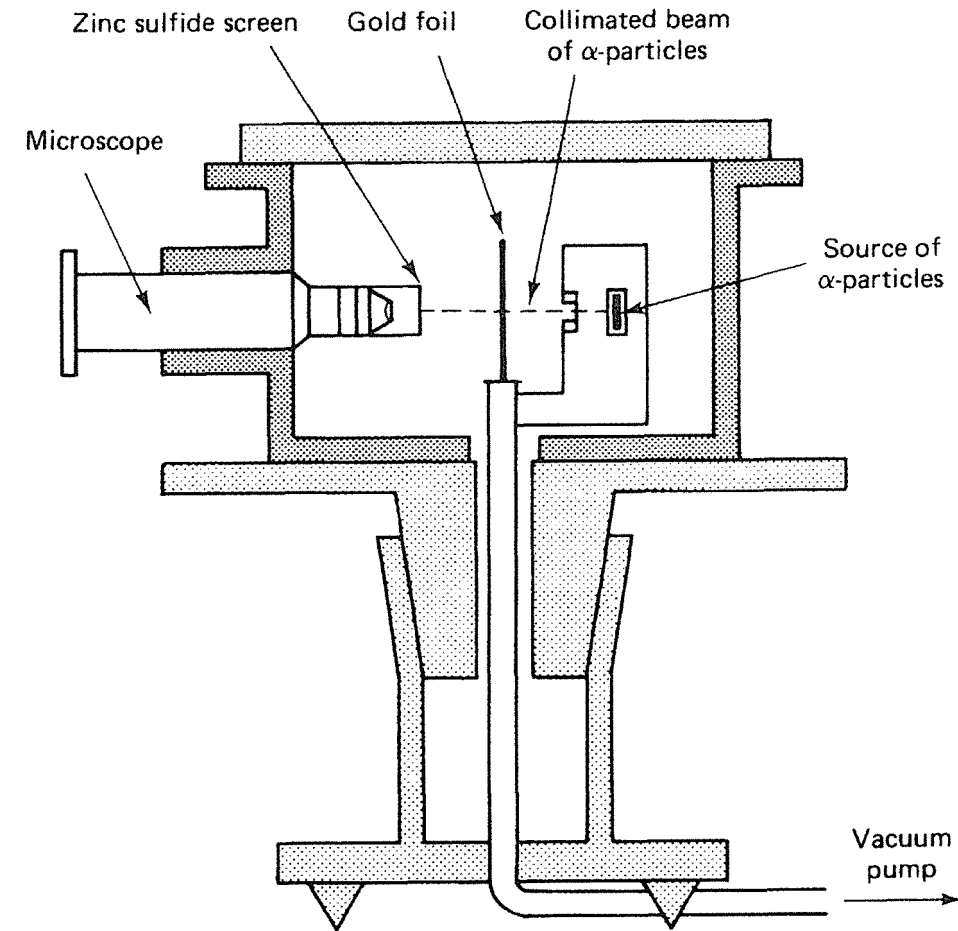

**Fig. 1.1** Schematic diagram of the apparatus used in the Rutherford scattering experiment. Alpha particles scattered by the gold foil strike a fluorescent screen, giving off a flash of light, which is observed visually through a microscope.



# Rutherford scattering - continued

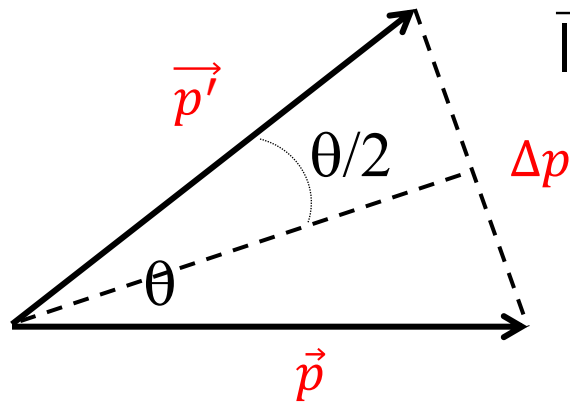

$$|\vec{p}'| = |\vec{p}|; \Delta p = |\vec{p}' - \vec{p}| = 2 p \sin\left(\frac{\theta}{2}\right)$$

After a bit of mathematics ... Look at Lecture Notes!!

$p$  = momentum of  $\alpha$  particle,

$$\tan\left(\frac{\theta}{2}\right) = \frac{zZe^2 m}{p^2 b} \rightarrow b = \frac{zZe^2 \cot(\theta/2)}{p^2} \frac{zZe^2 m}{p^2 \tan(\theta/2)}$$

And using

- $d(\cot x) = -(\sin x)^2 dx$
- Introduce solid angle  $d\Omega = 2\pi \sin\theta d\theta$
- and use  $\sin\theta = 2 \sin\left(\frac{\theta}{2}\right) \cos\left(\frac{\theta}{2}\right)$
- $\frac{d\sigma}{d\Omega}(\theta) 2\pi \sin(\theta) d\theta = -2\pi b \cdot db$  (2 slides before)

Point like electron on a point like nucleus with infinite mass. Spin-less electron & nucleus

$$\left(\frac{d\sigma}{d\Omega}\right)_{Rutherford} = \left(\frac{zZe^2 m}{4\pi\epsilon_0}\right)^2 \frac{1}{4p^4 \sin^4\left(\frac{\theta}{2}\right)} = \left(\frac{zZe^2 m}{4\pi\epsilon_0}\right)^2 \frac{4}{(\Delta p)^4}$$



# Rutherford scattering - continued

Look at Lecture Notes!!

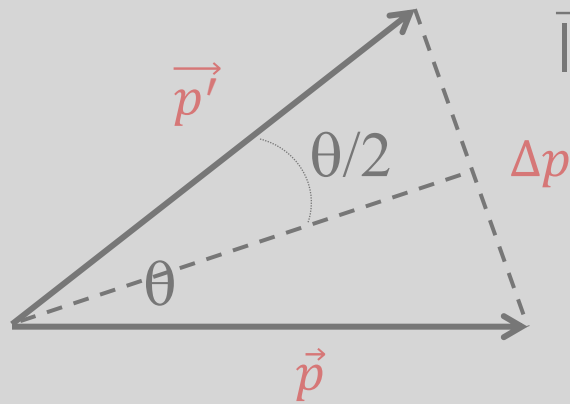

$$|\vec{p}'| = |\vec{p}|; \Delta p = |\vec{p}' - \vec{p}| = 2 p \sin\left(\frac{\theta}{2}\right)$$

$$\tan(\theta/2) = \frac{\text{Classical Relation Potential energy at a distance } 2b}{\text{Kinetic energy}} = \frac{zZe^2}{2bE_c}$$

$$\rightarrow b = \frac{zZe^2 \cot(\theta/2)}{2E_c}$$

$E_c$  = kinetic energy of  $\alpha$  particle,

And using

- $d(\cot x) = -(\sin x)^2 dx$
- $\frac{d\sigma}{d\Omega}(\theta) 2\pi \sin(\theta) d\theta = -2\pi b \cdot db$  (2 slides before)

# NEGLECT

$$\frac{db}{d\theta} = \frac{zZe^2}{2 \cdot 4 b E_c \sin(\theta/2)^2}$$

We get

$$\frac{d\sigma}{d\Omega}(\theta) = -\frac{b}{\sin\theta} \frac{db}{d\theta} = \frac{(zZe^2)^2}{(4 E_c)^2 \sin(\theta/2)^4}$$

← Valid for a spinless particle



# Targets with Extended Charge Distribution

We treated a simple case, nucleus is point-like ( $\rightarrow$  low energy particles)

Let's consider the case of Extended Charge Distribution  
 $\rightarrow$  the probe (=the electron) sees the internal structure

The nucleus is NOT point-like

- an electron beam with a density  $n_a$  particles per unit volume,
- scattering on a very heavy nucleus  $\rightarrow$  recoil is so small that  $\sim 0$ .
- If target charge  $Ze$  is  $\sim$  small  $\rightarrow$  the electro-magnetic interaction will be small  $Z\alpha \ll 1$  ( $\alpha=1/137$ ).
- In this case the wave functions  $\Psi_i$  and  $\Psi_f$  of the initial and final state (i.e. electron) will be described by plane waves:

$$\Psi_i = \frac{1}{\sqrt{V}} e^{ipx/\hbar} \quad \Psi_f = \frac{1}{\sqrt{V}} e^{ip'x/\hbar}$$

We assume that the process takes place in a volume  $V$  (large with respect to the scattering centre) and that wave functions of the incoming and outgoing electrons are normalised in this volume. We have a total number of  $N_a$  electrons in the beam

$$\int_V |\psi_i|^2 dV = n_a \cdot V \quad \text{where} \quad V = \frac{N_a}{n_a}$$





# Extended Charge Distribution

1) Scattering reaction rate:

$$W = \frac{\sigma v_a}{V}$$

2) We apply Fermi's Golden Rule:

$$W = \frac{2\pi}{\hbar} |M_{fi}|^2 \rho(E') = \frac{2\pi}{\hbar} |\langle \psi_f | \mathcal{H}_{int} | \psi_i \rangle|^2 \frac{dn}{dE_f}$$

3) Density of final states:

$$dn(p') = V 4\pi p'^2 dp' / (2\pi\hbar)^3$$

$E_f$  is the total energy of the final state

If we combine 1, 2, 3

$$d\sigma \cdot v_a \cdot \frac{1}{V} = \frac{2\pi}{\hbar} |\langle \psi_f | \mathcal{H}_{int} | \psi_i \rangle|^2 \frac{V |\mathbf{p}'|^2 d|\mathbf{p}'|}{(2\pi\hbar)^3 dE_f} d\Omega$$

The beam particle velocity  $v_a \sim c$  and  $|\mathbf{p}'| \sim E'/c \rightarrow$

$\frac{d\sigma}{d\Omega} = \frac{V^2 E'^2}{(2\pi)^2 (\hbar c)^4}  \langle \psi_f   \mathcal{H}_{int}   \psi_i \rangle ^2$
Kinematics      Physics



# Some Calculation...

The interaction operator that transforms the initial state into a final one for a charge  $e$  in an electric potential  $\phi$  is:

$$\mathcal{H}_{int} = e\phi(x)$$

And the matrix element  $\langle \psi_f | \mathcal{H}_{int} | \psi_i \rangle$  becomes

$\phi \rightarrow \phi(x)$ , diffused charge, not point-like

$$\langle \psi_f | \mathcal{H}_{int} | \psi_i \rangle = \frac{e}{V} \int e^{-\frac{i\mathbf{p}' \cdot \mathbf{x}}{\hbar}} \phi(x) e^{\frac{i\mathbf{p} \cdot \mathbf{x}}{\hbar}} d^3x$$

The momentum transfer between  $\mathbf{p}$  and  $\mathbf{p}'$  is defined as  $\mathbf{q} = \mathbf{p} - \mathbf{p}' \rightarrow$

$$\langle \psi_f | \mathcal{H}_{int} | \psi_i \rangle = \frac{e}{V} \int \phi(x) e^{\frac{i\mathbf{q} \cdot \mathbf{x}}{\hbar}} d^3x$$

And with some calculation (Green's theorem & Poisson's equation, see next slide)

$$\langle \psi_f | \mathcal{H}_{int} | \psi_i \rangle = \frac{e\hbar^2}{\epsilon_0 V |\mathbf{q}^2|} \int f(x) e^{\frac{i\mathbf{q} \cdot \mathbf{x}}{\hbar}} d^3x = \frac{e\hbar^2}{\epsilon_0 V |\mathbf{q}^2|} F(\mathbf{q})$$

Where we have defined  $F(\mathbf{q}) = \int f(x) e^{\frac{i\mathbf{q} \cdot \mathbf{x}}{\hbar}} d^3x$ , called form factor of the charge distribution.

The form factor describes the charge distribution of the target we are studying in our scattering experiment.



# Green's Theorem

■ Green's theorem permits us to use a clever trick here: for two arbitrarily chosen scalar fields  $u$  and  $v$ , which fall off fast enough at large distances, the following equation holds for a sufficiently large integration volume:

$$\int (u\Delta v - v\Delta u) d^3x = 0, \quad \text{with } \Delta = \nabla^2. \quad (5.27)$$

Inserting:

$$e^{i\mathbf{q}\mathbf{x}/\hbar} = \frac{-\hbar^2}{|\mathbf{q}|^2} \cdot \Delta e^{i\mathbf{q}\mathbf{x}/\hbar} \quad (5.28)$$

into (5.26), we may rewrite the matrix element as:

$$\langle \psi_f | \mathcal{H}_{\text{int}} | \psi_i \rangle = \frac{-e\hbar^2}{V|\mathbf{q}|^2} \int \Delta\phi(\mathbf{x}) e^{i\mathbf{q}\mathbf{x}/\hbar} d^3x. \quad (5.29)$$

The potential  $\phi(\mathbf{x})$  and the charge density  $\rho(\mathbf{x})$  are related by Poisson's equation:

$$\Delta\phi(\mathbf{x}) = \frac{-\rho(\mathbf{x})}{\epsilon_0}. \quad (5.30)$$

In the following, we will assume the charge density  $\rho(\mathbf{x})$  to be static, i. e. independent of time.

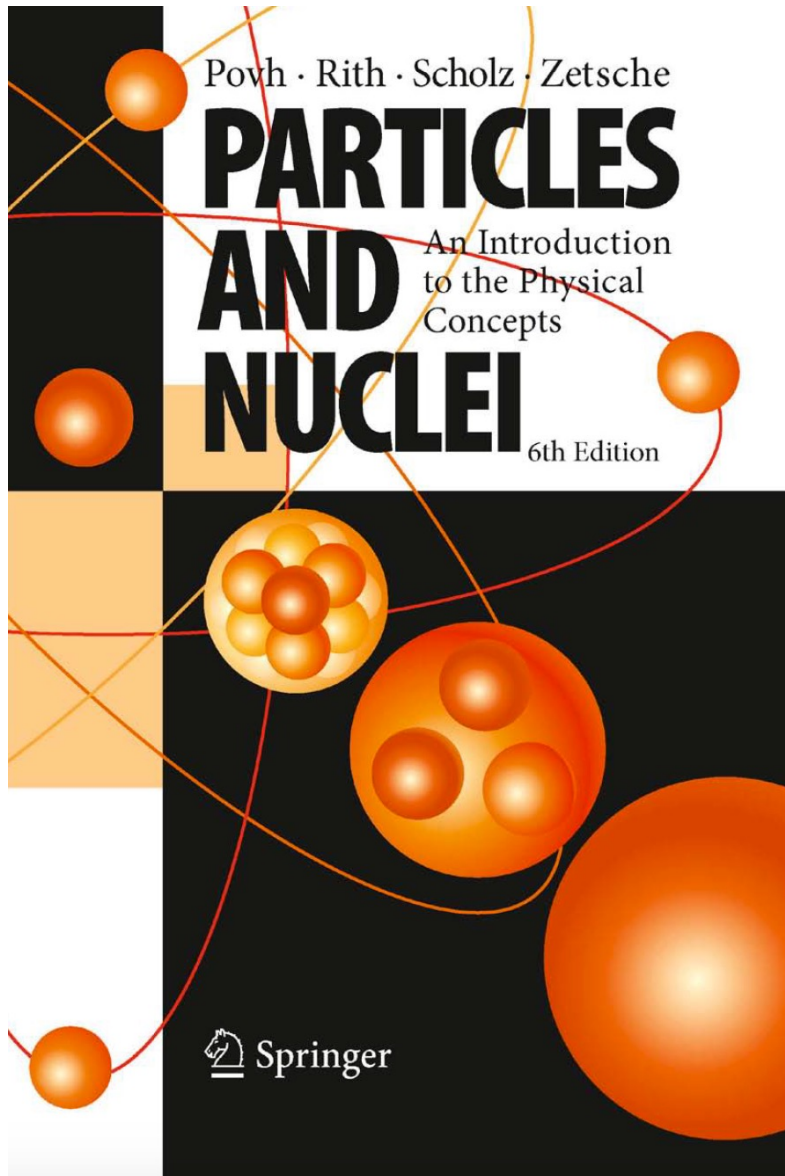



# Getting the point-like Rutherford Cross Section

$\epsilon_0$  is the permittivity of free space

$$\langle \psi_f | \mathcal{H}_{int} | \psi_i \rangle = \frac{e\hbar^2}{\epsilon_0 V |\mathbf{q}^2|} \int f(x) e^{\frac{i\mathbf{q}x}{\hbar}} d^3x = \frac{e\hbar^2}{\epsilon_0 V |\mathbf{q}^2|} F(\mathbf{q})$$

If we neglect the fact that our target has an extended charge distribution then  $F(\mathbf{q})$  becomes a  $\delta$  function  $\rightarrow F(\mathbf{q}) = 1$ . If we do this approximation then we get Rutherford cross section in the case of a point-like charge distribution and expressed as a function of the momentum transfer  $\mathbf{q}$ .

$$d\sigma/d\Omega = \frac{4Z^2\alpha^2(\hbar c)^2 E'^2}{|\mathbf{q}c|^4}$$

$$\alpha_{EM} = \frac{e^2}{4\pi\epsilon_0\hbar c}$$

The  $1/q^4$  dependence indicates that the cross section drops very quickly for large values of  $\mathbf{q}$  and that the largest part of the cross section is limited to small values of  $\mathbf{q}$ .

Let's remember that

- If we neglect recoil  $E=E'$
- $|\mathbf{p}| = |\mathbf{p}'|$
- $E=|\mathbf{p}|c$  is a good approximation

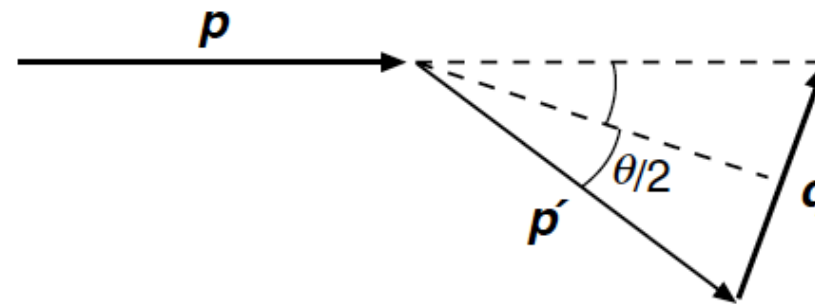

$$|\mathbf{q}| = 2 \cdot |\mathbf{p}| \sin \frac{\theta}{2}$$

We get the classical expression for a point-like target

$$\left( \frac{d\sigma}{d\Omega} \right)_{\text{Rutherford}} = \frac{Z^2\alpha^2(\hbar c)^2}{4E^2 \sin^4 \frac{\theta}{2}}$$



# Understanding $F(q^2)$

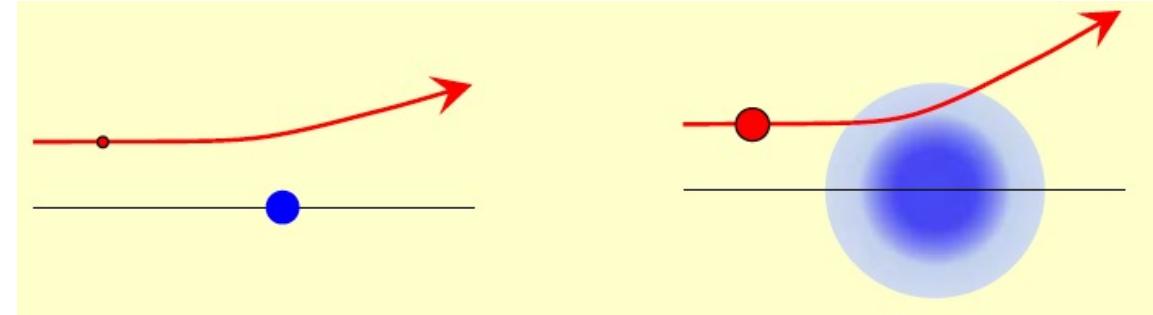
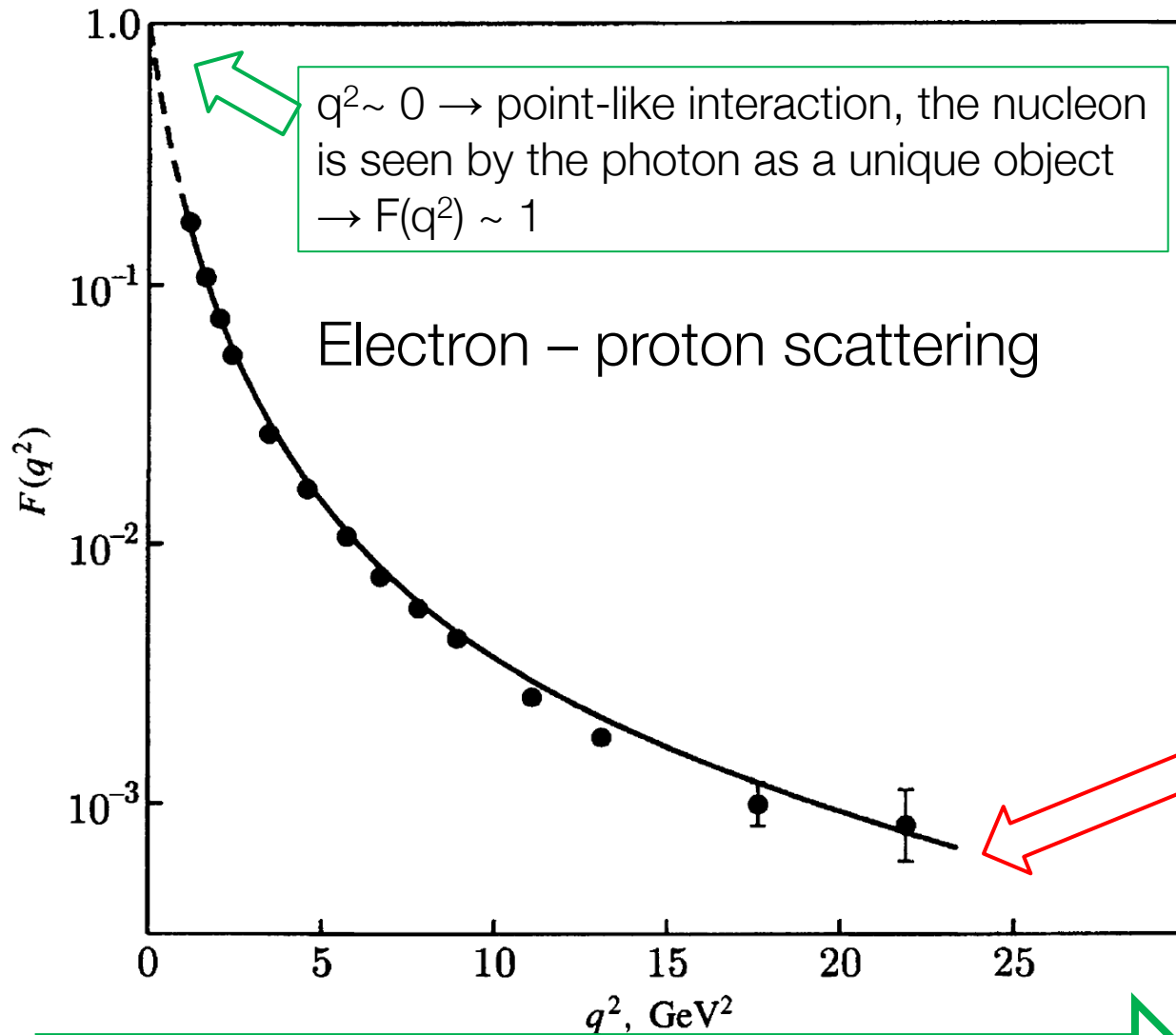

$F(q^2)$  indicates how well the nucleon 'holds together' (= is not 'broken') if hit by a photon of momentum  $q^2$

$q^2 \sim$  large  $\rightarrow$  diffused charge  $\rightarrow$  the photon sees only a part of the charge of the nucleon  $\rightarrow F(q^2) \sim$  very low

When  $q^2$  increases  $\rightarrow$  the probe becomes very small



# Changing Point of View: Field Theory

The scattering of an electron on a target with charge  $Ze$  is mediated by the exchange of a virtual photon emitted by the electron and absorbed by the target (see picture here  $\rightarrow$ ).

The transition matrix  $\sim e \cdot Ze$  and the cross section  $\sim (e \cdot Ze)^2$ .

*The momentum transfer  $q$  is the momentum carried by the photon and transferred from the electron to the target.*

The equivalent de-Broglie wave-length of the photon is

$$\lambda = \frac{\hbar}{q} = \frac{\hbar}{|\mathbf{p}|} \frac{1}{2\sin\frac{\vartheta}{2}}$$

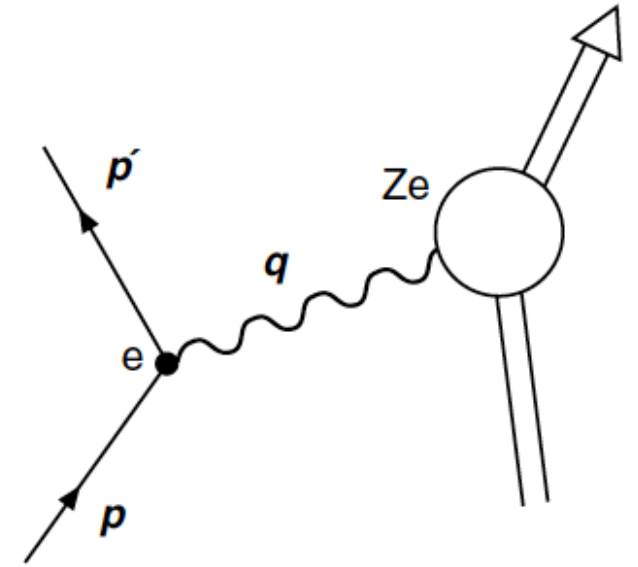

- *if the de-Broglie wave-length of the photon is NOT small enough with respect to the extension of the target it cannot probe the internal structure of the scattering centres and the target appears to be point-like.*
  - *The Rutherford cross section was obtained with low energy electrons corresponds to this situation.*

The propagator in the matrix element  $\frac{1}{Q^2 + M^2 c^2}$  becomes simply  $\frac{1}{Q^2}$



# Rutherford Scattering

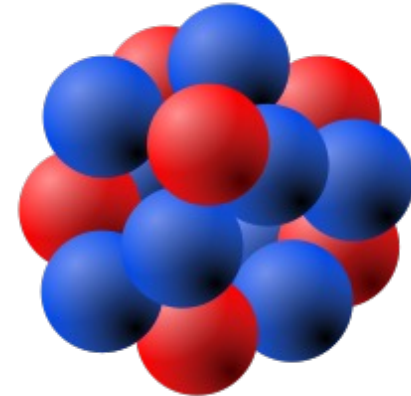
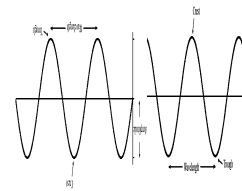
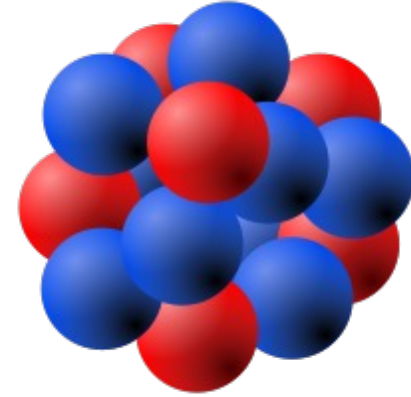
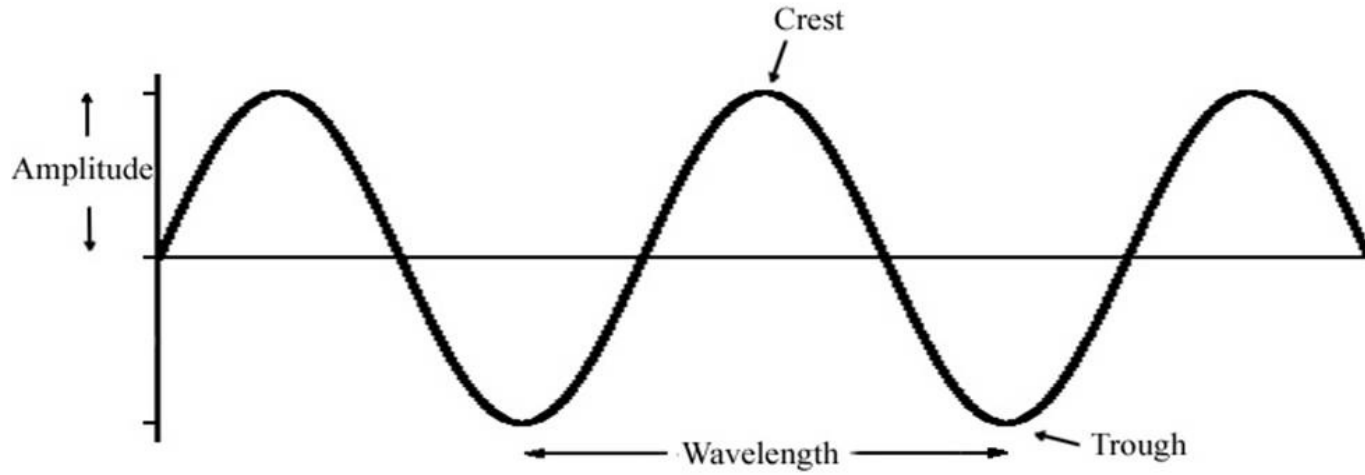



# Scattering of electrons on nucleus/proton

Calculation	electron		Target, charge Ze (Z=1 proton)					Expression
	electron	Electron with spin	Point-like target, infinite Mass	Point-like target with mass M	Point-like proton	Point-like proton with spin	Finite size proton with spin	
Rutherford	✓		✓					$\left(\frac{d\sigma}{d\Omega}\right)_R = \frac{Z^2 e^4}{4E_0^2 (\sin \theta/2)^4}$
Mott		✓		✓				$\left(\frac{d\sigma}{d\Omega}\right)_M = \left(\frac{d\sigma}{d\Omega}\right)_R \cdot (\cos \frac{\theta}{2})^2$
$\sigma_{NS}$		✓			✓			$\left(\frac{d\sigma}{d\Omega}\right)_{NS} = \left(\frac{d\sigma}{d\Omega}\right)_M \cdot 1 / \left(1 - \frac{2E_0}{M} \sin \theta/2^2\right)$
$\sigma$		✓				✓		$\left(\frac{d\sigma}{d\Omega}\right) = \left(\frac{d\sigma}{d\Omega}\right)_M \cdot \left(1 + \frac{q^2}{2M^2} \tan \theta/2^2\right)$
Rosenbluth		✓					✓	$\left(\frac{d\sigma}{d\Omega}\right) = \left(\frac{d\sigma}{d\Omega}\right)_M \cdot \left[ \frac{G_E^2(Q^2) + \tau \cdot G_M^2(Q^2)}{1 + \tau} + 2\tau G_M^2(Q^2) \tan \theta/2^2 \right]$







# Electron Spin → The Mott Cross Section (point-like objects)

The Rutherford cross section neglects the spin of the electron

The electron spin modifies the Rutherford cross section introducing a term  $(1 - \beta^2 \sin^2 \frac{\theta}{2})$ ,  $\beta = v/c$

$$(d\sigma/d\Omega)_{Mott} = (d\sigma/d\Omega)_{Rutherford} \cdot (1 - \beta^2 \sin^2 \frac{\theta}{2})$$

Large scattering angles are suppressed

In the limit case  $\beta \rightarrow 1$  we get:  $(d\sigma/d\Omega)_{Mott} = (d\sigma/d\Omega)_{Rutherford} \cdot (\cos^2 \frac{\theta}{2})$   
 → for a scattering angle of  $180^\circ$  we have a zero cross-section

This is understood with the conservation of helicity, the projection of the spin in the direction of the motion :  $h = \mathbf{s} \cdot \mathbf{p} / (|\mathbf{s}| \cdot |\mathbf{p}|)$

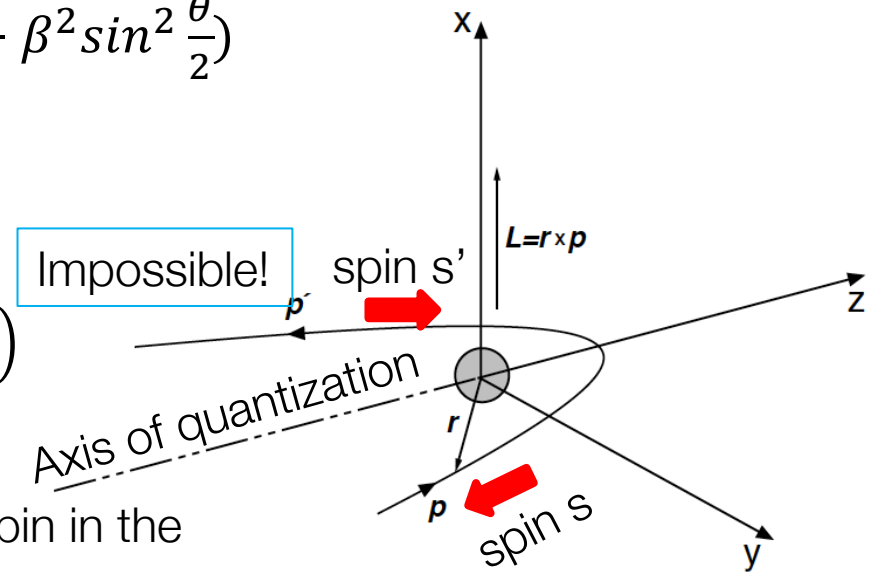

Neither the orbital angular momentum  $\mathbf{L}$  (pointing up with respect to the plane of motion) nor the spin-less target can compensate the flip of the helicity. The situation changes in case of a target with spin.



# Nuclear Form Factors

- The Rutherford Cross Section represents well data only for small  $q$ .
- For higher values of  $q$  data are lower than predicted by the Rutherford formula
- This is understood with the fact that *assuming that the charge distribution  $F(q)$  of a nucleus is point-like* is acceptable only when  $q$  is small  $\rightarrow$  the reduced wave length of the photon is too large to probe the charge distribution of the nucleus.
- In this picture ( $q$  small) the photon sees the nucleus (or the nucleon) as a unique object.
- When  $q$  increases the photon starts to see the inner structure of the proton  $\rightarrow$  the photon starts to see only a part of the charge and not all of it
- $\rightarrow$  the cross section decreases with  $q$  faster than expected.

- The form factor,  $F(q^2)$ , carrying the information on how the charge is distributed inside the nucleus  $f(x) \sim$  modulates the Mott cross section

$$F(q^2) = \int e^{\frac{iqx}{\hbar}} f(x) d^3x \quad \left(\frac{d\sigma}{d\Omega}\right)_{exp.} = \left(\frac{d\sigma}{d\Omega}\right)_{Mott} \cdot |F(q^2)|^2$$

- The ratio between measurements and the Mott cross section for a point-like charge distribution allows the measurement of the charge distribution inside the nucleus.
- You measure the angle of the scattered electron, you compute  $q$ , you do the ratio.



# More on Form Factors (Povh)

One could measure the ratio

$$|F(q^2)|^2 = \left(\frac{d\sigma}{d\Omega}\right)_{exp.} / \left(\frac{d\sigma}{d\Omega}\right)_{Mott}$$

But in practice one assumes different analytical shapes and compares data with predictions

Charge distribution $f(r)$		Form Factor $F(q^2)$	
point	$\delta(r)/4\pi$	1	constant
exponential	$(a^3/8\pi) \cdot \exp(-ar)$	$(1 + q^2/a^2\hbar^2)^{-2}$	dipole
Gaussian	$(a^2/2\pi)^{3/2} \cdot \exp(-a^2r^2/2)$	$\exp(-q^2/2a^2\hbar^2)$	Gaussian
homogeneous sphere	$\begin{cases} 3/4\pi R^3 & \text{for } r \leq R \\ 0 & \text{for } r > R \end{cases}$	$3\alpha^{-3}(\sin\alpha - \alpha\cos\alpha)$ with $\alpha =  q R/\hbar$	oscillating

$$f(x) \quad F(q^2) = \int e^{\frac{iqx}{\hbar}} f(x) d^3x$$

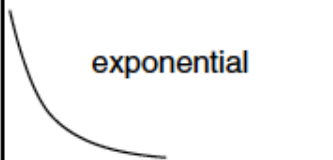
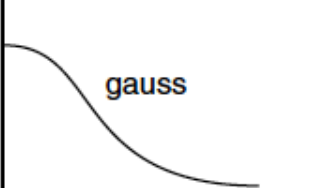
		Example
pointlike	constant	Electron
	dipole	Proton
	gauss	${}^6\text{Li}$
homogeneous sphere	oscillating	-
sphere with a diffuse surface	oscillating	${}^{40}\text{Ca}$

$r \rightarrow$                        $|q| \rightarrow$



# Measuring the Charge Distribution of Nuclei

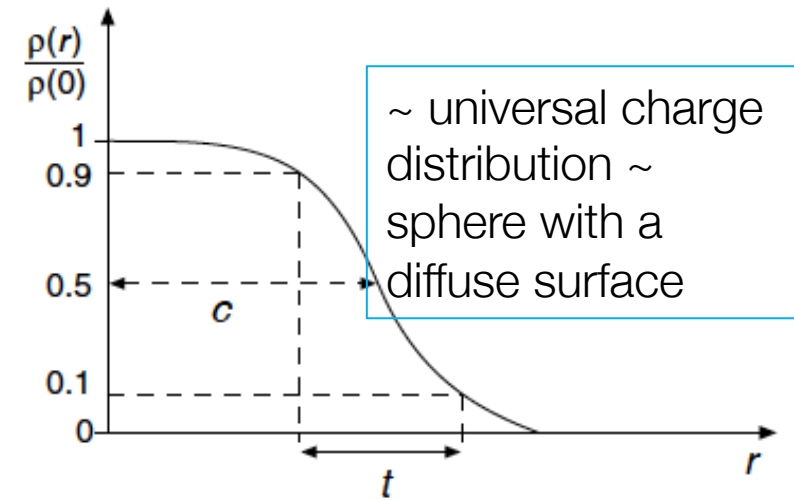
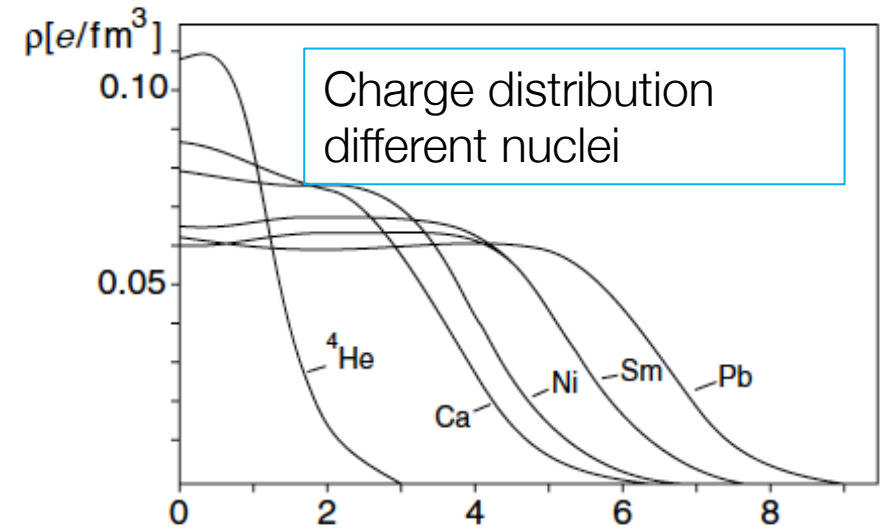
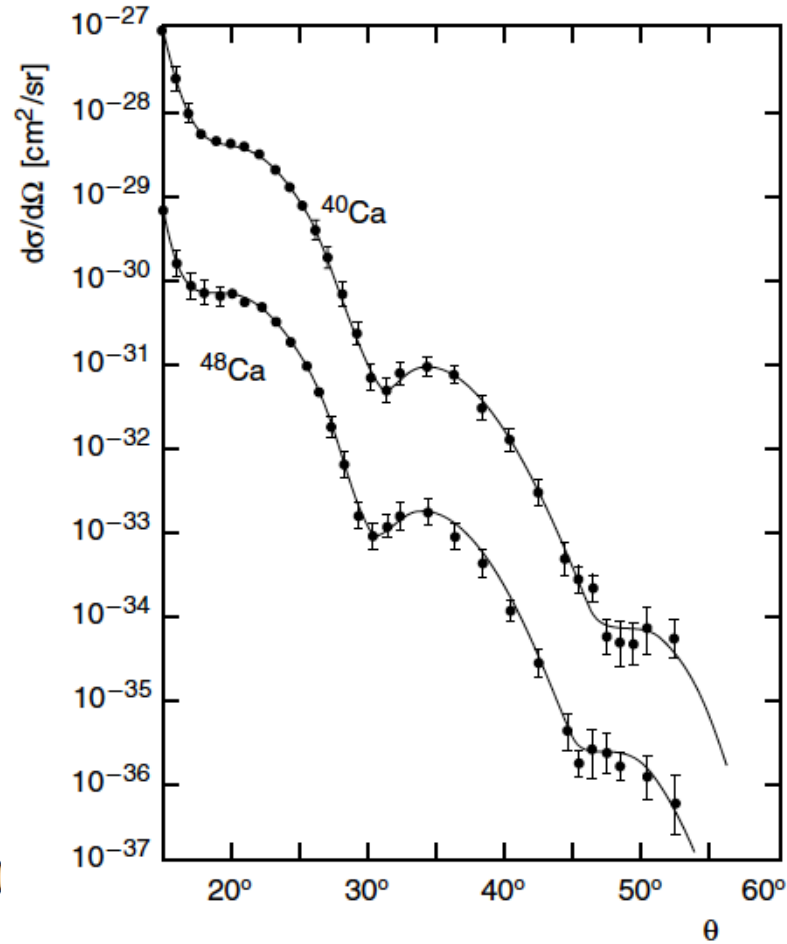
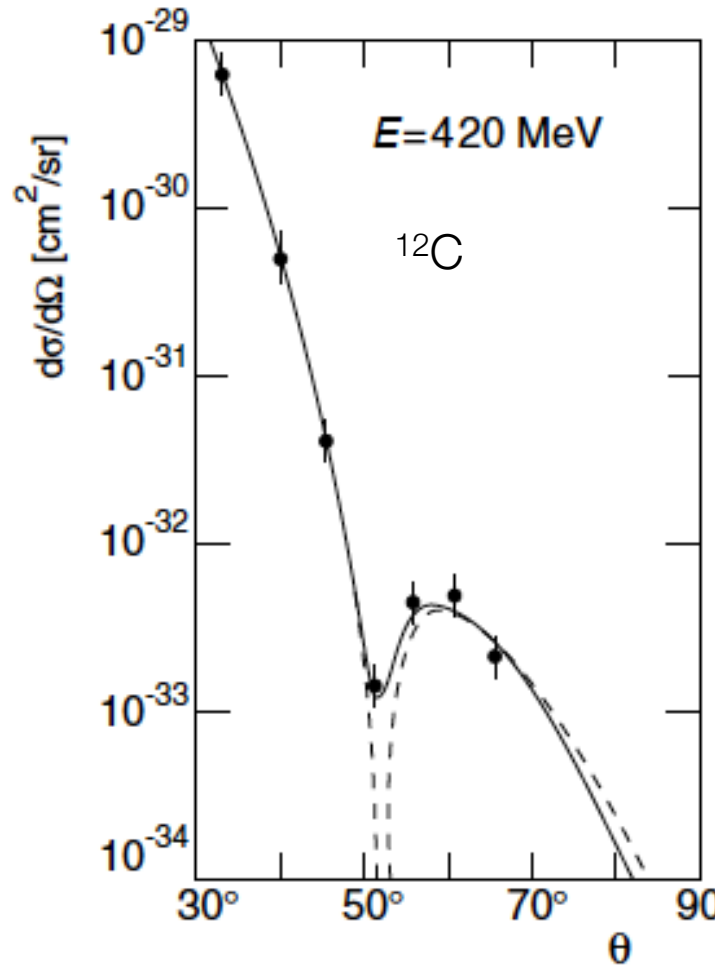



# Magnetic Moments of Charged Spin 1/2 Particles

Additional effect: interaction between the current of the electron and the nucleon's magnetic moment.

- The magnetic moment of a charged, spin 1/2 point-like particle (a Dirac particle) is:

$$\mu = g \cdot \frac{e}{2M} \cdot \frac{\hbar}{2}$$

- $M$  is the mass of the particle and the  $g = 2$  factor is a result of relativistic quantum mechanics;
- The magnetic interaction is associated with a flip of the spin of the nucleon.*
- Scattering through  $0^\circ$  is not allowed: conservation of both angular momentum and helicity and scattering through  $180^\circ$  is preferred. The magnetic interaction thus introduces into the interaction an **additional** factor containing a factor of  $\tan^2 \theta/2$  and due to the interaction of the magnetic interaction proton/electron:

Interaction with charge of target

Interaction with magnetic moment of target

$$\left(\frac{d\sigma}{d\Omega}\right)_{point\ spin\ \frac{1}{2}} = \left(\frac{d\sigma}{d\Omega}\right)_{Mott} \left[ 1 + 2\tau \tan^2 \frac{\theta}{2} \right]$$

$$\text{where } \tau = \frac{Q^2}{M^2 c^2}$$



# Magnetic Moments of Charged Spin $\frac{1}{2}$ Particles

$$\left(\frac{d\sigma}{d\Omega}\right)_{point\ spin\ \frac{1}{2}} = \left(\frac{d\sigma}{d\Omega}\right)_{Mott} \left[1 + 2\tau \tan^2 \frac{\theta}{2}\right] \quad \text{where } \tau = \frac{Q^2}{M^2 c^2}$$

- The interaction with magnetic moment of target is proportional to  $1/(M^2)$ , to the deflection of the electron (i.e., to the momentum transfer  $Q^2$ ).
- The magnetic term in the expression is large at high four-momentum transfers  $Q^2$  and if the scattering angle  $\theta$  is large.

This additional term causes the cross section to fall off *less strongly at larger angles*  $\rightarrow$  at large values of  $Q^2$  a flatter distribution is found than what predicted by the electric interaction.

The g-factor of a spin  $\frac{1}{2}$  charged particle is exactly 2 (but for small understood very small deviations) while the g-factor of a spin  $\frac{1}{2}$  neutral particle is exactly 0.

**HOWEVER** Nucleons are made up of quarks and this changes things  
Their g-factors for protons and neutrons are determined by the internal structure

Measured!

$$\mu_p = \frac{g_p}{2} \mu_N = +2.79 \cdot \mu_N ,$$

$$\mu_n = \frac{g_n}{2} \mu_N = -1.91 \cdot \mu_N ,$$

Where  $\mu_N$  is

$$\mu_N = \frac{e\hbar}{2M_p} = 3.1525 \cdot 10^{-14} \text{ MeV T}^{-1}$$



# Magnetic Moments of the Proton and Neutron

Nuclei  $\leftrightarrow$  form factors ((nucleus has a structure))

Nucleons (with internal structure)  $\leftrightarrow$  form factors to describe electric  $G_E(Q^2)$  and magnetic  $G_M(Q^2)$  interactions (nucleon has a structure)

$$\left(\frac{d\sigma}{d\Omega}\right) = \left(\frac{d\sigma}{d\Omega}\right)_{Mott} \cdot \left[ \frac{G_E^2(Q^2) + \tau \cdot G_M^2(Q^2)}{1 + \tau} + 2\tau G_M^2(Q^2) \tan^2 \frac{\theta^2}{2} \right] \text{ where } \tau = \frac{Q^2}{M^2 c^2}$$

$Q^2$  dependence of the form factors  $\leftrightarrow$  the radial charge distributions and the magnetic moments.

- At low  $Q^2$   $\left(\frac{d\sigma}{d\Omega}\right) / \left(\frac{d\sigma}{d\Omega}\right)_{Mott} \approx G_E^2(Q^2)$
- At high  $Q^2$   $\left(\frac{d\sigma}{d\Omega}\right) / \left(\frac{d\sigma}{d\Omega}\right)_{Mott} \approx G_M^2(Q^2) (1 + 2\tau \tan^2 \frac{\theta^2}{2})$

$\rightarrow$  Vary electron beam energy  $\rightarrow$  vary  $Q^2$

$\rightarrow$  measure electron scattering angle  $\rightarrow \tan^2 \frac{\theta^2}{2}$

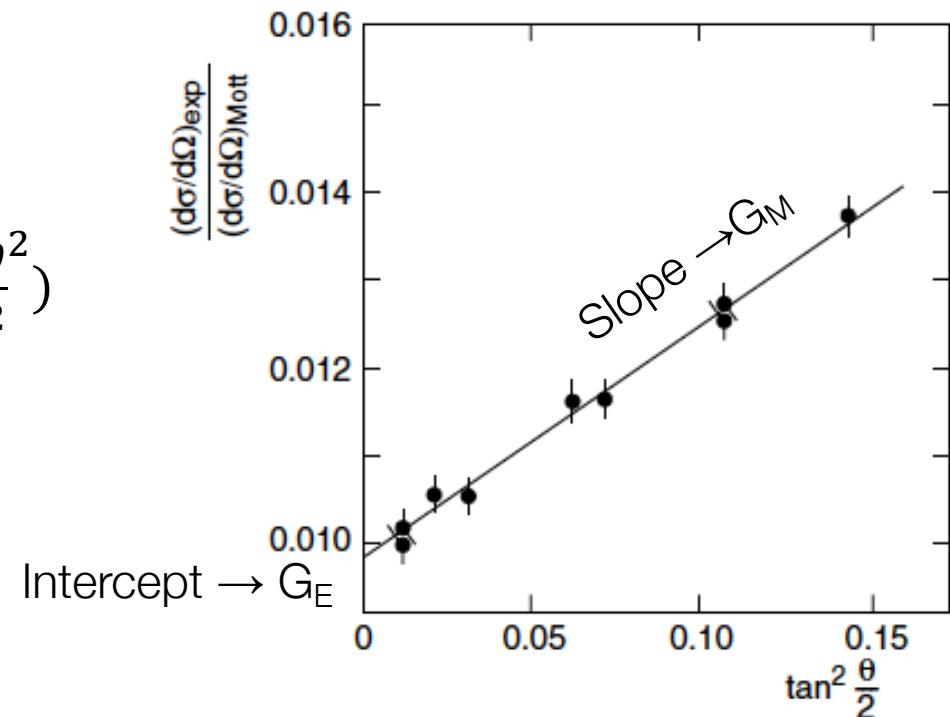



# *Introductory Part*

*Particle Physics*  
*Toni Baroncelli*  
*Haiping Peng*  
*USTC*

*End of Introductory Part*





# Conservation Laws (~Invariance): Parity

- Invariance properties applies to physical systems described by an equation. The system is considered as invariant if the equation describing it is invariant under given transformations (say rotation or translation)
- Invariance properties are closely connected to conservation laws.

*Transformations can be either continuous or discrete.*

Symmetries are of great importance in physics. The conservation laws of classical physics (energy, momentum, angular momentum) are a consequence of the fact that the interactions are invariant with respect to their canonically conjugate quantities (time, space, angles). In other words, physical laws are independent of the time, the location and the orientation in space under which they take

## Parity

**Parity (P)** is a reflection symmetry: depending on whether the sign of the wave function changes under reflection or not, the system is said to have negative or positive **P** respectively. For those laws of nature with left-right symmetry, the parity quantum number **P** of the system is conserved.

inverts the coordinates

does not change time

as a consequence

it inverts momenta

and does not change angular momenta

including spins

$$\mathbf{r} \Rightarrow -\mathbf{r}$$

$$t \Rightarrow t$$

$$\mathbf{p} \Rightarrow -\mathbf{p}$$

$$\mathbf{r} \times \mathbf{p} \Rightarrow \mathbf{r} \times \mathbf{p}$$

$$\mathbf{s} \Rightarrow \mathbf{s}.$$



# Symmetries in Particle Physics: Parity

One has to ascribe an intrinsic parity  $\mathbb{P}$  to particles and antiparticles.

- Bosons and anti-bosons have the same intrinsic parity.
- fermions and antifermions have opposite parities.
- For a many-body system,  **$\mathbb{P}$  is a multiplicative quantum number** :

$$\mathbb{P}\psi(\vec{x}_1, \vec{x}_2 \dots \vec{x}_n, t) = P_1 P_2 \dots P_n \psi(\vec{x}_1, \vec{x}_2 \dots \vec{x}_n, t).$$

- Particles in a state of orbital angular momentum are parity eigenstates :

$$Y_{km}(\theta, \phi) = (-1)^k Y_{km}(\pi - \theta, \phi + \pi) \rightarrow \mathbb{P} |\psi_{km}(\theta, \phi)\rangle = (-1)^k |\psi_{km}(\theta, \phi)\rangle$$

- Therefore, for a two or a three particle system:

$$P_{\text{sys}(12)} = P_1 P_2 (-1)^L ;$$

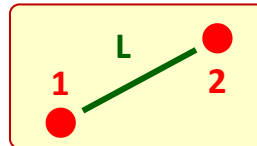

$$P_{\text{sys}(123)} = P_1 P_2 P_3 (-1)^{L_1 + L_2}$$

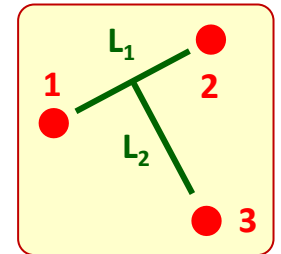

It is an experimental fact that parity is conserved in all transitions due to electromagnetic and strong interactions. Parity is instead violated in weak interaction transitions



# Wave function for two identical particles

The concept of parity has been generalised in relativistic quantum mechanics. One has to ascribe an intrinsic parity  $\mathbf{P}$  to particles and antiparticles.

Take a system with *two identical particles* and define an operator  $I$  that exchanges the two particles

$$I(1,2) \rightarrow (2,1)$$

The corresponding wave function will not change

$$I\Psi(1,2) = \Psi(2,1)$$

If we apply “I” twice we go back to the initial situation

$$I^2\Psi(1,2) = \Psi(1,2) \rightarrow \text{possible eigenvalues of } I \text{ are } \pm 1$$

It is assumed that

- Bosons and antibosons have integer spin (follow the Bose-Einstein statistics) and the same intrinsic parity.  $\Psi(1,2) = \Psi(2,1)$  **are symmetric**
- Fermions and antifermions have half integer spin and opposite parities.  $\Psi(1,2) = -\Psi(2,1)$  **anti-symmetric**

- Convention: P(quarks/leptons) =  
+1 =  $P_{e^-} = P_{\mu^-} = P_{\tau^-} = P_u = P_d = P_s = \dots$ ;  
-1 =  $P_{e^+} = P_{\mu^+} = P_{\tau^+} = P_{\bar{u}} = P_{\bar{d}} = P_{\bar{s}} = \dots$



# Getting the Breit Wigner Shape

Let us imagine the elastic formation process of a generic resonance R, which decays with lifetime  $\tau$  into the same initial particles. The presence of a interaction process is demonstrated by the different directions and momenta of the particles in the final state, that is,

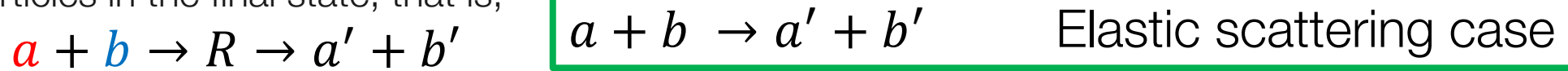

The unstable resonance R is described by the free particle wave function  $\psi(0)e^{-i\omega_R t}$  multiplied by a real function describing its decay probability as a function of time, that is,

$$\psi(t) = \boxed{\psi(0)e^{-i\omega_R t}} \boxed{e^{-\frac{t}{\tau}}} = \psi(0)e^{-\frac{iE_R}{\hbar}t} e^{-\frac{\Gamma}{2\hbar}t},$$

where the relations  $\omega_R = \frac{E_R}{\hbar}$  and  $\tau = \frac{\hbar}{\Gamma}$  have been inserted in the last equality. The probability of finding the particle at a time t is

$$I(t) = \psi^* \psi = \psi(0)^2 e^{-t/\tau} = I(0) \boxed{e^{-t/\tau}}, \quad \text{Exponential life-time}$$

corresponding to the radioactive decay law.

The Fourier transform is a transformation that decomposes functions depending on space or time into functions depending on spatial or temporal frequency  $\rightarrow$  gives us the energy distribution

$$\chi(E) = \int \psi(t)e^{iEt} dt = \psi(0) \int e^{-t[(\Gamma/2)+iE_R-iE]} dt = \int_0^\infty e^{-ax} dx = \frac{1}{a} = \frac{\boxed{K \ ?}}{(E_R - E) - i\Gamma/2}$$



# The Transition Matrix Element

The cross-section can be experimentally determined from the reaction rate  $\dot{N}$ , as we saw above. We now outline how it may be found from theory. First, the reaction rate is dependent upon the properties of the interaction potential described by the Hamilton operator  $\mathcal{H}_{\text{int}}$ . In a reaction, this potential transforms the initial-state wave function  $\psi_i$  into the final-state wave function  $\psi_f$ . The transition matrix element is given by:

$$\mathcal{M}_{fi} = \langle \psi_f | \mathcal{H}_{\text{int}} | \psi_i \rangle = \int \psi_f^* \mathcal{H}_{\text{int}} \psi_i \, dV .$$

Furthermore, the reaction rate will depend upon the number of final states available to the reaction. According to the uncertainty principle, each particle occupies a volume  $h^3 = (2\pi)^3$  in phase space, the six-dimensional space of momentum and position. Consider a particle scattered into a volume  $V$  and into a momentum interval between  $p$  and  $p + dp$ . In momentum space, the interval corresponds to a spherical shell with inner radius  $p$  and thickness  $dp$  which has a volume  $4\pi p^2 dp$ . Excluding processes where the spin changes, the number of final states available is:

$$dn(p') = \frac{V \cdot 4\pi p'^2}{(2\pi\hbar)^3} dp' .$$



# The Transition Matrix Element

The energy and momentum of a particle are connected by:

$$dE' = v' dp'.$$

Hence the density of final states in the energy interval  $dE$  is given by:

$$\rho(E') = \frac{dn(E')}{dE'} = \frac{V \cdot 4\pi p'^2}{v' \cdot (2\pi\hbar)^3}.$$

The connection between the reaction rate, the transition matrix element and the density of final states is expressed by Fermi's second golden rule (not discussed here). It expresses the reaction rate  $W$  per target particle and per beam particle in the form:

$$W = \frac{2\pi}{\hbar} |\mathcal{M}_{fi}|^2 \cdot \rho(E').$$

with cross section

$$\sigma = \frac{2\pi}{\hbar \cdot v_a} |\mathcal{M}_{fi}|^2 \cdot \rho(E') \cdot V.$$



# The Transition Matrix Element

The golden rule applies to both scattering, to the decay of unstable particles, to the excitation of particle resonances and to the transitions between different atomic or nuclear energy states. In these cases we have

$$W = \frac{1}{\tau}$$

and the transition probability per unit time can be either directly determined by measuring the lifetime  $\tau$  or indirectly read off from the energy width of the state

$$\Delta E = \hbar/\tau$$